

DOCUMENT CONTROL SHEET

	ORIGINATOR'S REF. TP 97604 U	SECURITY CLASS. Unclassified												
ORIGINATOR National Aerospace Laboratory NLR, Amsterdam, The Netherlands														
TITLE The electrical architecture of a parafoil technology demonstrator														
PRESENTED AT the 14th AIAA Aerodynamic Decelerator Systems Technology Conference and Seminar, June 3-5, 1997, San Francisco, USA														
AUTHORS P.M.N. Hollestelle	DATE 971126	pp ref 21 4												
DESCRIPTORS <table style="width: 100%; border: none;"> <tr> <td style="width: 50%;">Actuators</td> <td style="width: 50%;">Flight control</td> </tr> <tr> <td>Airborne/spaceborne computers</td> <td>Flight mechanics</td> </tr> <tr> <td>Automatic control</td> <td>Flight tests</td> </tr> <tr> <td>Automatic landing control</td> <td>Navigation and guidance</td> </tr> <tr> <td>Data acquisition</td> <td>Parafoils</td> </tr> <tr> <td>Descent trajectories</td> <td>Remote control</td> </tr> </table>			Actuators	Flight control	Airborne/spaceborne computers	Flight mechanics	Automatic control	Flight tests	Automatic landing control	Navigation and guidance	Data acquisition	Parafoils	Descent trajectories	Remote control
Actuators	Flight control													
Airborne/spaceborne computers	Flight mechanics													
Automatic control	Flight tests													
Automatic landing control	Navigation and guidance													
Data acquisition	Parafoils													
Descent trajectories	Remote control													
ABSTRACT <p>A Parafoil Technology Demonstrator (PTD) programme, conducted under the responsibility of the European Space Agency and carried out by DASA Ottobrunn, with Fokker Space as one of the subcontractors, was set up to demonstrate the feasibility to autonomously guide and control a large scale parafoil to a predefined target point and to perform a flared landing within a specified range. Another objective was to enable further investigation into the flight dynamics of parafoil systems.</p> <p>The most demanding requirement for the Parafoil Technology Demonstrator Test Vehicle (PTTV) was that it must autonomously control the parafoil in such a way that a landing accuracy can be obtained of less than one hundred meter from the pre-programmed landing point. Based upon information from various sensors an on-board computer system controlled the trailing edge deflection of the parafoil.</p> <p>Through a telemetry down-link an operator on the ground could monitor the behaviour of the PTTV and if required the operator could remotely control the system.</p> <p>Via an emergency system, controlled from the ground, the release of a backup parachute can be initiated in case the main parafoil was not functioning well.</p> <p>The development approach for this demonstrator was dominated by the requirement for a short development time and the requirement to use existing designs and systems as much as possible. Especially in this area the National Aerospace Laboratory NLR contributed by developing a significant part of the instrumentation, that was based upon well-proven systems used for flight testing of aircraft.</p> <p>This paper describes the electrical architecture of the Parafoil Technology Demonstrator, that was the responsibility of Fokker Space. Some attention is paid to the mechanical layout, the ground station and the Flight Test Programme.</p>														

NLR TECHNICAL PUBLICATION

TP 97604 U

THE ELECTRICAL ARCHITECTURE OF
A PARAFOL TECHNOLOGY DEMONSTRATOR

by

P.M.N. Hollestelle

This paper was presented at the 14th AIAA Aerodynamic Decelerator Systems Technology Conference and Seminar, June 3-5, 1997, San Francisco, USA.

Division : Electronics and Instrumentation

Prepared : PMHH/ *[Signature]* 14/1/98

Approved : RK/ *[Signature]* 20/1

Completed : 971126

Order number : 083.020/WP97 1.2.I

Typ. : PMNH/IP



Abstract

A Parafoil Technology Demonstrator (PTD) programme, conducted under the responsibility of the European Space Agency and carried out by DASA Ottobrunn, with Fokker Space as one of the subcontractors, was set up to demonstrate the feasibility to autonomously guide and control a large scale parafoil to a predefined target point and to perform a flared landing within a specified range. Another objective was to enable further investigation into the flight dynamics of parafoil systems.

The most demanding requirement for the Parafoil Technology Demonstrator Test Vehicle (PTTV) was that it must autonomously control the parafoil in such a way that a landing accuracy can be obtained of less than one hundred meter from the pre-programmed landing point. Based upon information from various sensors an on-board computer system controlled the trailing edge deflection of the parafoil.

Through a telemetry down-link an operator on the ground could monitor the behaviour of the PTTV and if required the operator could remotely control the system.

Via an emergency system, controlled from the ground, the release of a backup parachute could be initiated in case the main parafoil was not functioning well.

The development approach for this demonstrator was dominated by the requirement for a short development time and the requirement to use existing designs and systems as much as possible. Especially in this area the National Aerospace Laboratory NLR contributed by developing a significant part of the instrumentation, that was based upon well-proven systems used for flight testing of aircraft.

This paper describes the electrical architecture of the Parafoil Technology Demonstrator, that was the responsibility of Fokker Space. Some attention is paid to the mechanical layout, the ground station and the Flight Test Programme.



Contents

Introduction	5
Demonstrator requirements	6
Electrical Architecture of the PTTV	7
On Board Computer System	7
Data Acquisition System	9
Sensor Systems	10
Data Storage	11
Video System	11
Telemetry System	12
Nominal and Emergency Control System	12
Actuator System	14
Power Supply	16
Mechanical Layout	17
Alignment of equipment	18
Ground Station	18
Flight Test Programme	19
Conclusions	20
References	21

6 figures

(21 pages in total)



Introduction

Late 1994 DASA, under a contract with ESA, initiated the Parafoil Technology Demonstrator (PTD) project. Within this project the feasibility of a soft and precision landing of a large scale parafoil recovery system was to be demonstrated.

The essential parts of such a recovery mission are:

- deployment and dereefing phase
- autonomous controlled descent flight
- flare manoeuvre and landing.

All these points were subject to detailed experimental and theoretical examination in order to achieve an enhanced understanding of the occurring physical phenomena. In addition, the sensitivity of performances to environmental effects (wind turbulence, gust) and the robustness of the guidance and control algorithms as well as the achievable landing accuracy were major subjects of investigation.

Within this project basic information on the suitability of a parafoil recovery system for a reentry vehicle was to be generated, with an acceptable level of reliability and safety.

The demonstration involved several droppings of the vehicle with a dummy load from a carrier aircraft at altitudes ranging from 1.4 to 4 km and a total weight varying from 1800 kg. to 3200 kg.



Demonstrator requirements

The following main requirements had been established for the deceleration function [1]:

- Parafoil 160 m² size of rectangular platform and an aspect ratio of 3.0.
- The Wing loading ranging between 10 to 20 kg/m²
- A mid span reefing system (to be deployed in three steps).

During the operational phase (deployment, dereefing and filling, descent flight including manoeuvres) the accelerations must be less than 5 g in any axis.

Flight control must be controlled via symmetrical and asymmetrical trailing edge deflection only with maximum pull down forces of 3 kN on each side.

For the Guidance, Navigation and Control (GNC) function the following requirements [1] had been established:

- Autonomous guidance and control of the Parafoil Technology demonstrator Test Vehicle (PTTV).
- Remote control of PTTV.
- Perform mission and management functions.
- Acquisition and conditioning of the required parameters.

Electrical Architecture of the PTTV

In order to perform the GNC functions the PTTV was equipped with an instrumentation system. In order to achieve the requested development time as much as possible use is made of existing flight test instrumentation equipment. Since this equipment is rather flexible, it could be tailored to meet the requirements for this demonstrator.

The general electrical architecture of this system is shown in figure 1.

The instrumentation system is designed around a VME based on-board computer system. The task of this on-board computer system is to control the test vehicle to perform a precision landing. The computer inputs the sensor information, acquired through the data acquisition system and calculates the commands that are given to a dual actuator system in order to manoeuvre the payload to the desired landing site. To monitor the descent the gathered digital data is telemetered to a ground based data processing station for real time display. To see the behaviour of the parafoil a video camera, pointing upwards, is installed on top of the PTTV. The video signal is telemetered to a ground based monitor station.

A solid state recorder stores the measured and processed data for off-line data processing. e.g. for parameter identification.

Via a dual redundant telecommand uplink system the parafoil can be manually controlled and in case of problems an emergency sequence is initiated.

The architecture is described in more detail in Ref 2.

On Board Computer System

An NLR developed airworthiness VME based computer system is used to perform the Guidance and Navigation Function. This unit comprises a 68040 processor board, running at 25 MHz. and an IRIG-PCM Input board . The latter board is used to input the serial data stream as put out by the Data Acquisition System. Further, serial ports are available for data communication with the other equipment. A terminal port enables to enter mission related coefficients prior to the release from the aircraft.

The software package required for this application consists of two modules:

- the Basic Software Module (BSW),
- the Application Software Module (ASW), i.e. the Guidance and Navigation Module (GNC).

The Basic Software Module contains the real-time operating system, scheduler and the drivers to communicate with the peripherals. It also includes routines to convert the raw PCM input data into SI-scaled units.

Fig. 1 Electrical Architecture of the PTTV

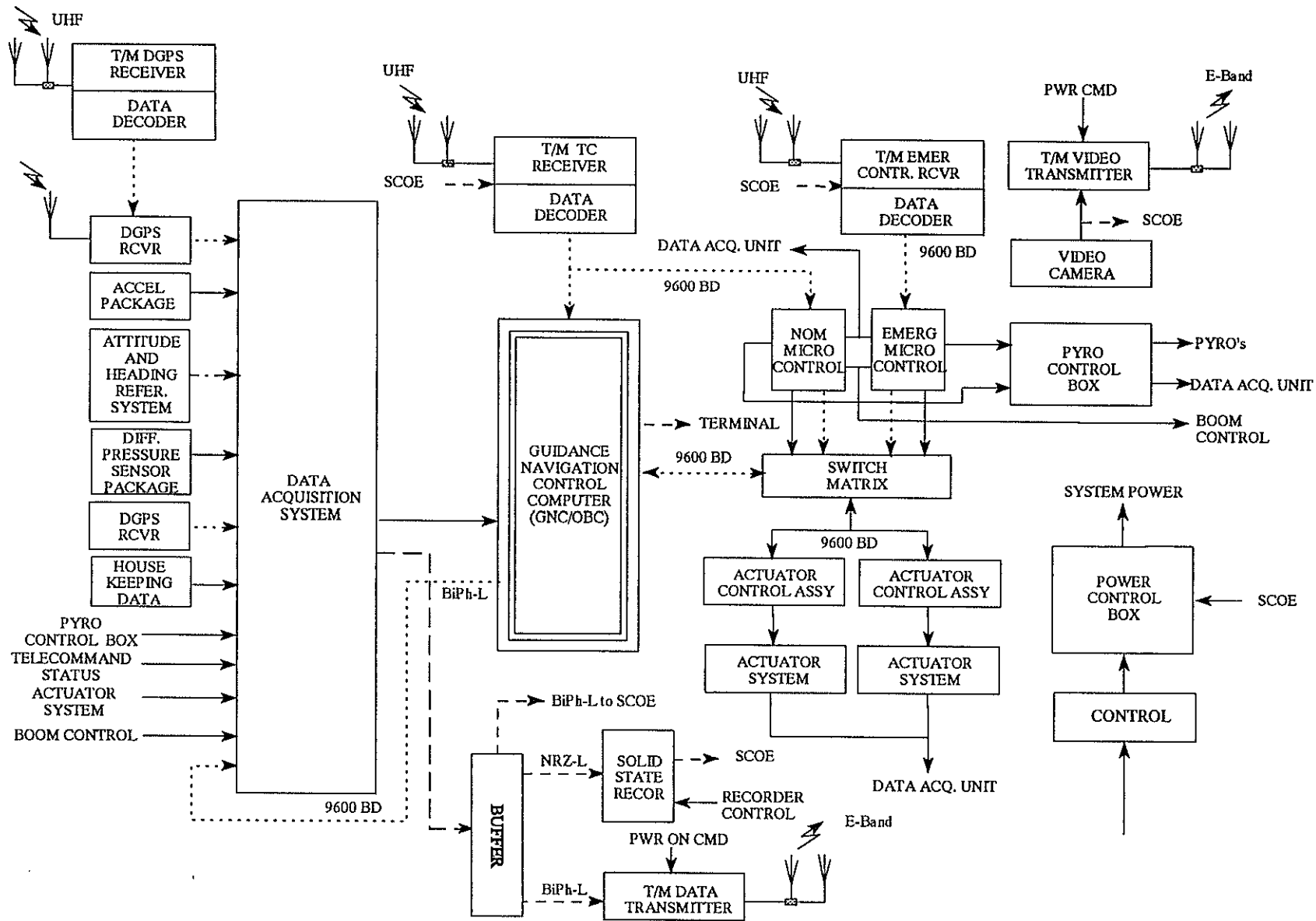



In the Application Software the Guidance and Navigation Module performs the Guidance and Navigation Function. The GNC has two modes: an autonomous and a remote mode. In the autonomous mode the GNC calculates steering commands based upon the sensor input data and as a result it issues the appropriate commands to the actuator system. The data rate of these commands to the actuator system is approx. 10 Hz. In override mode, i.e. under control from the ground, the GNC inputs the actuator commands as received via telecommands and transfer these commands to the actuator system.

Data transfer between the BSW and the ASW takes place by means of predefined service calls. A sequencer function in the BSW provides the timing function for the various tasks.

In order to meet the time schedule, parallel software developments, each assigned to a different team were performed. This approach required that the interfaces were frozen at the most detailed level at a very early stage. Therefore, it was decided not only to write the Interface Specification, but also include the coded interface files (in the form of "C" header files) and a set of additional coding rules and other more specific conventions [3].

The purpose of these arrangements was to provide a sound technical contract between the partners, allowing the parallel developments without the usual programmatic dependencies.

The architecture of the software running on the On-Board Computer is illustrated in figure 2. It shows the logical software levels of the software components. The ASW tasks run on top of the computer platform, consisting of the computer hardware and interfaces plus the BSW. The task of the BSW is to provide a Single Service Access Point interface to the ASW, thereby hiding implementation details from the ASW and providing the platform independent services that the ASW requires.

Data Acquisition System

The Data Acquisition System is one of the systems, where as much as possible existing system components are used. The Data Acquisition Unit scans all input channels at a predefined frequency, digitizes analog channels and outputs them into one serial data stream. By inserting the appropriate modules, this unit can accept a wide variety of analog and digital signals. These signals are derived from the installed transducers or other equipment. Each frame in the data stream is time stamped with an IRIG-B time code signal.

To avoid analog signal reconstruction errors, resulting from the sampling process, it is in general necessary to filter the unwanted dynamic components in the input signal. This can be done by using pre-sample filter boards, installed in the Pre-Sample Filter Unit.



Sensor Systems

To obtain the angular body rates, attitude and heading information with the accuracy, that is required for the Guidance and Navigation calculations a strap down inertial measurement unit is installed. For this a fiber optic gyro based Attitude and Heading Reference System is selected. By means of an electrolytic tilt sensor the long term drift of the attitude data is compensated. The output is applied to the Data Acquisition System. To obtain the initial heading information a flux valve is additionally installed in the payload.

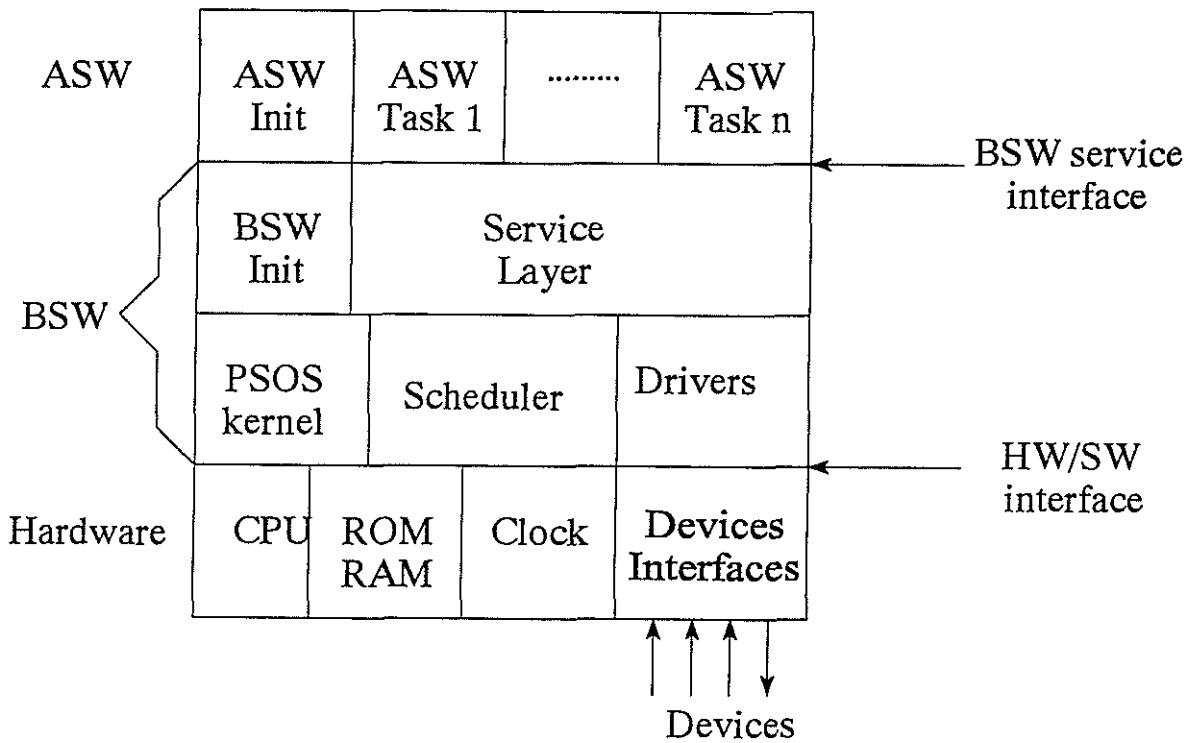

Fig. 2 OBC Logical Architecture

To determine the Angle of Attack, the Angle of Sideslip and the relative wind velocity a 5-hole probe is installed on an extendable boom to be clear of the turbulence area. By utilizing such a probe system and with sensitive differential pressure transducers the pressure distribution in the top of the sensor can be measured. From these pressure data the wind velocity, the angle of attack and the side slip angle can be calculated. Prior to the installation the calibration formulas are determined through wind tunnel tests.

A Laser Distance Measuring System measures the distance of the payload to the ground with such an accuracy that the flare manoeuvre can be initiated at the right moment. Such a system is normally not used for airborne applications. However, flight tests have shown that this system



can achieve the required accuracy and therefore it was preferred over the use of a radar altimeter system. The accuracy of the Laser Distance Measuring System is approx. 0.1 - 1 m, depending on the type of surface with a range up to 100 m, while the accuracy of a radar altimeter is approx. 3 ft.

A Global Positioning System serves as the primary navigation source for the Navigation and Guidance function. This system provides the required navigation parameters at a 1 Hz. update rate. To enhance the accuracy the position errors, as measured by a ground based GPS station shall be telemetered to the airborne system. In this way an absolute position accuracy can be achieved in real time of 2 meters (optimum performance) to 5 meters under worst case conditions.

A better position accuracy can only be obtained by using dedicated systems that can do dual frequency phase tracking. However, this solution will require post-processing techniques and therefore it cannot be used in real-time applications.

The GPS system must also cope with the requirement that the position data is available to the GNC computer at the moment of parafoil deployment, i.e. within 30 seconds after the release from the aircraft. This is accomplished by using a re-radiation kit, installed in the carrier aircraft that re-transmit the GPS signal from the aircraft system inside the cargo bay to the PTTV before release.

A number of other sensors are installed to measure housekeeping data as accelerations, temperatures, barometric pressure, impact shock, winch positions and battery voltages.

Data Storage

A Solid State Data recorder is used to record the serial, pulse coded data stream, generated by the Data Acquisition System. This solution is chosen to be independent of the status of the On Board Computer System. The memory capacity of 32 Mbytes is based upon the requirement of a minimum recording time of 30 minutes.

The Solid State recorder can retain the previously recorded data at least for four hours without the need for an external power supply.

Video System

A colour CCD pencil type video camera is installed on top of the PTTV to monitor the behaviour of the parafoil especially during the de-reefing phase. Since the video output of this camera is telemetered to the ground based station the operator can initiate an emergency sequence in case of a malfunction in the deployment of the parafoil.



Telemetry System

In order to monitor the behaviour of and to control the PTTV an extensive telemetry system, consisting of three up-links, operating in the UHF-band and two down-links in the E-band, is installed.

As already mentioned, a DGPS uplink telemetry system is used to enhance the accuracy of the GPS position measurements on-board the PTTV.

Remote control of the PTTV and activation of the emergency control system is accomplished using two more or less identical telecommand systems. In addition the nominal telecommand system is also used to change predefined coefficients in the application software of the GNC and to override the actuator position commands as output by the On Board Computer system under control of the autonomous GNC software. Using this mechanization the GNC software can be adapted to enhance some manoeuvres. The downlink data telemetry system transmits the data, acquired by the data acquisition system and the camera video to the ground based station for real time monitoring of the flight.

One of the most demanding requirements for the telemetry system was that from the moment of release and until the landing on the ground, telemetry of data in both directions was guaranteed. The maximum range to take into account for the budget calculation is 15 km.

Since the PTTV can tumble all way around during free fall conditions special attention was given to the locations of the antennas on the structure. Although, the best locations for the antennas could be found by means of radiation tests on a scaled PTTV model, it was decided to base the link budget for the telemetry links on conservative estimates of some parameters, such as the influence of multi path propagation and the influence of the PTTV on the antenna array pattern.

For the up-links and for the data down link acceptable link margins were calculated. The margin for the video link was found not sufficient to provide a video picture of good quality. However, it was considered as acceptable under the assumption that it is not a critical system and that a backup system is provided by monitoring and recording the deployment both by a video system on the ground and in the chase aircraft. Further, it was expected that the release should probably take place at a distance less than 10 km, resulting in an increase of the margin.

Nominal and Emergency Control System

In order to remotely control the PTTV and to initiate the emergency sequence a nominal and emergency control system is installed. This system consists of two identical channels, i.e. a nominal and an emergency channel. The decoded data streams from the two telemetry receivers are separately processed in this control system. In this way the requirement for a redundant safeguard function could be met (see figure 3).

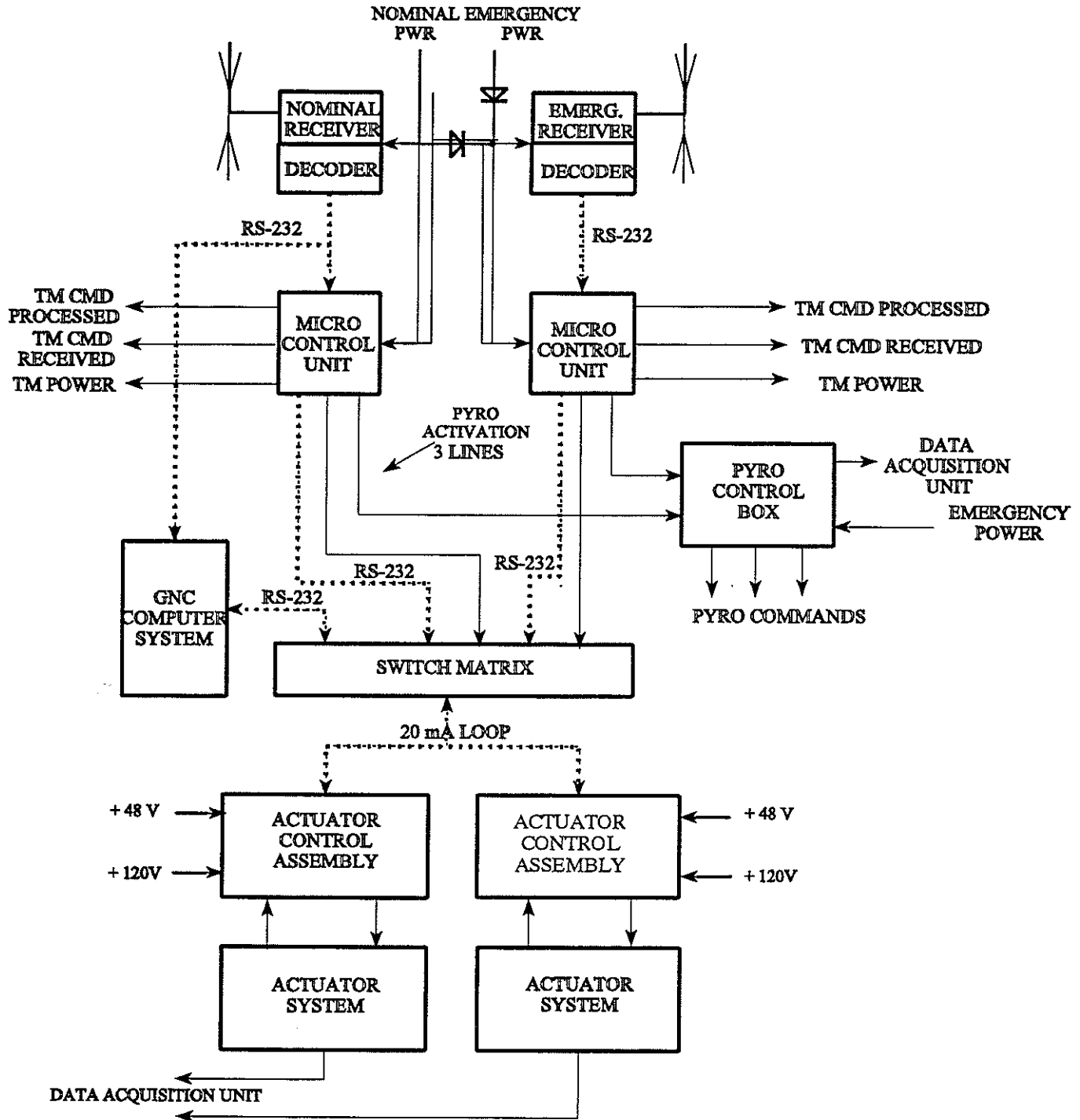

Fig. 3 Nominal and Emergency Control System



Based upon the header information in the received message the Micro Control Unit routes the commands to the actuator system or initiates the emergency sequence.

The switch matrix controls the serial data flow to and from the actuator system. The default mode is that the On Board Computer can command the actuator control assy's and monitor the replies from the actuator system. If actuator commands are sent through one of the Micro Control Unit channels then prior to send the commands to the actuator then the respective Micro Control Unit takes control of the switch. This mechanization prevents that in case of a faulty On Board Computer the PTTV cannot be remotely controlled.

However, if the message is a command to start the emergency sequence then it processes the message and subsequently outputs the proper emergency commands according the programmed time through the output port to the pyro control box.

Each Micro Control Unit has separate outputs to the pyro control box to arm the pyro's ignition circuit and to ignite the pyro's. So, to activate the emergency sequence the operator on the ground has to issue two commands. This will prevent an unintentional release command. A pyro control box is installed in the PTTV to activate the following pyrotechnic devices in case an emergency command is given:

- To launch the ejection devices for 3 small parachutes which operate as pilot chutes for the deployment of the free-fall stabilizer (drogue chute).
- To release the backup parachute.
- To extend the front risers of the parafoil in order to destroy the aerodynamic lift of the parafoil. The parafoil is not fully separated from the payload.

In addition the pyro box enables the release of the ballast weights. The actual moment of release of the ballast weights is controlled by of a barometric altitude switch that is preset to a safe release altitude.

Like the Micro Control Unit the pyro control box also consists of two identical circuits, each controlling one part of the connected dual pyrotechnic devices, in order to cope with redundancy. Further, it is assured, that independent what Micro Control Unit issues the command, both sections of the Pyrotechnic devices are fired.

Actuator System

The actuator system consists of two actuator control assemblies and two actuator drive units that drive winches to control the steering lines. The actuator servo controller receives its commands either from the On Board Computer or from the remote control system.



The servomotor in the actuator drive is coupled to the gearbox that drives the winch. Thereby, a resolver system, coupled to the axle of the motor serves as feedback control for the movements.

Each actuator drive motor is specified to provide 3000 N of power at a rate > 1.0 m/s.

In figure 4 the actuator system is shown.

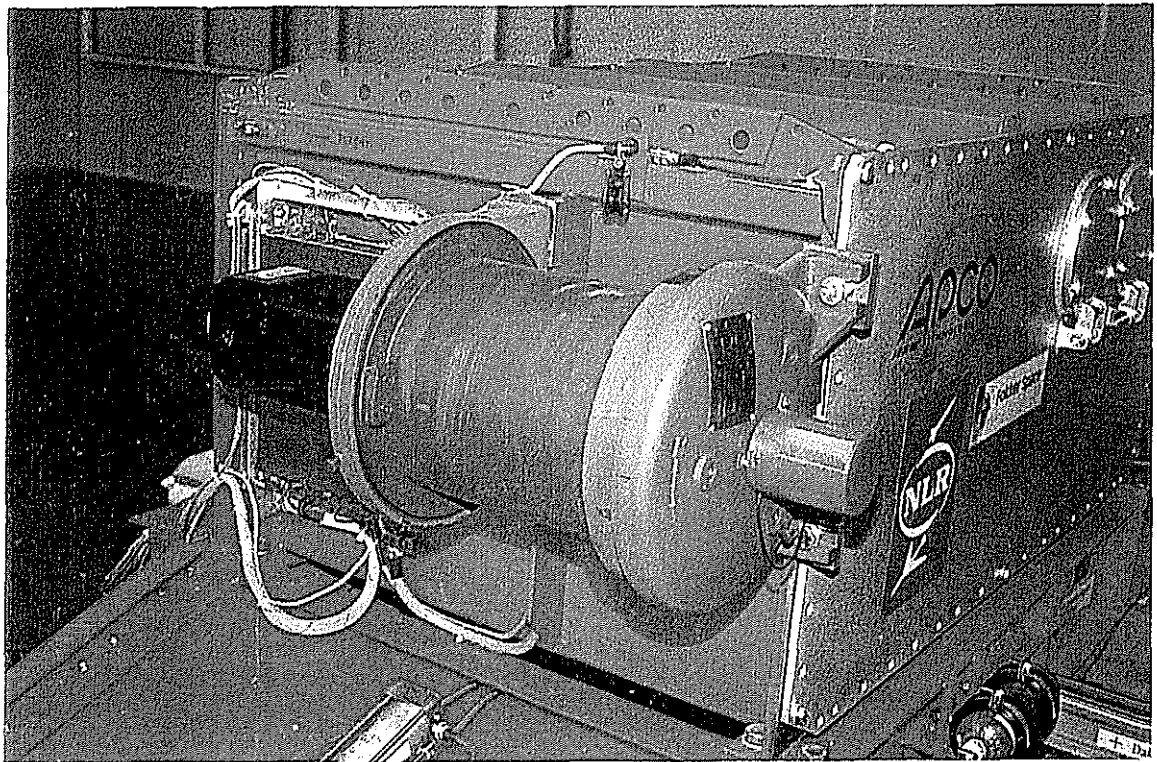

Fig. 4 Actuator Assembly



Power Supply

A number of batteries are installed to power the PTTV subsystems. The capacity of the batteries are chosen that the PTTV can operate for at least 30 minutes and that a number of manoeuvres, including a flare landing can be executed. The largest battery is the one for the actuator assemblies. This battery is capable of supplying 80 Amps peak @ 120 VDC.

A Power Distribution Unit gives accommodation to the various relays and circuit breakers and it distributes the power over the connected consumers.

To deal with redundancy separate batteries are provided for the emergency system.

If the PTTV is in the cargobay of the aircraft then the PTTV can run on aircraft power. This enables to power up the main instrumentation system for system alignment.

Mechanical Layout

The size of the parafoil of 160 m² defines the maximum weight of the mechanical structure, including the housing for the instrumentation, while the dimensions are limited by the size of the carrier aircraft. The D160 housing gives accommodation to all instrumentation equipment, including the batteries. All equipment is installed on a bottom plate that can be inserted into the housing, using a hoisting device.

The weight of the flight ready system is approx. 1800 kg, including 100 kg for the batteries. The housing is designed that it can withstand g-loads in a vertical axis up to 20 g.

By means of additional ballast weights the total weight can be increased to 3200 kg.

The extendable boom is installed just underneath the housing. One of the requirements for this boom was that it should rather stiff in order to minimize the contribution of errors on the measurements, caused by vibrations.

Between the D160 housing and the aircraft pallet impact damping devices are installed to reduce the magnitude of the shock on the instrumentation to max. 5 g during the landing.

Figure 5 gives an picture of the D160 housing without all the parachute packs, while figure 6 shows a picture of the flight ready system.

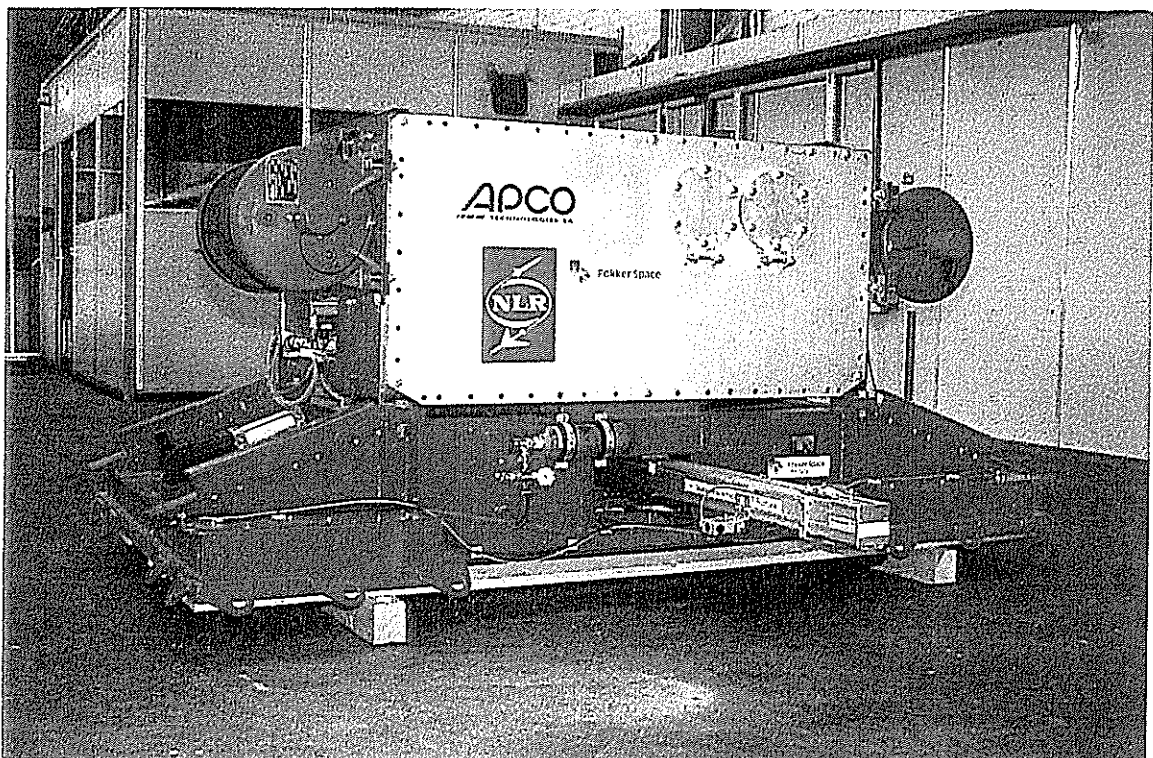

Fig. 5 D160 Housing

Alignment of equipment

In order to achieve the required accuracy a number of sensors must be properly aligned with the X, Y and Z-axes of the vehicle, e.g. the Attitude and Heading Reference System is installed within 0.1 degree along the X and Y axis and also within 0.1 degree in the vertical plane.

To cope with the required accuracy for the α and β parameters the five-holes probe and the boom is aligned within 0.1 degree of the X-axis (both in horizontal and in vertical plane). The probe is installed under an angle of 15 degrees with the boom to point the probe into the direction of the wind vector.

Ground Station

A System Check Out Equipment has been developed to aid the integration tests.

The same equipment is hooked up to the telemetry receiving station during the flight test and is used to monitor and log the received data. It can also generate the telecommands. After the flight the data, recorded on board the PTTV can be processed.

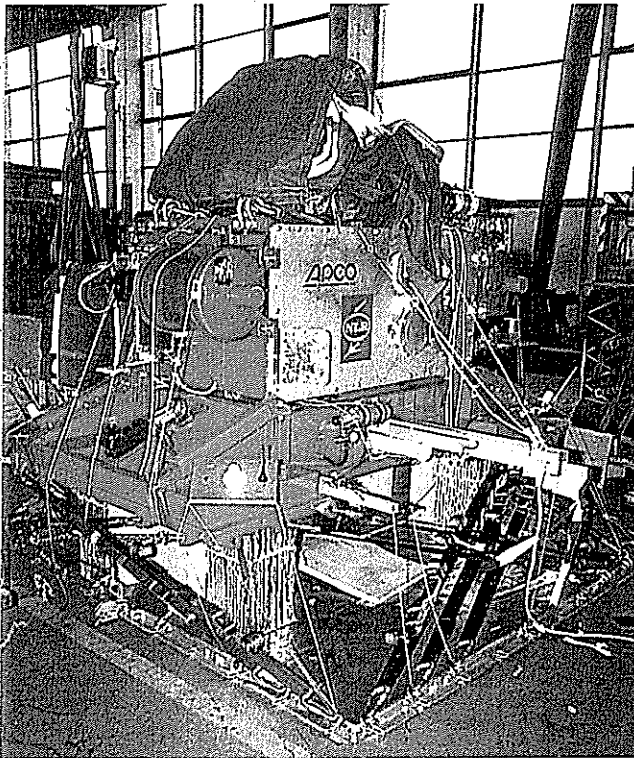

Fig. 6 Flight ready PTTV



Flight Test Programme

To achieve the objective a number of test flights with the D-160 module were scheduled.[4]

The common objectives for these test flights were:

- Study of the deployment process.
- Investigation of parafoil opening, inflation and de-reefing procedure.
- Analysis of steady and dynamic flight performances and stability of the entire parafoil/payload combination under different conditions.

These flights were carried out with different pay load mass and at different release altitudes up to a max. wing loading of 20 kg/m². The first series of flights were under remote control from the ground and allowed to gain sufficient confidence into the system reliability and the dynamic performance to perform safely the second series of autonomously controlled test flights. Besides the verification of the overall system behaviour the second batch of test flights contributed to the definition of limiting flight conditions for an advanced recovery system for manned space vehicles.

Prior to the D-160 flight test programme and after extensive functional ground tests a test flight with the D-160 module underneath a helicopter has been performed. For this test the module was fully operational, except for the parafoil and backup chutes.

The objectives of this flight were:

- verification of all RF links under flight representative conditions to demonstrate integrity of the RF links.
- Validation of the ground test results for the navigation chain, in particular differential GPS and the distance to ground measurement system.
- Verification of the entire safeguard function under flight representative conditions to demonstrate execution of the pyro current for parafoil release.

Implicitly the performance of the above mentioned objectives provided for:

- Functional demonstration of the test vehicle within the electrical environment of the test site.
- Verification of interfaces to the ground test equipment and facilities involved.
- Operational training for the actual flight test.



Conclusions

The instrumentation system, including transducers and the on-board computer system was based upon off-the-shelf equipment that is in use for flight testing of civil and military aircraft.

Using this well proven equipment developmental and financial risks were minimized at the expense of a sub optimal, but acceptable solution concerning volume and weight.

During the integration test no major problems were encountered. Only the programming of the actuators for the winches has required more effort than was expected.



References

- 1 Hummeltenberg, Behr, Starke
PTD Key System Requirements
Doc-No.: HT-TN-E9.7-106 DASA

- 2 P.M.N. Hollestelle
Electrical Architecture and Subsystem definition for PTTV, part 1
Doc-No.: HT-TN-E9.7-007-FSS

- 3 P.H.van Rossum
Electrical Architecture and Subsystem definition for PTTV, part 3
Doc-No.: HT-TN-E9.7-007-FSS

- 4 Behr
PTD test objectives
Doc-No.: HT-TN-E.7-012-DASA

