



Dedicated to innovation in aerospace

NLR-TP-2018-010 | September 2018

# Aircraft rudder optimization

A multi-level and knowledge-enabled approach

CUSTOMER: European Commission



NLR – Netherlands Aerospace Centre

## Netherlands Aerospace Centre

NLR is a leading international research centre for aerospace. Bolstered by its multidisciplinary expertise and unrivalled research facilities, NLR provides innovative and integral solutions for the complex challenges in the aerospace sector.

NLR's activities span the full spectrum of Research Development Test & Evaluation (RDT & E). Given NLR's specialist knowledge and facilities, companies turn to NLR for validation, verification, qualification, simulation and evaluation. NLR thereby bridges the gap between research and practical applications, while working for both government and industry at home and abroad.

NLR stands for practical and innovative solutions, technical expertise and a long-term design vision. This allows NLR's cutting edge technology to find its way into successful aerospace programs of OEMs, including Airbus, Embraer and Pilatus. NLR contributes to (military) programs, such as ESA's IXV re-entry vehicle, the F-35, the Apache helicopter, and European programs, including SESAR and Clean Sky 2.

Founded in 1919, and employing some 650 people, NLR achieved a turnover of 71 million euros in 2016, of which three-quarters derived from contract research, and the remaining from government funds.

For more information visit: [www.nlr.nl](http://www.nlr.nl)

# Aircraft rudder optimization

A multi-level and knowledge-enabled approach

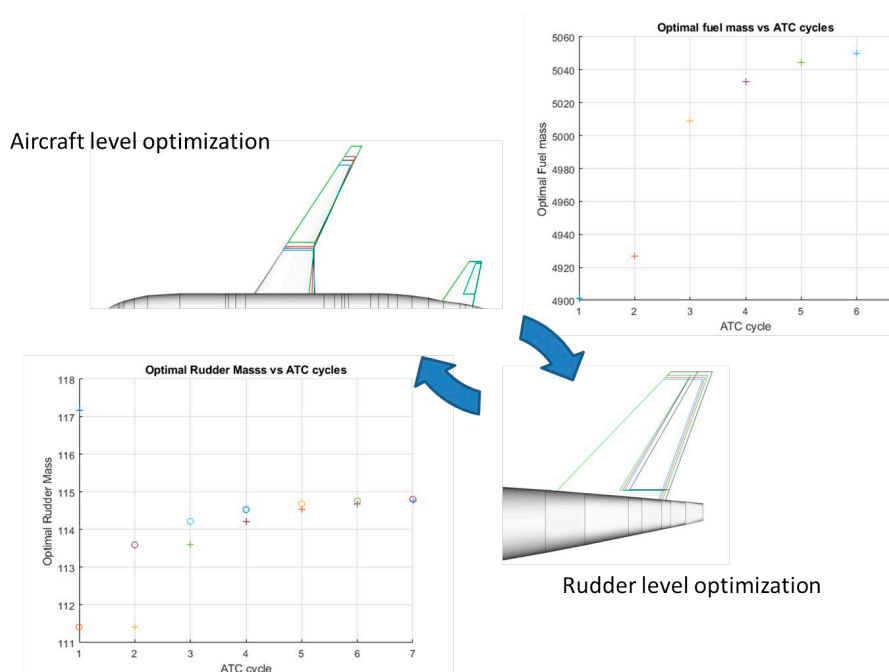

Figure 1 Overall aircraft and subsystem (here, rudder) coupled optimization.

## Problem area

Today, aircraft are highly advanced technological and competitive products that are developed by large and many multi-disciplinary teams of experts from many different companies, usually located in several countries. To reduce aircraft development costs, reduce lead times and to establish a more competitive supply chain, aircraft Original Equipment Manufacturers (OEMs) need to incorporate at an early stage in the design process the influence of various disciplines and structural details on the overall design performance. In particular, there is a need for efficient methods that address the problem of design optimization on aircraft level as well as on subsystem level, see Figure 1. A subsystem or part design that is optimal from its local perspective may not be optimal from the global aircraft perspective and vice versa. There is a need for an approach where global aircraft design objectives

### REPORT NUMBER

NLR-TP-2018-010

### AUTHOR(S)

A.J. de Wit  
W.F. Lammen  
W.J. Vankan  
H.S. Timmermans  
T. van der Laan  
P.D. Ciampa

### REPORT CLASSIFICATION

UNCLASSIFIED

### DATE

September 2018

### KNOWLEDGE AREA(S)

Computational Mechanics and Simulation Technology  
Aerospace Collaborative Engineering and Design

### DESCRIPTOR(S)

Multidisciplinary Design Optimization (mdo)  
Knowledge Based Engineering (kbe)  
Multi-level Optimization (MLO)  
Surrogate Models  
Collaborative Engineering

are met while keeping track of design optimization effects in other subsystems that may influence the overall design and vice versa.

## Description of work

In the AGILE project, advanced technologies for optimization, multi-disciplinary collaboration and knowledge-enabled engineering are developed and applied to preliminary aircraft design in various representative use cases.

Within Agile a multi-level optimization (MLO) approach has been applied to a component-airframe design problem of an aircraft rudder. First this problem was solved with a nested MLO. This optimization, including the rudder design tools was already described in NLR-TP-2017-370, but is repeated here for completeness and provides the reference case. Second, a multi-level optimization strategy called Analytical Target Cascading (ATC) is applied to the rudder design case.

## Results and conclusions

The multi-level optimization using ATC and the nested optimization method arrive at the same design optima. However, in the case of ATC the number of communication events between the global and the local level becomes smaller than with the nested approach. Limiting the number of communication events is needed in order to obtain an efficient collaboration between the aircraft OEM (performing the global optimization) and the suppliers (performing the local optimization). Hence, using MLO the OEM and suppliers are able to significantly reduce the development time of an aircraft subsystem.

## Applicability

The MLO approach described in this work can be used between OEM and suppliers - including the Dutch aircraft industry - to reduce development time of an aircraft or other complex system.

### GENERAL NOTE

This report is based on a paper to be published by Elsevier in Progress in Aerospace Sciences, 2018.

### NLR

Anthony Fokkerweg 2

1059 CM Amsterdam

p ) +31 88 511 3113

e ) info@nlr.nl i ) www.nlr.nl



Dedicated to innovation in aerospace

NLR-TP-2018-010 | September 2018

# Aircraft rudder optimization

A multi-level and knowledge-enabled approach

CUSTOMER: European Commission

## AUTHOR(S):

A.J. de Wit

NLR

W.F. Lammen

NLR

W.J. Vankan

NLR

H.S. Timmermans

NLR

T. van der Laan

GKN Fokker Aerostructures



P.D. Ciampa

DLR - German Aerospace Center

This report is based on a paper to be published by Elsevier in Progress in Aerospace Sciences, 2018.

*The contents of this report may be cited on condition that full credit is given to NLR and the authors.  
This publication has been refereed by the Advisory Committee AEROSPACE VEHICLES (AV).*

<b>CUSTOMER</b>	European Commission
<b>CONTRACT NUMBER</b>	636201
<b>OWNER</b>	NLR + partner(s)
<b>DIVISION NLR</b>	Aerospace Vehicles
<b>DISTRIBUTION</b>	Unlimited
<b>CLASSIFICATION OF TITLE</b>	UNCLASSIFIED

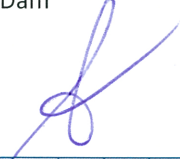
APPROVED BY :																				
AUTHOR			REVIEWER			MANAGING DEPARTMENT														
A.J. de Wit 			S. Zajac 			A.A. ten Dam 														
DATE	0	7	1	1	1	8	DATE	0	8	1	1	1	8	DATE	0	9	1	1	1	8

# Contents

<b>Abstract</b>	<b>1</b>
<b>Nomenclature</b>	<b>1</b>
<b>1 Introduction</b>	<b>3</b>
<b>2 Project context</b>	<b>4</b>
<b>3 The rudder design case</b>	<b>5</b>
3.1 Rudder MLO problem formulation	6
3.2 Aircraft and Rudder design analysis tools	7
<b>4 Nested optimization using surrogate models from aircraft and rudder design tools</b>	<b>10</b>
4.1 Surrogate models derived from the analysis tools	10
4.2 Deployment of the surrogate models	12
4.3 Aircraft rudder optimization results with the surrogate models	15
<b>5 MLO process via concept of Analytical Target Cascading (ATC)</b>	<b>20</b>
<b>6 Conclusions</b>	<b>29</b>
<b>Acknowledgements</b>	<b>31</b>
<b>References</b>	<b>31</b>





# Aircraft rudder optimization – a multi-level and knowledge-enabled approach

A.J. de Wit, W.F. Lammen, W.J. Vankan, H. Timmermans<sup>a</sup>, T. van der Laan<sup>b</sup>, P.D. Ciampa<sup>c</sup>

<sup>a</sup>*NLR - Netherlands Aerospace Centre, Anthony Fokkerweg 2, 1059 CM, Amsterdam, the Netherlands*

<sup>b</sup>*GKN Fokker Aerostructures, PO Box 1, 3350 AA Papendrecht, the Netherlands*

<sup>c</sup>*DLR - German Aerospace Center, Hein-Saß-Weg 22, 21129, Hamburg, Germany*

---

## Abstract

In the AGILE project, advanced technologies for optimization, multi-disciplinary collaboration and knowledge-enabled engineering are developed and applied to preliminary aircraft design in various representative use cases of some conventional and unconventional configurations (like strut-braced wing, box-wing and blended-wing). This paper describes the application of a multi-level optimization (MLO) strategy based on analytical target cascading (ATC) to aircraft rudder design. As a reference, part of previous work, a traditional nested optimization method is applied as well. Both methods arrive at the same design optima. In the case of ATC the amount of interaction between the global and the local level is reduced. The MLO is illustrated by applying surrogate models that were derived from aircraft and rudder design analysis competences available from AGILE. The surrogate models are deployed through a specific repository that facilitates a knowledge-enabled approach. The rudder design case illustrates that applying MLO provides insight into the coupled design problem both for the OEM and for the supplier through establishing a common interface in the design process, reducing the risk of late changes and minimizing the number of interaction events.

*Keywords:* multi-level optimization (MLO), multi-disciplinary design optimization (MDO), analytical target cascading (ATC), global-local design

---

<b>Nomenclature</b>	$\tau_{ATC}$	Objective change tolerance
○ element by element multiplication of vectors	$\leq$	design variable lower bound
$\leq$ design variable upper bound	$\mathbf{C}$	Consistencies
$\leq$ design variable upper bound	$\mathbf{R}$	Responses
5 $\pi$ Penalty function	$\mathbf{T}$	Targets
$\tau$ Consistency error tolerance	$\mathbf{v}$	Lagrange multipliers

	$w$	Penalty parameters		DoE	Design of Experiments
	$b$	Aircraft wing span	35	FEM	Finite Element Method
15	$c_{rud}$	Rudder chord		HDOT	Hinge-System Design and Optimization Tool
	$f$	Global objective function			
	$f_{obj}$	weighted sum objective function		KA	Knowledge Architecture
	$F_{rud}$	Rudder force	40	KADMOS	Knowledge- and graph-based Agile Design for Multi-disciplinary Optimization System
20	$h$	output rudder design tool			
	$m_{fuel}$	Aircraft fuel mass		LHS	Latin Hypercube Sampling
	$m_{rud}$	Rudder mass		MDO	Multi-disciplinary Design Optimization
	$m_{VTP}$	Vertical Tail Plane mass	45		
	$w_1, w_2$	weight constants for weighted sum objective function		MLO	Multi-Level Optimization
25				OAD	Overall Aircraft Design
	ADF	AGILE Development Framework		OEM	Original Equipment Manufacturer
	AML/AMLoad	Aeroelastic Modelling and Loads analysis tool		RMSE	Root Mean Square Error
				SQP	Sequential Quadratic Programming method (optimization algorithm)
30	ATC	Analytical Target Cascading			
	CMDOWS	Common Multidisciplinary Design Optimisation Workflow Schema	55	XDSM	eXtended Design Structure Matrix

## 1. Introduction

Modern aircraft design and development is a complex process that involves an extended supply chain of different companies. Within this supply chain a distinction is made between the aircraft Original Equipment Manufacturer (OEM) and the suppliers of (sub)systems and components. Each supplier is responsible for its own (sub)system design. The OEM is responsible for the overall aircraft design and the interfacing between the overall aircraft and the (sub)systems.

Dividing the design process of an aircraft (sub)system via (rigid) interfaces of collaboration and data exchange between OEM and suppliers has the advantage of allowing (sub)system suppliers to advance in their specific expertise separately from the OEM. From a supplier perspective, this decomposition may lead to an optimal system or subsystem design. However, from an OEM perspective it may result in a non-optimal integrated design.

To avoid costly redesign iterations it is necessary to optimize the (sub)systems and the overall aircraft in an integrated way. This paper presents a Multi-Level Optimization (MLO) method to integrate the (sub)system design optimization within the global aircraft design optimization. Based on previous work reported in [1] an aircraft rudder design is considered representing a subsystem design of a rudder within the overall aircraft design. Within this use case a hierarchy and coupling is embedded in the design problem.

The paper is organized as follows:

- Section 2 describes MLO in the context of optimization technologies as developed in the EU Horizon2020 project AGILE [2].
- Section 3 formulates the rudder design optimization problem.
- Section 4 introduces surrogate modeling to the aircraft analysis and rudder design tools available in AGILE, as well as the (knowledge-enabled) deployment and sharing of these surrogate models in MDO context.
- Section 5 describes an MLO method based on Analytical Target Cascading (ATC) and applies it to the rudder design optimization problem.
- Section 6 presents the main conclusions.

## 2. Project context

AGILE (Aircraft 3rd Generation MDO for Innovative Collaboration of Heterogeneous Teams of Experts, see [2] and [3]) is a European research project in the frame of the Horizon2020 program. The high level objective of AGILE is to obtain a significant reduction in development time and costs of aircraft through the implementation of a more competitive supply chain in the early stages of the design.

AGILE targets at multidisciplinary optimization using distributed analysis frameworks. The project is set up to prove a speed up of 40% for solving realistic MDO problems compared to the state-of-the-art. AGILE considers various use cases on realistic preliminary aircraft design for both conventional configurations and some unconventional configurations (strut-braced wing, box-wing and blended-wing). The focus of AGILE is on the development of technologies for advanced optimization, collaboration and knowledge-enabled information. The optimization technologies that are investigated in AGILE include robust optimization, surrogate based optimization, multi-objective optimization and multi-level optimization (MLO).

MLO technologies are considered to address the coupled problem of design optimization from aircraft to component level. This coupled problem includes the setup of aircraft design and analysis processes on multiple levels to enable consistent design evaluations. Moreover, multiple objectives and constraints e.g. for cost analyses or robust design on the aircraft and component levels may be included. Another challenge for the MLO technologies is the multi-partner collaboration between aircraft OEM and suppliers. Therefore, AGILE investigates the application of collaborative multi-partner simulation infrastructures for various design tools, based on commercial and in-house developed software. The AGILE industrial partner Fokker has provided an MLO test case for integrated component-airframe design optimization. This test case is introduced in the next section, Section 3.

### 3. The rudder design case

An MLO test case for integrated Component-Airframe design optimization has been defined by the industrial AGILE partner Fokker, who is a supplier of aircraft structural components and movables to aircraft OEMs. The aircraft rudder design is based, among others, on the rudder planform specifications (e.g. rudder chord, span, outer mold line) and the applicable rudder loads (e.g. rudder aerodynamic forces, hinge forces, actuator forces). This rudder design case was used already in previous work [1] and is explained in the text below for completeness.

Both planform specifications and applicable rudder loads are provided by the aircraft OEM. The rudder loads follow from the prescribed certification load cases (see FAR Part 25.147[4]). One such certification load-case for rudder design is "Flying with one engine inoperative". In this case the rudder needs to be able to compensate the yaw moment of the aircraft resulting from asymmetric thrust caused by one engine being inoperative, see Figure 1.

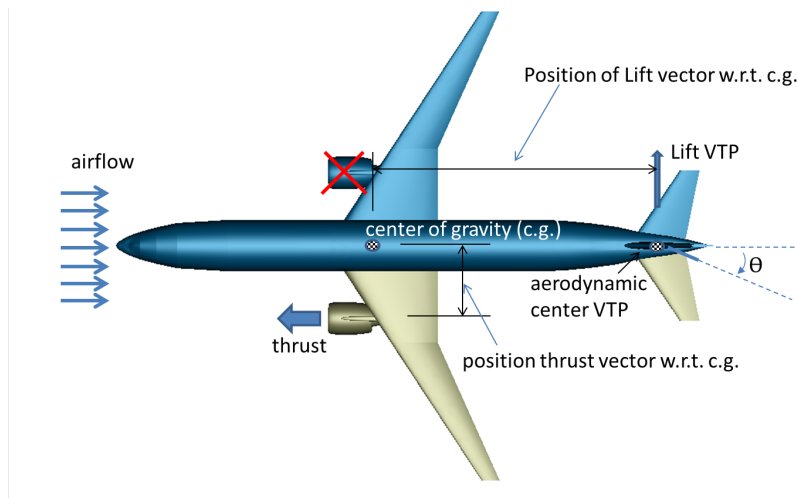

Figure 1: Yaw moment caused by asymmetric thrust. The case illustrated here is due to a twin-engine airplane losing one engine's thrust.

On the level of the rudder design, the rudder structure is optimized for weight and cost, under the constraints that the requirements on specifications and loads are fulfilled. On the level of the aircraft design, the whole aircraft structure is optimized, e.g. for weight and drag, using the main wing planform parameters as design variables.

In the present study a simplified version of the above mentioned MLO use case is considered to demonstrate the essence of the approach. A variation at aircraft level design is limited to the main wing span as design variable. In addition, a constant relative span-wise position of the engine is assumed. This way, for the "one-engine-inoperative" load case an increase in wing span has

a direct effect on the required rudder force due to the larger yaw moment. In addition, the rudder planform may need to be changed if the rudder deflection angle reaches its maximum when compensating the aircraft yaw moment.

On the level of the rudder design, the rudder structure is optimized for the loads corresponding to the "one-engine-out" case. Furthermore, costs and manufacturing considerations are considered to arrive at a rudder design. A change in rudder design may impact the aircraft design. For example, a change in rudder weight has an effect on the overall aircraft weight and balance. This interaction is illustrated in Figure 2.

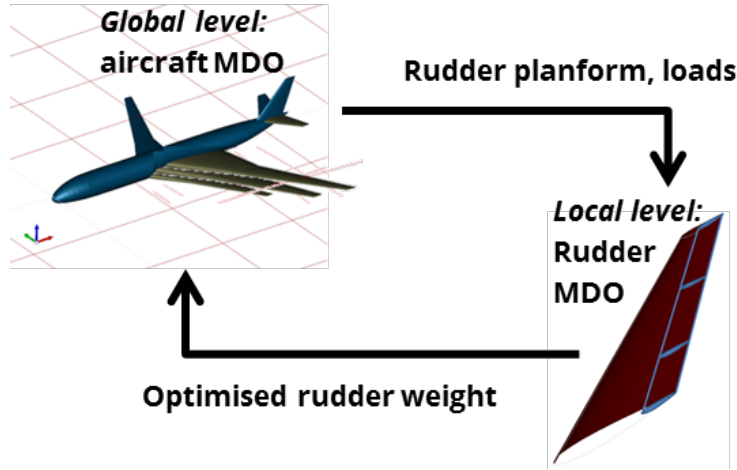

Figure 2: Global and local levels in aircraft and rudder design.

### 3.1. Rudder MLO problem formulation

Mathematically, the aircraft rudder MLO use case can be formulated as follows. To demonstrate the essence, the number of design variables is kept to a minimum.

Assume that  $f(b, m_{rud})$  is some global aircraft optimization objective that depends on the global design variable wing span  $b$  and in some way on the rudder mass  $m_{rud}$ . The objective function  $f$  is based on aircraft total weight and fuel burn. Assume that the rudder mass depends on the rudder planform, represented via rudder span (fixed) and rudder chord (design variable). Furthermore, rudder mass depends on the (resulting) rudder force (representing the loads) for which it has been designed:

$$m_{rud} = m_{rud}(c_{rud}, F_{rud}) \quad (1)$$

With rudder chord  $c_{rud}$  and rudder force  $F_{rud} = F_{rud}(c_{rud}, b)$ , assuming that the rudder force depends both on the rudder chord (representing the rudder planform) and the wing span (as explained earlier). Then the global aircraft level optimization problem is formulated as follows:

$$\begin{aligned}
& \min_{b, c_{rud}} && f(b, m_{rud}(c_{rud}, F_{rud}(c_{rud}, b))) \\
\text{subject to:} &&& g(b, c_{rud}) \leq 0 \quad (2) \\
\text{bounded by:} &&& \underline{b}, \underline{c}_{rud} \leq b, c_{rud} \leq \bar{b}, \bar{c}_{rud}
\end{aligned}$$

165 With  $g$  a (nonlinear) constraint function that could be based on the maximum rudder deflection in combination with the applicable load case. In its turn function  $m_{rud}$  could be defined by the optimized rudder mass, as calculated by the rudder supplier:

$$m_{rud}(c_{rud}, F_{rud}) = \min_{\mathbf{x}_l} h(\mathbf{x}_l, c_{rud}, F_{rud}) \quad (3)$$

170 The function  $h$  is the local rudder level objective function. In this case  $h$  represents the output of the rudder design tool calculation at the supplier. At present, this design tool calculates an optimized rudder design and therefore does more than just analyzing the design. Several local design variables  $\mathbf{x}_l$ , e.g. skin thickness, number of ribs and hinges, are considered in this tool.

175 The parameters  $c_{rud}$  and  $F_{rud}$  are either constant parameters for the local objective function  $h$  - as formulated above - or could be part of local constraint functions, depending on the implementation of the local rudder design and optimization tools.

180 The optimization problem formulation described above is based on a nested approach. The local level optimization is embedded in the global level optimization. The functions introduced depend on output from several analysis tools. These tools are introduced in the next subsection.

### 3.2. Aircraft and Rudder design analysis tools

185 Within the AGILE project the design analysis is performed with several analysis tools provided by the AGILE partners. This analysis is carried out both on the aircraft level and on the rudder level. The tools that have been used for this particular study are:

- Overall Aircraft Design (OAD) analysis capability, provided by DLR as a service.
- 190 • Aeroelastic Modelling and Loads (AMLoad) analysis tool [5], provided by NLR.
- Hinge-System Design and Optimization Tool (HDOT) [6], provided by Fokker for rudder MDO.

195 The procedure to evaluate a design using these 3 tools is to first carry out an Overall Aircraft Design (OAD) analysis. The OAD analysis is a multidisciplinary analysis including full aircraft synthesis, tail plane resizing (e.g. following

from the specified rudder mass), mass distribution and mission analysis. It produces aircraft design data in the CPACS format as used in AGILE, see [7]. Second, calculation of the loads on the rudder and the deflection of the rudder is carried out via AMLoad. AMLoad is an aeroelastic modelling and loads tool. It can read the aircraft design data in CPACS format and extend it with loads analysis results. Third, the rudder design is carried out via HDOT. HDOT performs a structural analysis of the rudder and carries out a design study where relevant objective and constraint functions can be chosen. In the present study, HDOT returns an optimized rudder mass to the OAD analysis. Figure 3 depicts the workflow of the analysis tools, their interactions and the exchange of variables in the multi-level context. The remainder of this chapter further discusses the analysis tools that are applied to the design case.

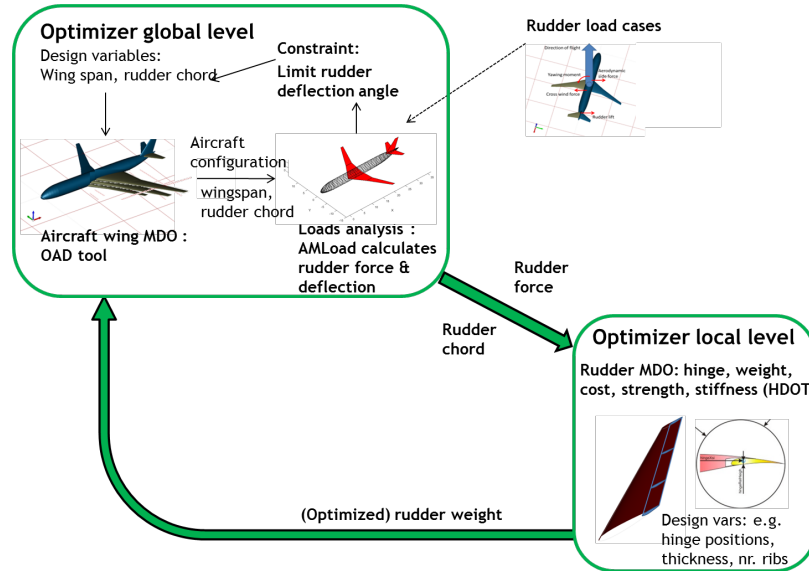

Figure 3: Workflow scheme of the aircraft rudder design tools in MLO context.

The OAD analysis is composed by distributed design competences available at DLR. These competences are targeted for preliminary aircraft design activities. The competences included in the current study comprise both conceptual aircraft design methods [8] and physics based modules. Examples of the latter are aero-structural FEM based capabilities [9]. The OAD process is integrated as a fully automated multi-level workflow. In the global overall aircraft synthesis process the OAD process accounts for the input provided by the local level.

The OAD analysis is used for calculation of the global design objective. For the present study this global design objective is chosen as fuel mass and vertical tail mass. An aircraft wing MDO with varying wing span has been chosen as global-level design case. However, the OAD tool can be used to carry out studies



on other design parameters as well.

Aeroelastic Modelling and Loads (AMLoad)[5] is used for calculation of the loads on the rudder and the deflection of the rudder. As a critical case a one engine inoperative load case has been chosen. It is assumed that this case provides the critical rudder loads. The rudder deflection is used for calculation of the global constraint function. The rudder deflection may not exceed a certain maximum value. The rudder loads (represented by rudder force) are provided to the rudder level.

The Hinge-System Design and Optimization Tool (HDOT) [6] optimizes rudder hinge design with respect to rudder mass. As input the tool requires loads that are applied to the rudder hinges. Internally the tool then carries out structural analysis to determine load paths and improve the size and position of the hinges. The tool is used internally at Fokker and can be used for other type of design studies as well.

The workflow has an embedded hierarchy for which a formulation of a multi-level optimization can be derived. The OAD tool and AMLoad represent the global analysis tools, which are to be steered by a global optimizer. The HDOT represents the local level optimization. The rudder planform (here represented by rudder chord, for simplicity) and rudder force are specified as parameter values. They are fixed during the local optimization process itself. In Section 4 surrogate models are introduced to perform a nested optimization of the aircraft rudder design. These techniques support the final multi-level optimization formulation in Section 5.

#### 4. Nested optimization using surrogate models from aircraft and rudder design tools

245

For completeness and to make this paper self-contained, the nested optimization problem - part of previous work [1] - is repeated here. The present section introduces the problem using the surrogate models that are used to replace the computationally expensive expert tools. A surrogate model is an analytical formula that replaces a complex model by means of data fitting, see e.g. [10] or [11]. Consequently, a surrogate model requires only small computation time. This is particularly useful in case a complex analysis (e.g. HDOT) is applied multiple times as part of an optimization loop. In this study surrogate models are used for the global level analysis tools OAD and AMLoad and the local level analysis and optimization carried out within HDOT.

250

255

##### 4.1. Surrogate models derived from the analysis tools

A Design of Experiments (DoE) based on Latin Hypercube Sampling (LHS) has been created for analyzing 30 aircraft configurations with the OAD capability. In the parametric aircraft model the wing area is kept fixed while varying wing span as well as the rudder root chord and the rudder mass. During the OAD simulations the aircraft mission is repeated for each analysis.

260

The OAD simulations provided a data set of 30 aircraft configurations. This data set has been analyzed and relations between changing parameters and computed output have been found. The relations identified are between the input parameters; rudder mass and wing span, and the output parameters; fuel mass and Vertical Tail Plane (VTP) mass. The fuel mass consists of the total mass of fuel that is needed by the aircraft to fly a fixed mission profile. The VTP mass consists of rudder mass and fixed tail section mass. The relation between input and output parameters is plotted in Figure 4.

265

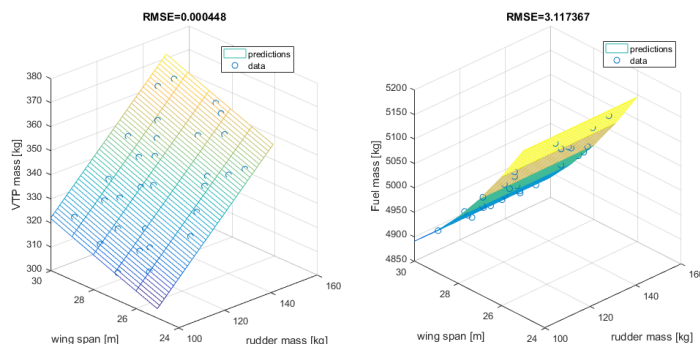

Figure 4: Surrogate model prediction of VTP mass (left) and fuel mass (right) derived from the OAD simulation data. In addition, the root mean squared error (RMSE) of the surrogate model prediction is displayed.

270

Figure 4 shows that for increasing wing span the size of the VTP mass increases. This is due to the larger rudder deflection necessary to compensate

placing the engines more outboard. The fuel mass increases for increased rudder mass, but decreases for increased wing span. The latter is due to increased efficiency of the wings during cruise (less induced drag).

275 The data coming from the OAD simulations has been fitted by polynomials. These polynomials have a relatively small value of the root mean squared error (RMSE) when evaluated on the fitting data set. The fitting data set covers the points that were computed for the DoE of 30 aircraft configurations. Points that are evaluated using the polynomials are plotted together with the fitting data set in Figure 4. The plotted data and evaluated points show the good agreement between polynomial fitting and fitting data set.

280 The OAD simulation data has been further processed by AMLoad in order to calculate the corresponding rudder loads and rudder deflection for each aircraft configuration. From the AMLoad results relations have been derived between the rudder root chord, the wing span and the rudder lateral force. In addition, relations have been identified between the rudder root chord, the wing span and the rudder deflection. These relations are shown in Figure 5. The latter relation is important for the optimization constraint that follows from the rudder load case: the rudder deflection has an upper limit. This means that if the deflection exceeds this limit a larger rudder i.e. a larger rudder chord is needed.

290

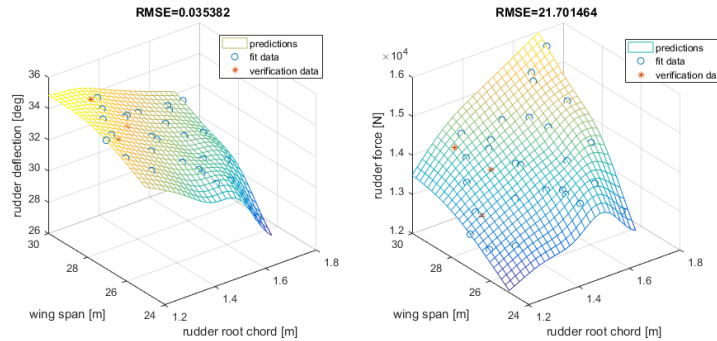

Figure 5: Surrogate model prediction of rudder deflection (left) and rudder load (right), derived from the AMLoad simulation data. In addition, the root mean squared error (RMSE) of the surrogate model prediction is displayed.

The data has been fitted via an interpolating kriging model with a 2<sup>nd</sup> order polynomial regression and Gaussian correlation function. The surrogate model is based on an interpolating function. The predicted points from this interpolating function have been verified by calculating the RMSE on randomly chosen data points. These data points were excluded from the fitting data set (see the red stars in Figure 5). This results in an RMSE that is three orders of magnitude smaller than the actual data.

295 Additional verification of the surrogate model has been performed with the leave-one-out method. With this method one data point is excluded from the fitting set. This data point is reserved to verify the predicted point coming from the surrogate model. The excluded data point is shifted over the complete

300

data set, resulting in 30 fits (each time performed on the remainder of 29 data points) and 30 verifications. The RMSE values of these 30 verifications are approximately 0.14 degrees for rudder deflection and 60 N for the rudder force prediction. The data fit and verification have been carried out using NLR's in-house MATLAB-based tool MultiFit [10].

On the rudder level, HDOT calculates the optimized mass of the rudder hinge assembly. Rudder loads (e.g. force) and rudder plan form (e.g. chord) can be provided as parameter values. Figure 6 shows the relation between the optimized rudder hinge mass and rudder lateral force. This relation is interpolated by piecewise polynomial functions.

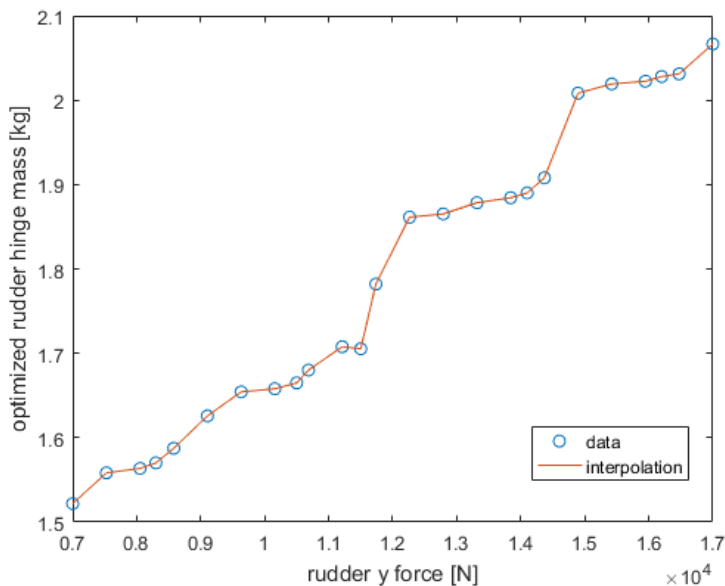

Figure 6: Surrogate model prediction of optimized rudder hinge mass, based on HDOT data.

Data of the full rudder mass were not available. Instead normalized data showing the effect of design changes was provided. Therefore, the HDOT results are scaled to the level of a typical rudder mass, see Figure 7.

#### 4.2. Deployment of the surrogate models

The three surrogate models described in the previous section were created using MultiFit [10], a fitting tool. By using the export function of MultiFit, C implementations of the surrogate models were derived as well. The exported C code was compiled into a binary version of each surrogate model, ready for deployment.

The deployment versions have been shared through a surrogate model repository (SMR). The SMR was developed in AGILE to support the collaboration

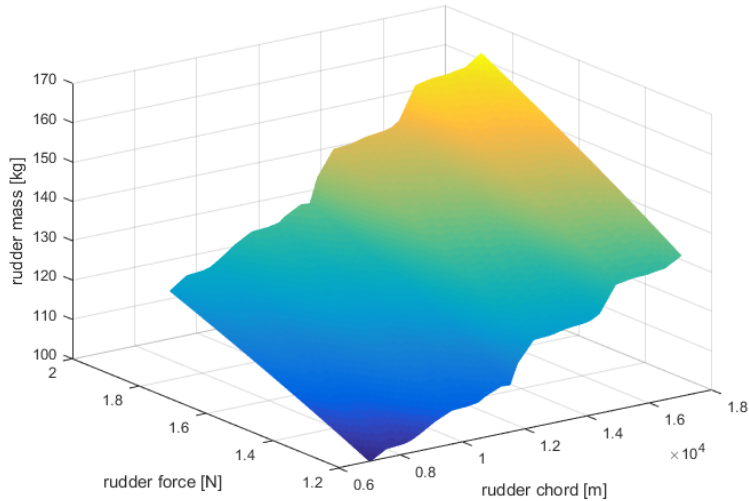

Figure 7: Prediction of optimized rudder mass, based on scaling of HDOT surrogate model.

between partners by shared use of surrogate models; see [12] and [13] for details. If several surrogate models (e.g. representing different design analyses) are shared between partners (e.g. OEM and suppliers), this preferably needs to be performed in a managed way to prevent using the wrong model. Moreover, surrogate models must be applied with care. The bounds of the allowed input space of a surrogate model need to be clearly specified (e.g. to avoid extrapolation). Furthermore, the prediction accuracy of the outputs of the surrogate model must be specified, so that the user has a clear idea of its applicability, quality and limitations. In this context, additional information about the verification of the surrogate model (verification method and results) is useful.

Figure 8 shows a screenshot of the specification of an AMLoad surrogate model for prediction of the rudder deflection and rudder force, as uploaded to the SMR. Information about the purpose and the background of this surrogate model is provided. Furthermore, the input and output variables are specified. For the input variables the allowable range is specified. For the output variables the verification results are given, in this case applying two verification methods. The verification results provide information about the accuracy of the surrogate model. In addition this page allows the user to download a binary executable version of the surrogate model for use on a Windows computer.

In similar fashion the OAD surrogate model and the rudder surrogate model have been uploaded to the SMR. The AGILE project is deploying a collaborative MDO design system, called the AGILE development framework (ADF). The corresponding Knowledge Architecture (KA) includes a common XML-based workflow definition schema for integrating and connecting MDO servi-

**Analysis info**  
Rudder force and deflection calculation for a set of 30 CPACS files produced by the DLR Overall Aircraft Design (OAD) tool.

**Method info**  
Kriging interpolation: 2nd order polynomial regression with fit, performed with MultiFit.

**Guidelines**  
To be used for rudder multi-level optimisation. Inputs should stay within their specified bounds.

**Input parameters**

Name	Type	Description	Extra
rudder_cRoot	float	rudder root chord	Min: 1.2 Max: 1.7 Unit: m
wing_span	float	aircraft wing span	Min: 25 Max: 30 Unit: m

**Output parameters**

Name	Type	Description	Extra
rudderDefl	float	rudder deflection	Min: Max: Unit: deg
rudderForce	float	rudder lateral force	Min: Max: Unit: N

**Verification**

**Verifier**  
wim.lammen@nlr.nl  
Method: Leave-one-out

Verification output	Output parameter	Value
RMSE	rudderDefl	0.14
RMSE	rudderForce	60

Method: 3 point validation set, excluded from fit data set

Verification output	Output parameter	Value
RMSE	rudderDefl	0.03
RMSE	rudderForce	22

**Execution mode** downloadable executable

[Save win64 binary](#)

**Submitter:** lammen

Optional: Export workflow

[Save client CMDOWS.xml](#)

Figure 8: Upload of the AMLoad surrogate model in the SMR with meta information.

ces: Common Multidisciplinary Design Optimisation (MDO) Workflow Schema (CMDOWS). Further details on the KA and the ADF can be found in [7]. In order to interface to the ADF and the Knowledge Architecture, the SMR provides  
 350 a CMDOWS export facility. The export button can be seen at the bottom of Figure 8. As such all meta-information of the surrogate model as stored in the SMR is exported in a CMDOWS XML file. With this XML file the surrogate model can be used as stand-alone MDO service.

Extracting the meta information of all three surrogate models from the SMR  
 355 in CMDOWS format results in a neutral workflow specification of the three interconnected surrogate models. This workflow specification can be interpreted and visualized by other tools developed in AGILE: knowledge- and graph-based Agile Design for Multidisciplinary Optimization System (KADMOS) and VISu-  
 alization TOol for MDO Systems (VISTOMS).

Figure 9 depicts the eXtended Design Structure Matrix (XDSM) [14] view of  
 360 the interconnected surrogate models. This picture shows the data flows between the surrogate models when executed in a workflow. The coordinator block represents the optimizer which is discussed in section 4.3. The scheduling as depicted in Figure 9 is applied to derive the compound objective function for  
 365 the nested optimization, see subsection 4.3.

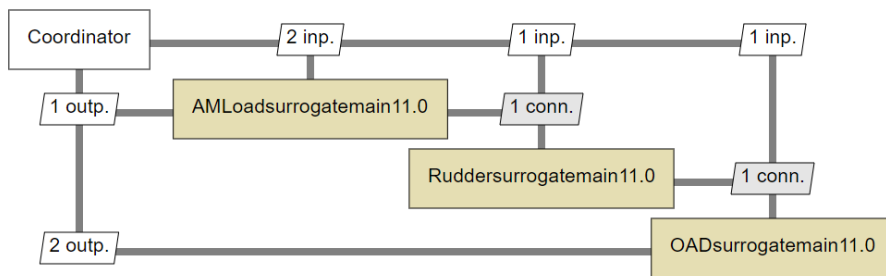

Figure 9: XDSM view of the surrogate-based optimization workflow.

Figure 10 provides an alternative view on the same workflow, using the Sankey diagram [15]. Both graphs have been created by applying KADMOS/VISTOMS to the CMDOWS files exported from the SMR. The SMR facilitates a knowledge-enabled approach to the aircraft rudder MLO use case.  
 370 Specifically when combining the meta information of the surrogate models as available from the SMR with KADMOS/VISTOMS automatically provides a clear view on the applicable MDO workflow.

#### 4.3. Aircraft rudder optimization results with the surrogate models

To arrive at an optimization problem formulation we take a closer look at  
 375 the data that was plotted in Figure 4. The data plotted in this figure shows that a change in wing span changes the fuel mass. However, the rudder mass is only slightly changed. Instead, the VTP mass changes noticeable when changing

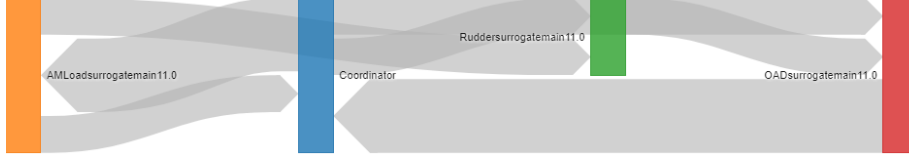

Figure 10: The Sankey diagram for the surrogate-based optimization workflow.

rudder mass and changing wing span. Therefore, both fuel mass and VTP mass are taken into account in the optimization problem formulation.

380 As objective function a weighted sum of the aircraft fuel mass [kg] and the vertical tail plane (including rudder) mass [kg] is used. Using  $w_1$  and  $w_2$  as the weight constants, the objective function is written as:

$$f_{obj} = w_1 * m_{VTP} + w_2 * m_{fuel}. \quad (4)$$

385 The compound objective function  $f_{obj} = f_{obj}(c_{rud}, b)$  is calculated by performing the following steps:

- Calculate the rudder force as function of rudder root chord  $c_{rud}$  and wing span  $b$ , using the AMLoad derived surrogate model, see Figure 5.
- Calculate the (locally) optimized rudder mass as function of the rudder force, using the HDOT derived surrogate model, see Figure 7.
- 390 • Calculate the fuel mass and VTP mass as function of optimized rudder mass and wing span, using the OAD derived surrogate model, see Figure 4.
- Calculate the weighted sum, see Equation 4.

395 As a constraint, a maximum rudder deflection of  $\theta = 32$  degrees is applied. The limit value here is used as an illustrative value. In practice, the rudder cannot deflect to large angles because of control limitations. For the rudder design problem it reduces the possible rudder configurations. Without the maximum rudder deflection constraint some designs result in larger rudder deflection, this can be seen in Figure 5. The deflection is calculated as function of rudder root chord  $c_{rud}$  and wing span  $b$  by using the AMLoad derived surrogate model (see 400 Figure 5).

The optimization problem formulation that was introduced in the previous section in Equation 2 is now filled in as follows:

$$\begin{aligned} \min_{b, c_{rud}} f_{obj} = & \quad w_1 * m_{VTP}(b, m_{rud}(c_{rud}, F_{rud}(c_{rud}, b))) + \dots \\ & \quad w_2 * m_{fuel}(b, m_{rud}(c_{rud}, F_{rud}(c_{rud}, b))) \quad (5) \\ \text{subject to:} & \quad \theta_{rud}(b, c_{rud}) \leq 32 \end{aligned}$$



405 The optimization has been performed in MATLAB using a sequential quadratic programming (SQP) method. The necessary optimization iterations are shown in Figure 11. Different weight combinations  $(w_1, w_2)$  have been applied. A larger value of  $w_1$  results in a lower VTP mass and in a larger fuel mass. Furthermore, the computational effort measured in number of optimization iterations differs.

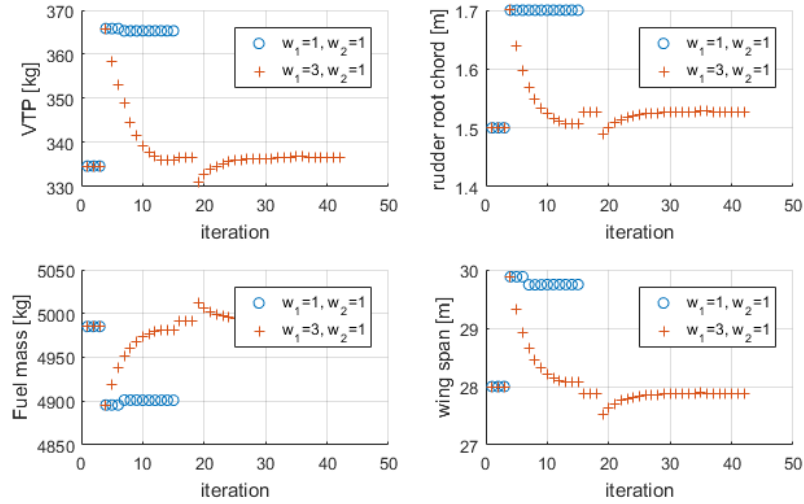

Figure 11: Results of the nested optimization approach. Optimization iterations (using SQP) with objectives (left) and design parameters (right) and two weight values.

410 Table 1 shows the SQP optimization results with varying weight values  $w_1$  from 1 to 8, while  $w_2 = 1$ . The optimized design varies from a large wing span with a low fuel mass and a relatively high VTP mass, to a small wing span with a higher fuel mass and lower VTP mass.

Weight value $w_1$	rudder root chord [m]	wing span [m]	VTP mass [kg]	Fuel mass [kg]	weighted objective $f_{obj}$
1	1.7	29.7	365.3	4901.0	5266.3
2	1.7	29.7	365.3	4901.0	5631.6
3	1.5	27.9	336.5	4992.5	6002.0
4	1.5	27.8	335.1	4997.6	6338.1
5	1.5	27.6	332.5	5009.3	6672.0
6	1.4	26.3	318.4	5092.8	7003.0
7	1.4	26.0	315.3	5112.8	7319.9
8	1.3	25.0	305.1	5189.1	7629.7

Table 1: SQP optima, with varying weight value  $w_1$  (with  $w_2 = 1$ ).

415 In case the wing span increases, the rudder root chord increases as well. This effect is enforced by the optimization constraint function: a large wing

span increases both the rudder force and deflection. If the deflection exceeds the deflection limit, the rudder chord needs to be enlarged, in order to enable the yaw moment compensation with a smaller rudder deflection.

420 Three calculated optima that are listed in Table 1 have been selected to be evaluated by the OAD capability. The optimized designs correspond to those with weight parameter  $w_1$  values 1,3 and 6. The results of these verified designs are listed in Table 2.

rudder root chord [m]	wing span [m]	VTP mass [kg] (surrogate prediction)	VTP mass [kg] (OAD calculation)	Fuel mass [kg] (surrogate prediction)	Fuel mass [kg] (OAD calculation)
1.4	26.3	318.4	318.3721	5092.8	5093.0
1.5	27.9	336.5	336.4851	4992.5	4994.0
1.7	29.7	365.3	365.328	4901.0	4901.0

Table 2: OAD evaluation of selection of optimization results

The surrogate model predictions are very close to the corresponding OAD evaluations. This result is in line with the low prediction errors that were previously observed in Figure 4.

425 The OAD tool has the possibility to plot the designs that have been evaluated by the tool. Therefore, the results of the three evaluated designs together with a reference design are shown in Figure 12 and Figure 13. The reference aircraft configuration in this case has a wing span of 27.18 [m] and a rudder root chord of 1.4651 [m].

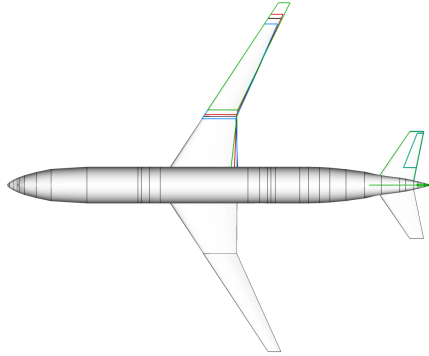

Figure 12: Wing planform comparisons of optimal designs: 1-blue, 2-red, 3-green (with increasing wing span) versus the baseline configuration (black).

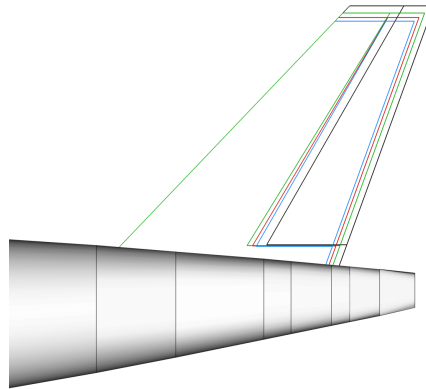

Figure 13: Vertical Tail Mass (VTP) comparisons of optimal designs: 1-blue, 2-red, 3-green (with increasing wing span) versus the baseline configuration (black).

## 5. MLO process via concept of Analytical Target Cascading (ATC)

The present section builds on the work reported in [1]. In that work the optimization was carried out all-in-one, in the present work the optimization for each disciplinary tool is carried out in a separate but coupled manner. The result of each optimized discipline is combined to arrive at an overall optimal design.

Various approaches can be followed to deal with the aircraft rudder multi-level optimization (MLO) use case. In the past decades, many methodologies have been investigated for MLO approaches in engineering problems. For example, overviews can be found in the PhD dissertation of De Wit [16], the overview of Balling and Sobieski [17] and the survey of Martins and Lambe [18].

In essence, an MLO problem consists of a hierarchy of individual but coupled optimization problems. In contrast, in traditional (single-level) optimization the hierarchical (multi-level) nature of the underlying design problem is not explicitly accounted for in the optimization problem formulation.

MLO approaches typically consist of four sequential steps. First, a hierarchy is identified in the considered system and/or design problem. Second, a decomposition (splitting) technique has to be defined based on the coupling characteristics. Third, a coordination strategy is defined. This involves setting up a procedure (i.e. define the rules) for communication between the decomposed but coupled subproblems. Finally, a job scheduling procedure is defined to have the sub problems communicate in the right sequence and corresponding to the computer architecture (e.g. sequential, parallel, or distributed).

A hierarchy can be naturally present in the process flow, e.g. along disciplines, departments or subcontractors that are involved in the design process. A hierarchy may also be introduced via e.g. a problem matrix [19] (also known as Functional Dependence Table [20]). In the present study of the aircraft rudder MLO use case the hierarchy is identified along the current process flow, in accordance with the hierarchy of the considered systems. An air framer designs an overall aircraft and subcontracts the rudder design. At (global) aircraft level design variables are set, e.g. wing span. At local level the rudder design variables are set, e.g. based on planform specifications, applied forces, manufacturing costs and available manufacturing material. Figure 14 shows an abstract representation of the levels present in the current design case.

In Figure 14 the global level calculations are carried out with an "expected" rudder mass and chord. Furthermore, forces applied to the rudder are calculated at global level. These three values are so-called "target" values ( $\mathbf{T}$ ). Hence, values the local level has to meet. These "target" values are send to the local level. At local level computations are carried out to meet the "target" values. Because the targets are rigid in Figure 14, the local level has the option of communicating back "responses" ( $\mathbf{R}$ ) that are in agreement with the targets; i.e. "come up with a rudder design that fulfills the expectations at global level and meets all requirements at local level". In case all requirements for the targets that have been set cannot be met at local level, an inconsistency is measured between targets and responses. The inconsistency is measured with

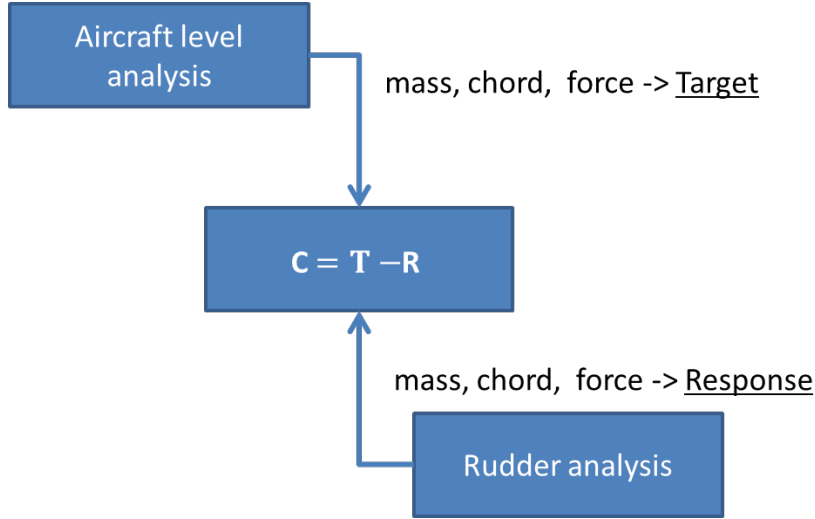

Figure 14: Introducing consistency constraints according to the ATC approach in a coupled MLO problem.

the consistency ( $\mathbf{C}$ ) constraint functions.

The consistency constraints can be evaluated on the global level, the local level, or at both levels. In our case the consistency constraints are evaluated at both levels. Therefore, each target variable has a "copy" at the local level and each response variable has a "copy" at the global level. In addition, consistency is now measured at global and at local level. Figure 15 depicts the decomposed optimization problem with the consistency constraints (both on global and local level).

Once consistency constraints have been formulated they are decomposed via a strong (equal) or weak (relaxed) formulation [21]. Both choices have their advantage or disadvantage. A strong formulation usually involves computing sensitivity of the individual optimization problems with respect to changes to the coupling or adding variables to calculate how the individual optimization problem reacts on external changes (changes due to the coupling). A weak formulation involves an additional approach to relax the consistency constraints e.g. by a penalty as function of the constraint deviations. In the present paper a choice was made to relax the consistency constraints to avoid additional programming steps that are necessary to implement a strong (equal) formulation.

To apply the technique of Analytical Target Cascading (ATC) the consistency constraints are relaxed via a so-called Augmented Lagrangian Penalty function [22]. This function is expressed as a function of the consistency:  $\pi(\mathbf{C})$ . The relaxed consistency constraints are then mathematically expressed as:

$$\pi(\mathbf{C}) = \mathbf{v}^T \mathbf{C} + \|\mathbf{w} \circ \mathbf{C}\|_2^2. \quad (6)$$

The  $\circ$  symbol is used to denote a term-by-term multiplication of vectors.

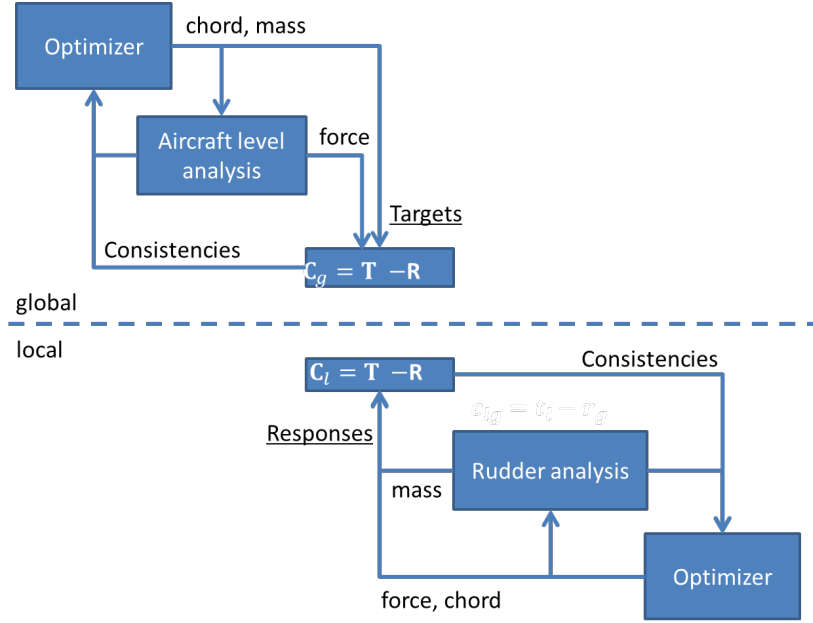

Figure 15: Decoupled aircraft level and rudder level optimization in ATC based MLO.

495 Two additional parameters are applied to derive a penalty function of the consistency violations (inconsistencies): the Lagrange multipliers  $\mathbf{v}$  and the penalty parameters  $\mathbf{w}$ . To determine values for these parameters a coordination strategy is necessary that is explained hereafter.

Initial values for the penalty parameters are set based on user experience. Alternatively, initial values can be calculated by evaluating the initial gap in consistency ( $\mathbf{C} \neq \mathbf{0}$ ). This can be accomplished by running each optimization problem using a very small penalty parameter. Each optimization problem in the hierarchy will then search for an optimal solution without considering the consistency with other problems in the hierarchy. This is explained in the work of Tosserams *et al.* [23]. In this work an initial guess for each penalty parameter is used as explained hereafter.

To achieve convergence of the relaxed global-local problem, the Lagrange multipliers are updated via:

$$\mathbf{v}^{k+1} = \mathbf{v}^k + 2\mathbf{w}^k \circ \mathbf{w}^k \circ \mathbf{C}^k \quad (7)$$

and the penalty parameters by:

$$\mathbf{w}^{k+1} = \beta \mathbf{w}^k \quad (8)$$

where  $\beta \geq 1$ , typically chosen between 2 and 3, see [22]. The  $k$  stands for the iteration number of updating the penalty parameters. These parameters are updated until the change in objective function values ( $f_{..}$ ) of global and local

level have become sufficiently small. Sufficiently small is in this case expressed by threshold  $\tau_{ATC}$  that is computed via:

$$\left\| (f_g + f_l)^k - (f_g + f_l)^{k-1} \right\|_{inf} \leq \tau_{ATC} \quad (9)$$

The entire optimization process (covering global and local) is finished when in addition to the change in objective function values (Equation 9) the change in consistency has become sufficiently small. This is mathematically expressed as:

$$\left\| \mathbf{C}^{k..} - \mathbf{C}^{k-1..} \right\|_{inf} \leq \tau \quad (10)$$

Typically,  $\tau_{ATC}$  is chosen as:

$$\tau_{ATC} = \frac{\tau}{10}. \quad (11)$$

Finally, a job scheduling procedure is defined. Here, a sequential solution process is chosen. First the global optimization problem is solved (with initial response values). Second, the targets from the global system are communicated to the local system and the local system is optimized, see the inner loops of Figure 16.

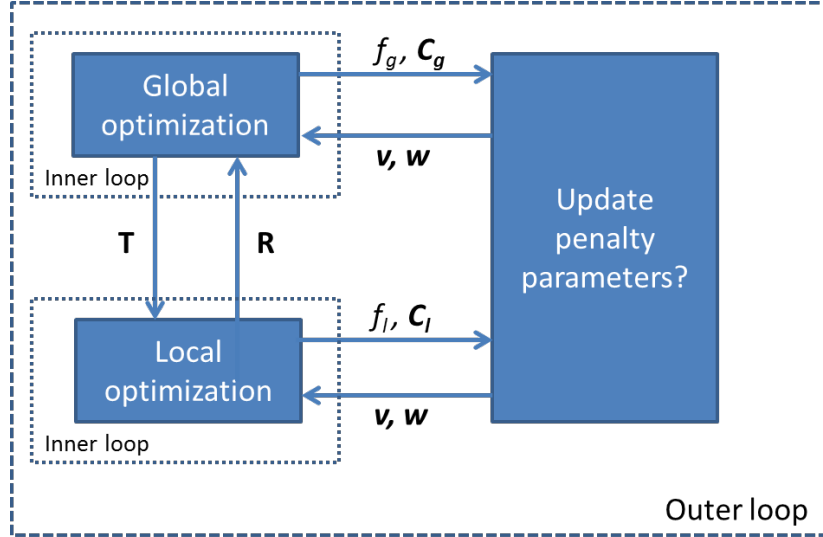

Figure 16: Sequential update process of the subsystems optimizations.

Third, a check for updating the Lagrange multipliers and penalty parameters is done, see the outer loop of Figure 16. The responses from local level are communicated to the global system. This procedure is then repeated until the change in (in)consistencies  $\mathbf{C}$  has become sufficiently small, see Equation 10.

Applying the ATC approach (as described above) to the rudder optimization problem that was mathematically expressed in Equation 2 one obtains the

following problem decomposition. The global optimization problem is expressed as:

$$\min_{b, \mathbf{T}} \quad f_g(b, \mathbf{T}) + \pi(\mathbf{C}_g) \quad (12)$$

$$\text{subjected to:} \quad g(\mathbf{R}) \leq \mathbf{0} \quad (13)$$

$$\text{bounded by:} \quad \underline{b}, \underline{\mathbf{T}} \leq b, \mathbf{T} \leq \bar{b}, \bar{\mathbf{T}} \quad (14)$$

The local optimization problem is expressed as:

$$\min_{\mathbf{R}} \quad f_l(\mathbf{R}) + \pi(\mathbf{C}_l)$$

$$\text{bounded by:} \quad \underline{\mathbf{R}} \leq \mathbf{R} \leq \bar{\mathbf{R}}$$

515 With  $b$  the wing span,  $\mathbf{T}$  the target values of the coupling variables (rudder chord  $c_{rud}$ , rudder mass  $m_{rud}$  and rudder force  $F_{rud}$ ),  $\mathbf{R}$  the (local level) responses of the coupling variables and  $\mathbf{C}_g$  and  $\mathbf{C}_l$  the consistencies on global and local level.  $\pi$  is the penalty function as described above and  $f_g$  and  $f_l$  are the global and local objective functions.

520 The functions  $f_g$ ,  $g$ , and  $f_l$  have been previously introduced. Using the target and response variables these equations are mathematically expressed via:

$$\begin{aligned} f_g(c_{rud}, b) &= & f_{obj} &= w_1 * m_{VTP} + w_2 * m_{fuel} \\ g(c_{rud}, b) &= & \theta - 32 &\leq 0 \\ f_l(c_{rud}, F_{rud}) &= & m_{rudder} \end{aligned} \quad (15)$$

Furthermore, a rudder force calculation is used:  $F_{rud} = f_{AML}$  and rudder (scaled) mass:  $m_{rudder} = h(c_{rud}, F_{rud})$ . The latter is scaled because the exact mass output of the rudder was not available, see subsection 4.1.

525 The global and local optimization problems have been implemented in MATLAB and solved via the ATC procedure. Both the global and local optimizations have been performed with a sequential quadratic programming (SQP) method, using finite difference approximation of the derivatives. The iteration history of the coupling variables during the ATC process are shown in Figure 17, Figure 18 and Figure 19.

530 The iteration history of the outer loop is reflected in figures 17, 18 and 19. These figures show the history of global and local optimal rudder chord  $c_{rud}$ , rudder force  $F_{rud}$  and rudder mass  $m_{rud}$ . The initial differences between the targets (in the figures denoted " + ") and responses (in the figures denoted " o ") are relatively large. Hence, when left to itself the global optimum value for VTP weight and fuel mass corresponds to a rudder chord, rudder force and rudder mass that is different from the optimum rudder weight.

540 The augmented Lagrangian penalty function pushes the global and local level objective and constraint functions to move the target values and response values closer to an agreement (consistency). After 6 cycles of inner and outer loop, consistency is within acceptable tolerance ( $\tau \leq 5e - 3$ ) and a corresponding



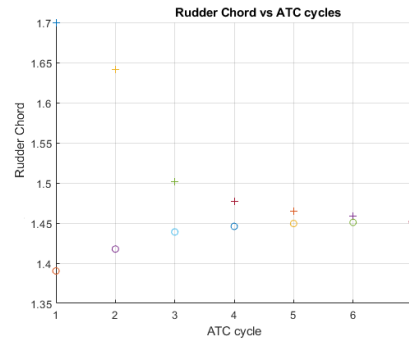

Figure 17: Iteration history of the ATC algorithm. Values of computed rudder chord versus number of ATC cycles. The "+" symbols represent values calculated at global level. The "o" symbols represent values calculated at local level.

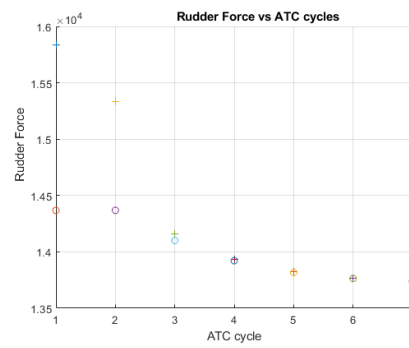

Figure 18: Iteration history of the ATC algorithm. Values of computed rudder force versus number of ATC cycles. The "+" symbols represent values calculated at global level. The "o" symbols represent values calculated at local level.

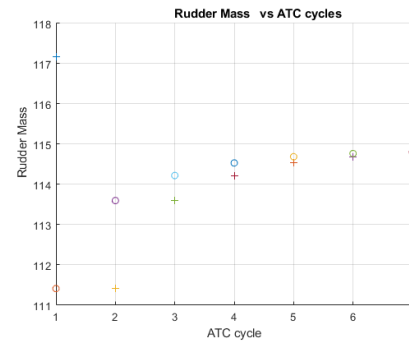

Figure 19: Iteration history of the ATC algorithm. Values of computed rudder mass versus number of ATC cycles. The "+" symbols represent values calculated at global level. The "o" symbols represent values calculated at local level.

optimum solution for global and local objective function has been found. This global and local optimum is feasible for both global and local optimization problem. Compared to the nested optimization (see Figure 11) this results in a smaller number of data exchanges between global and local level.

The iteration history of the inner loop is reflected in Figure 20 for global design variable wing span  $b$ , in Figure 21 for the global value VTP mass ( $m_{VTP}$ ) and in Figure 22 for global value fuel mass ( $m_{fuel}$ ).

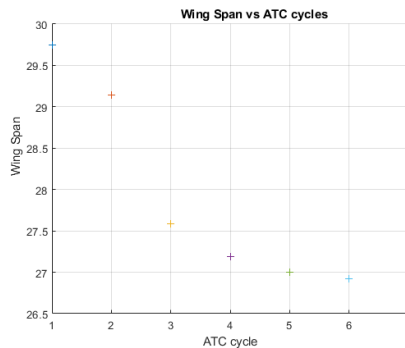

Figure 20: Wing Span versus ATC.

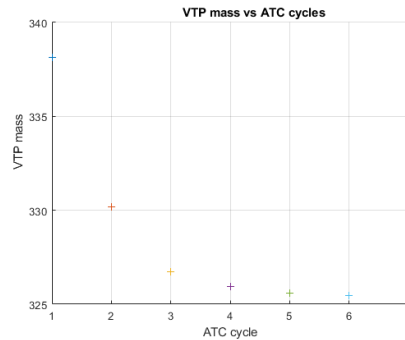

Figure 21: VTP mass versus ATC cycles.

The ATC parameters were tuned to get a consistent solution between global and local optimization as quickly as possible starting from an arbitrary feasible design. Parameters that can be tuned are the initial penalty parameters  $\mathbf{v}^k$ , the consistency tolerance  $\tau$  and penalty update parameter  $\beta$ . In the present setting, initial penalty parameters were set to  $\mathbf{v}^k = 10$ , the consistency tolerance to  $\tau = 5e - 3$  and penalty update parameter to  $\beta = 3$ .

In case the initial value of  $\mathbf{v}^k$  is set high, the global and local optimization problem have little room to adjust the target or response value to a value other than the initial one. Hence, little design freedom is given to reach consistency. The consistency tolerance  $\tau$  is a measure how well the target and response at the

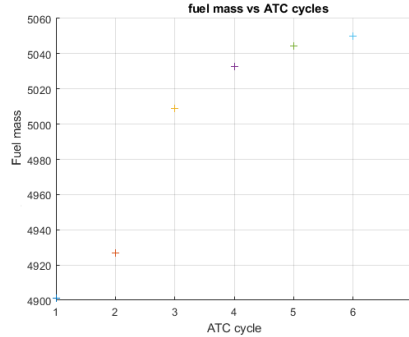

Figure 22: Fuel Mass versus ATC cycles.

interface between global and local meet. A loose setting may cause premature  
 560 convergence of global and local level arriving at a non-optimal overall design.  
 Likewise, a tight setting may cause endless exchange of targets and responses  
 between global and local level while the overall design doesn't change. The  
 penalty update parameter  $\beta$  is a setting to scale the penalty parameters. The  
 higher the value of  $\beta$ , the faster global and local target and response values  
 565 will meet. Hence, less design freedom is given to the individual optimization  
 problems. Contrary, the lower the value of  $\beta$ , the more design freedom is given  
 at the expense of more exchange of target and response values between the  
 global and the local level.

The iteration history shown in Figures 20, 21 and 22 converges to the op-  
 570 timum that was found with the nested approach. However, for the nested ap-  
 proach weight values  $w_1 = 6$  and  $w_2 = 1$  were chosen. The ATC approach  
 converges to this optimum with weight values  $w_1 = 1$  and  $w_2 = 1$ . This is  
 because in the ATC optimization the objectives were normalized to unity and  
 in the nested optimization they were not. By changing weight values in the  
 575 MLO formulation the optima that were found with the nested approach can be  
 reproduced as well. This is shown in Table 3.

rudder root chord [m]	wing span [m]	rudder mass [kg]	VTP mass [kg]	Fuel mass [kg]	ATC iterations	weights	$\tau$
1.35	25.7	106	313	5134	12	$w_1 = 1, w_2 = 1$	6e-4
1.39	26.3	110	318	5092	13	$w_1 = 1, w_2 = 10$	6e-4
1.42	26.6	113	322	5072	14	$w_1 = 1, w_2 = 100$	5e-4
1.45	26.9	115	326	5053	14	$w_1 = 1, w_2 = 1e3$	1e-3
1.48	27.2	117	328	5032	15	$w_1 = 1, w_2 = 1e4$	7e-4
1.50	27.5	119	332	5013	15	$w_1 = 1, w_2 = 1e5$	4e-4
1.68	29.5	143	363	4909	19	$w_1 = 1, w_2 = 1e8$	6e-4
1.70	29.7	143	364	4901	13	$w_1 = 1, w_2 = 7e7$	9e-4

Table 3: ATC MLO optimization results

In Table 3 the results are listed for various weights ( $w_1$  and  $w_2$ ) settings  
 in the objective function  $f_{obj}$  to reproduce the optima found with the nested  
 optimization approach. The ATC settings were set at default settings with

580 initial ( $k=1$ ) penalty weight  $\mathbf{v}^1 = 1$ , consistency setting  $\tau_{atc} \leq 1e-3$  and  $\beta = 3$ .

For ATC to work efficiently, all design variables and optimization functions need to be scaled to unity. This was not done for the nested optimization. Therefore, the difference between weights ( $w_1, w_2$ ) can partly be accounted for by looking at the scaling of the optimization functions. However, to arrive  
585 at designs that find rudder root chord 1.7 and wing span 29.7 optimal, the weight  $w_2$  needs to be significantly increased. This is due to the additional minimization of the rudder mass in addition to minimizing the VTP mass. The nested approach does not separately minimize the rudder mass. As a result, the MLO problem formulation finds a lower mass and lower rudder root chord.

590 From this MLO exercise it can be seen that individual optimizations on local and global level may provide conflicting design results. A strategy, such as ATC is needed that integrates both optimizations and synchronizes the results, taking into account the mutual inter-dependencies. Due to the division in inner and outer loops the number of exchanges between global and local level is smaller  
595 than if a nested approach would be applied.

A next step to show the possibilities of this MLO approach is to extend the MLO use case with additional levels. For example the VTP sizing could be placed below the overall aircraft sizing. In this case the rudder optimization would be placed below the VTP sizing as a third level. At global level total fuel  
600 mass could be an objective, whereas at the first level the VTP sizing is carried out to minimize structural mass and/or cost. At the lowest level sizing of the hinges and rudder internals could be optimized via HDOT.

The current MLO case could be further extended with additional disciplines. E.g. sizing of the wing planform as a second discipline where aerodynamic  
605 considerations are taken into account below the global OAD computations. In this context HDOT could be applied as well to contribute to the design of the wing moveables. Furthermore, a power plant discipline could be added to analyze fuel flow as a function of thrust requirement due to wing and VTP sizing in the neighboring disciplines.

## 610 6. Conclusions

A multi-level optimization approach to a coupled aircraft rudder design problem has been presented. An MLO method based on Analytical Target Cascading is used for decoupling the optimization problem into an aircraft (global) level optimization problem and rudder (local) level optimization problem. Both  
615 problems are solved separately, while enforcing the couplings by consistency constraints. The level of consistency is checked after each global and local optimization in an iterative process. As a starting point (reference) the same problem has been solved using a nested optimization approach as well. The ATC method and nested optimization method arrive at the same design optima. However,  
620 in the case of ATC the number of communication events between the global and the local level becomes smaller than with the nested approach, in which the local optimization is part of the global objective function. Limiting the amount of interaction is needed in order to create an efficient collaboration between the aircraft OEM (performing the global optimization) and the supplier  
625 (performing the local optimization).

The aircraft rudder MLO use case is illustrated by applying surrogate models that were derived from aircraft and rudder design analysis competences available from the AGILE project. The surrogate models provide an efficient approach for running the MLO. Additionally, they have been shared through  
630 the Surrogate Model Repository (SMR). The SMR – also developed in AGILE – facilitates a knowledge-enabled approach for deployment of the surrogate models, e.g. in the context of MLO. It stores meta information with the surrogate models and provides an export to the generic MDO workflow specification format CMDOWS, from which an extended design structure matrix (XDSM) can  
635 be generated and MDO workflows can be realized.

It has been illustrated that applying MLO (e.g. using surrogate models) provides insight into the coupled design problem both for the OEM and for the supplier. Using MLO the OEM and supplier are able to significantly reduce the development time of an aircraft subsystem. Automation of the communication  
640 reduces the chance of miscommunications and corresponding rework. In addition, the surrogate models that are part of MLO could be used to shield the intellectual property (IP) of both OEM and supplier and could provide flexibility when performing conceptual design. This would allow for a better collaboration in situations where contracts have not been signed and IP issues  
645 can be sensitive.

In a next step, the design case could be extended to additional levels. A three level hierarchy in which the OAD, VTP sizing and rudder sizing form the levels is a first extension of the two level case presented here. Such an extension demonstrates the interaction between levels in a design hierarchy.  
650 Alternatively, an additional discipline could be added. For example, sizing of the wing planform involving an aerodynamic discipline could be added and/or a power plant discipline to demonstrate the interaction between disciplines in the design process. The MLO approach is not restricted to a two-level design problem as presented in this work but can be easily extended to much larger

655 and more complex hierarchies.

## Acknowledgements

The research presented in this paper has been performed in the framework of the AGILE project (Aircraft 3rd Generation MDO for Innovative Collaboration of Heterogeneous Teams of Experts) and has received funding from the European Union Horizon 2020 Programme (H2020-MG-2014-2015) under grant agreement no. 636202. The authors are grateful to the partners of the AGILE Consortium for their contribution and feedback.

## References

- [1] W. Lammen, B. de Wit, J. Vankan, H. Timmermans, T. van der Laan, P. Ciampa, Collaborative design of aircraft systems - multi-level optimization of an aircraft rudder, in: Aerospace Europe 6th CEAS Conference, 898, CEAS Council of European Aerospace Societies, 2017. doi: NLR-TP-2017-370.
- [2] AGILE consortium, Agile website (2017).  
URL <http://www.agile-project.eu>
- [3] The AGILE Paradigm: the next generation of collaborative MDO, AIAA, 2017.
- [4] FAA, FAR Part 25 Section 25.147 (2017).  
URL <http://www.far.gov>
- [5] H. Timmermans, B. Prananta, Aeroelastic challenges in the aircraft design process, in: READ and SCAD conference, 2016.
- [6] A. Kulkarni, R. van Dijk, T. van den Berg, G. L. Rocca, A knowledge based engineering tool to support front-loading and multi-disciplinary design optimization of the fin-rudder interface, in: Aerospace Europe 6th CEAS Conference.
- [7] I. van Gent, B. Aigner, B. Beijer, J. Jepsen, G. L. Rocca, Knowledge architecture supporting the next generation of mdo in the agile paradigm, in: PIAS Agile, Elsevier, 2018, p. TBD.
- [8] D. Böhnke, B. Nagel, V. Gollnick, An approach to multi-fidelity in conceptual aircraft design in distributed design environments, in: 32nd IEEE Aerospace Conference, Big Sky, 2011.
- [9] P. Ciampa, T. Zill, B. Nagel, A hierarchical aeroelastic engine for the preliminary design and optimization of the flexible aircraft, in: 54th AIAA/ASME/ASCE/AHS/ASC Structures, Structural Dynamics, and Materials Conference, AIAA, 2013.

- [10] W. Vankan, W. Lammen, R. Maas, Meta-modeling and multi-objective optimization in aircraft design, in: E. Kessler, M. Guenov (Eds.), *Advances in collaborative civil aeronautical multidisciplinary design optimization*. Progress in Astronautics and Aeronautics, Vol. 233, American Institute of Aeronautics and Astronautics, 2010, Ch. 6.
- 695 [11] W. Lammen, P. Kupijai, Kickenweitz, T. Laudan, Integrate engine manufacturer’s knowledge into the preliminary aircraft sizing process, *Aircraft Engineering and Aerospace Technology: An International Journal* 86 (2014) 336–344.
- 700 [12] E. Baalbergen, E. Moerland, W. Lammen, P. Ciampa, Methods supporting the efficient collaborative design of future aircraft, in: *Aerospace Europe 6th CEAS Conference*, CEAS, 2017.
- [13] E. Moerland, P. Ciampa, S. Zur, E. Baalbergen, R.D’Ippolito, R. Lombardi, Collaborative architecture supporting the next generation of mdo within the agile paradigm, in: *PIAS Agile*, Elsevier, 2018, Ch. 2.
- 705 [14] A. Lambe, J. Martins, Extensions to the design structure matrix for the description of multidisciplinary design, analysis, and optimization processes, *Structural and Multidisciplinary Optimization* 46 (2012) 273–284.
- [15] Wikipedia, Sankey diagram (2017).  
 710 URL [https://en.wikipedia.org/wiki/Sankey\\_diagram](https://en.wikipedia.org/wiki/Sankey_diagram)
- [16] A. de Wit, A unified approach towards decomposition and coordination for multilevel optimization, Ph.D. thesis, Delft University of Technology (2009).
- [17] R. Balling, J. Sobieszczanski-Sobieski, Optimization of coupled systems: A critical overview of approaches, *AIAA Journal* 34 (1996) 6–17.
- 715 [18] J. Martins, A. Lambe, Multidisciplinary design optimization: A survey of architectures, *AIAA Journal* 51 (2013) 2049–2075.
- [19] J. Barthelemy, Engineering design applications of multilevel optimization methods, *Computer Aided Optimum Design of Structures: Applications* (1989) 113–122.
- 720 [20] T. Wagner, A general decomposition methodology for optimal system design, Ph.D. thesis, The University of Michigan (1993).
- [21] A. de Wit, F. van Keulen, Overview of methods for multi-level and/or multi-disciplinary optimization, in: *51st AIAA/ASME/ASCE/AHS/ASC Structures, Structural Dynamics, and Materials Conference*, AIAA, 2010.
- 725 [22] S. Tosserams, L. Etman, P. Papalambros, J. Rooda, An augmented lagrangian relaxation for analytical target cascading, *Structural and Multidisciplinary Optimization* 31 (2006) 176–189.



- 730 [23] S. Tosserams, L. Etman, J. Rooda, Multi-modality in augmented lagrangian coordination for distributed optimal design, *Structural and Multidisciplinary Optimization* 40 (2010) 329–352.

This page is intentionally left blank.



**NLR**

Anthony Fokkerweg 2  
1059 CM Amsterdam, The Netherlands  
p) +31 88 511 3113  
e) [info@nlr.nl](mailto:info@nlr.nl) i) [www.nlr.nl](http://www.nlr.nl)