

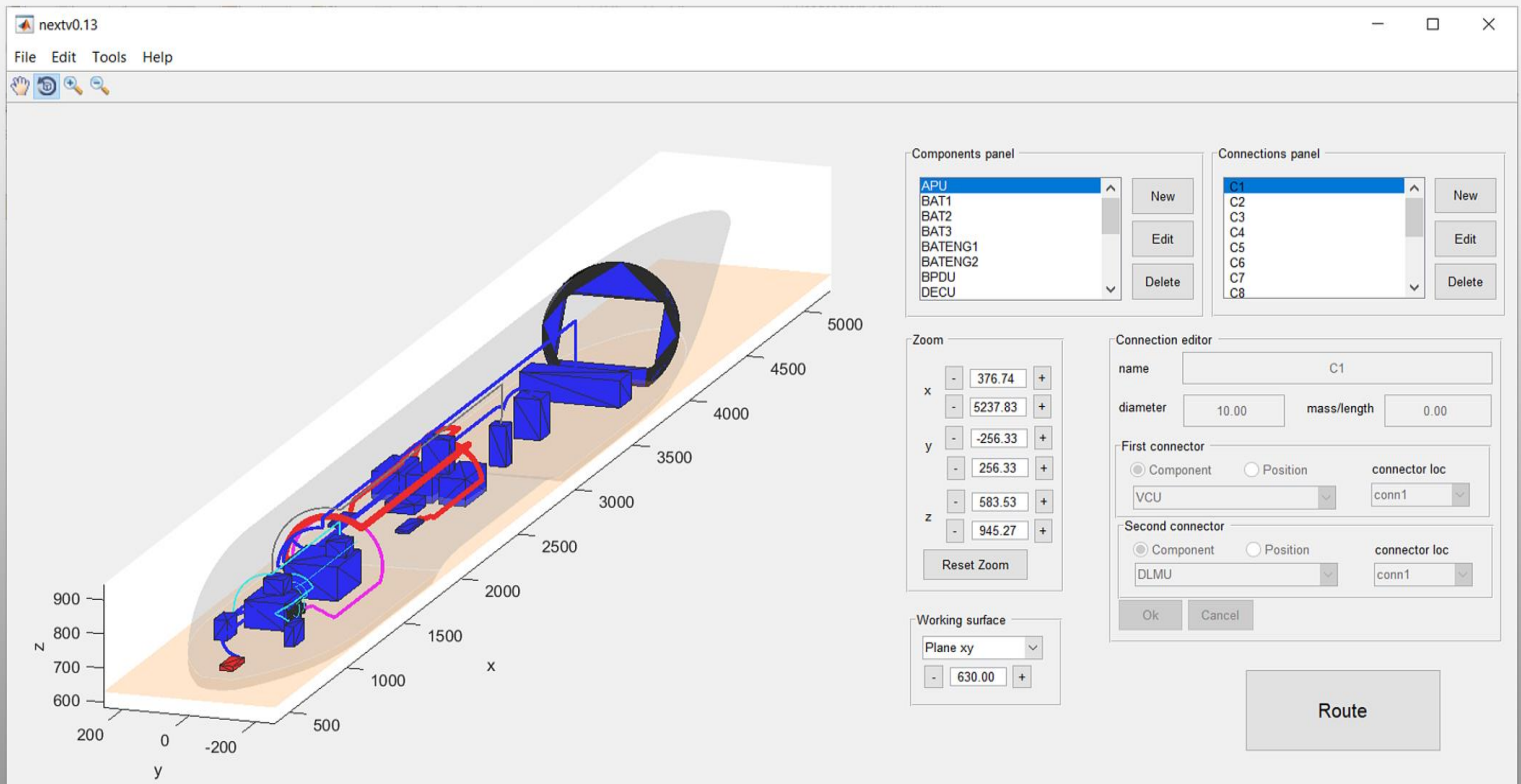

Optimization tool for equipment placement and routing in more electric aircraft

CUSTOMER: Royal Netherlands Aerospace Centre



Optimization tool for equipment placement and routing in more electric aircraft

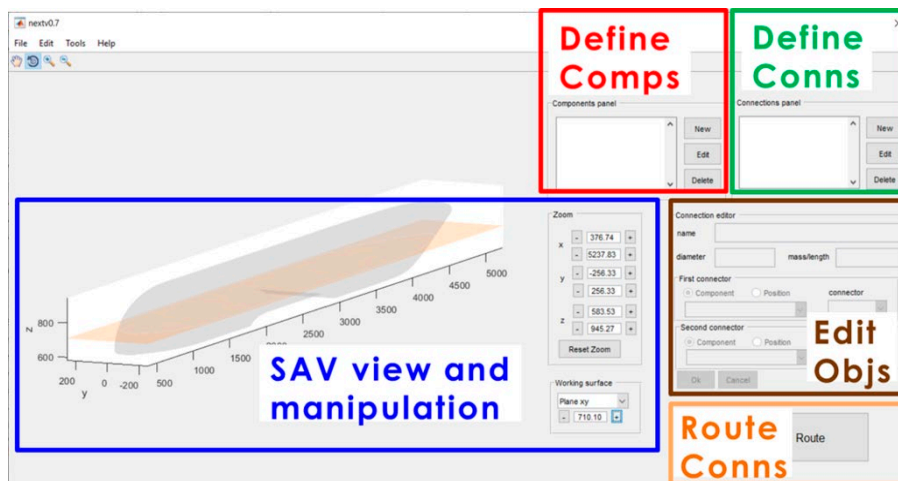

Illustration of the main GUI of the NEXT software tool with the main functional panels are indicated by colours

Problem area

With the development of more electric, hybrid electric and fully electric aircraft, the number of electric components on board aircraft and their power consumption is increasing. The optimized placement, arrangement and interconnection of these electric components give rise to new challenges. The higher operating temperatures and accessibility for maintenance may further complicate the feasible arrangement of all the required electric components. And besides the placement of all these components also their feasible interconnectivity by electric wires and harnesses shall be ensured. Moreover, during the aircraft design this arrangement of components shall be optimized concurrently with the arrangement of other items like the airframe structure, flight controls and actuators, fuel tanks and so forth.

REPORT NUMBER
NLR-TP-2020-011

AUTHOR(S)
W.J. Vankan
R. Maas
S.M. Moghadasi

REPORT CLASSIFICATION
UNCLASSIFIED

DATE
February 2020

KNOWLEDGE AREA(S)
Aerospace Collaborative
Engineering and Design

DESCRIPTOR(S)
equipment
space allocation
graph theory
electric system
harnesses

Description of work

This paper presents a methodology for optimizing the electric system arrangement, where the modelling and optimization methods are based on graph theory. The graph based modelling and its implementation in a dedicated software tool allows for efficient representation of the conceptual design CAD data of aircraft and systems geometry. This software tool (NEXT: Novel Equipment placement and routing eXploration Tool) considers the placement of components and automated routing of interconnections in arbitrary 3-dimensional (3D) installation spaces and includes efficient routing algorithms that rely on variants of the well-known Dijkstra's algorithm. The development of this software tool is focussed on the efficient integration with the CAD systems that are typically used in the industrial aircraft design processes.

Results and conclusions

It is demonstrated for a design case of a basic electric system installation in a scaled aircraft that both efficiency and flexibility are ensured in this CAD integration process. The focus of this paper is not on the actual detailed design of the considered electric system, but more to present the efficiency and flexibility of the interoperability with CAD and how the conceptual design CAD data can be exploited. It is demonstrated how the geometric CAD data of the fuselage geometry and the electric components can be directly imported in the NEXT tool. The calculation times for the optimized routings of the connections in this design case are about 3s per connection on a standard PC. This allows for quick design iterations that enable the evaluation and optimization of many different variations of the component placement in the Space Allocation Volume (SAV).

Applicability

The methodologies used for the automated placement of components and routing are very flexible and well-suited for other industrial applications like harnesses routing and design for whole aircraft, wings or engines. Also other types of system installations can be modelled and optimized in a similar way, including pneumatic and hydraulic systems or their combinations as commonly found in aircraft installations.

GENERAL NOTE

This report is based on a paper presented at the Aerospace Europe Conference - AEC2020, February 25-28, 2020, Bordeaux, France.

NLR

Anthony Fokkerweg 2

1059 CM Amsterdam, The Netherlands

p) +31 88 511 3113

e) info@nlr.nl | www.nlr.nl



Dedicated to innovation in aerospace

NLR-TP-2020-011 | February 2020

Optimization tool for equipment placement and routing in more electric aircraft

CUSTOMER: Royal Netherlands Aerospace Centre

AUTHOR(S):

W.J. Vankan

NLR

R. Maas

NLR

S.M. Moghadasi

NLR

This report is based on a paper presented at the Aerospace Europe Conference - AEC2020, February 25-28, 2020, Bordeaux, France.

This publication has been refereed by the Advisory Committee AEROSPACE VEHICLES.

The contents of this report may be cited on condition that full credit is given to NLR and the author(s).

CUSTOMER	Royal Netherlands Aerospace Centre
CONTRACT NUMBER	-----
OWNER	NLR
DIVISION NLR	Aerospace Vehicles
DISTRIBUTION	Unlimited
CLASSIFICATION OF TITLE	UNCLASSIFIED

APPROVED BY:		Date
AUTHOR	W.J. Vankan	10-01-2020
REVIEWER	J. Kos	10-01-2020
MANAGING DEPARTMENT	A.A. ten Dam	20-01-2020

Contents

Abbreviations	4
1 Introduction	5
2 Methodology	6
3 Implementation	6
4 Simplified design case: scaled aircraft	8
5 Results	10
6 Conclusion	12
7 Acknowledgements	13
8 References	13

Abbreviations

ACRONYM	DESCRIPTION
BPDU	Battery Power Distribution Unit
CAD	Computer-aided design
DLMU	Data Link Management Unit
ECS	Environmental control system
EWIS	Electrical Wiring Interconnection System
IGES	Initial Graphics Exchange Specification
MATLAB	MATrix LABoratory
MEA	More electric aircraft
NEXT	Novel Equipment placement and routing eXploration Tool
NLR	Royal Netherlands Aerospace Centre
SAV	Space Allocation Volume
STL	STereolithography
VCU	Vehicle Control Unit
WIPS	Wing ice protection system

Optimization tool for equipment placement and routing in more electric aircraft

W.J. Vankan, R. Maas, M. Moghadasi

Royal Netherlands Aerospace Centre NLR, Amsterdam, the Netherlands; jos.vankan@nlr.nl

KEYWORDS: equipment, space allocation, graph theory, electric system, harnesses

ABSTRACT:

With the development of more-electric, hybrid-electric and fully-electric aircraft, the number of electric components in aircraft and their power consumption is increasing. The optimized placement, arrangement and interconnection of these electric components give rise to new challenges. This paper presents a methodology for optimizing the electric system arrangement, where the modelling and optimization methods are based on graph theory. The graph based modelling and its software implementation allows for efficient exploitation of conceptual design CAD data of aircraft and systems geometry. This software implementation considers the placement of components and automated routing of interconnections in arbitrary 3-dimensional installation spaces. The development of this tool is focussed on efficient integration with CAD systems that are typically used in industrial aircraft design processes. It can be applied to arbitrary installation volumes of full-scale aircraft, but also of scaled aircraft (e.g. used for scaled flight testing) where spatial limitations are even stricter.

1. INTRODUCTION

With the development of more electric, hybrid electric and fully electric aircraft, the number of electric components on board aircraft and their power consumption is increasing. More electric aircraft (MEA) are typically considered as aircraft with increased electrification of their non-propulsive systems [1],[2], whereas hybrid electric and fully electric aircraft are usually considered as aircraft with partial or full electrification of their propulsion system [3]. An example of large MEA is the Boeing 787, with nearly 1.5MW of installed electric power for its non-propulsive systems like environmental control system (ECS) and wing ice protection

system (WIPS) [4] (figure 1). Hybrid electric and fully electric (or all electric) aircraft for large commercial transport have not yet been developed. But small aircraft have recently been built like the 6-seat parallel hybrid Ampaire Electric EEL [5] with a 160kW electric motor, which first flew in 2019. A recent example of a small full electric aircraft is the Pipistrel Alpha Electro [6], a 2-seat trainer with about 60kW electric motor and 21 kWh Li-ion battery pack.

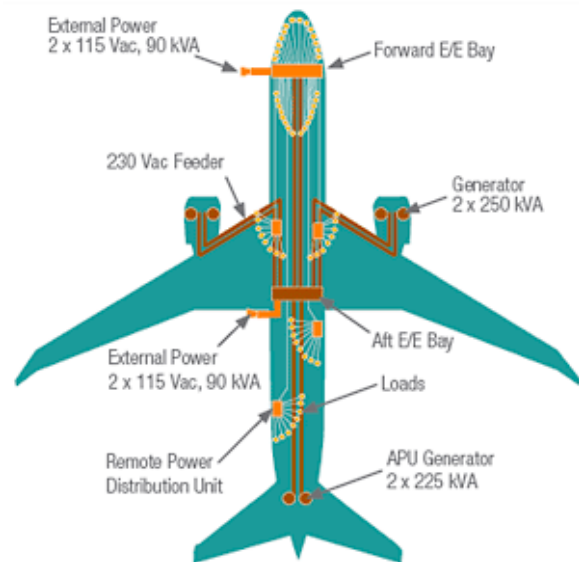

Figure 1: Illustration of the Boeing 787 MEA's main electrical system with nearly 1.5MW of installed electric power for its non-propulsive systems [4].

Current aircraft electrical systems already include many different components like generators, busses, transformers, rectifiers, inverters and various electric consumers, which are all interconnected by the so-called Electrical Wiring Interconnection System (EWIS). In large aircraft the EWIS is very extensive and complex. For example in the Airbus A380 it contains more than 500 km of cables, 100.000 wires and 40.000 connectors [7]. Besides EWIS complexity, also the space allocation of the many electric components has become an increasing challenge. In aircraft limited space is available for the systems installation and for ventilation

solutions. With the incorporation of more electric components with higher power, new challenges arise for the optimized arrangement and placement of these components. The higher operating temperatures of the electric components and their in-accessibility for maintenance may further complicate the feasible arrangement of all the required electric components. And besides the placement of all these components also their feasible interconnectivity by the EWIS shall be ensured. Moreover, during the aircraft design this arrangement of components shall be optimized concurrently with the arrangement of other items like the airframe structure, flight controls and actuators, fuel tanks and so forth. To address these challenges, efficient ways of developing flexible and integrated solutions for the layout of the electric system have been investigated in the present research project executed at NLR. This work builds upon previous work, in which optimization methodologies for the integrated equipment installation in aircraft engines were investigated [8].

2. METHODOLOGY

In the current project, new methodologies have been investigated aimed at optimizing the electric system arrangement by automated placement of components and routing of interconnections in 3-dimensional (3D) space. This optimization may take place early in the aircraft and system design process such that the components' space allocation still has sufficient degrees of freedom. But this requires a smooth integration of the system optimization into the conceptual design process, where geometries of the aircraft and systems are being defined in computer aided design (CAD) tools such as CATIA [9]. Efficient exchange between the CAD tools and the system optimization process is therefore pursued. The system optimization process shall allow for easy incorporation of conceptual design CAD data of aircraft and systems geometry. The system optimization process shall also support high flexibility in component placement and in the definition of the connectivity network. With the definition of the interconnections between components, automatic routing methods can be used to determine the best pathways of wires and harnesses. And for the efficient exchange

with CAD tools, the resulting optimized system arrangement shall be directly exported to CAD to allow for efficient conceptual design iterations.

The present study investigates methodologies for optimizing the electric system arrangement, where the modelling and optimization methods are based on graph theory. Graph based approaches for system installation problems have been previously investigated. For example machine-executed compilations of graph-based design languages that efficiently address topological and parametrical design problems, with application to aircraft cabin system design, are presented in [10]. Investigations of graph based routing algorithms accounting not only for total path length, but also for other factors that depend on local conditions in the routing space like installation aspects (clamps, insulation, thermal protection etc.) and segment bend radius of local curvature, are presented for example in [11].

3. IMPLEMENTATION

This paper presents the implementation of graph based optimization methodologies into an efficient software tool for system installation: NEXT (Novel Equipment placement and routing eXploration Tool). The focus for the efficiency of this tool is on the easy integration with CAD systems, such as CATIA, that are typically used in industrial aircraft design processes. In this way the tool shall support efficient design iterations in conceptual design phases where modifications in the electric system layout can be quickly optimized and exchanged with the aircraft level CAD models. This software tool has been implemented in MATLAB [12] and supports direct manipulation through tailored GUIs (figure 2).

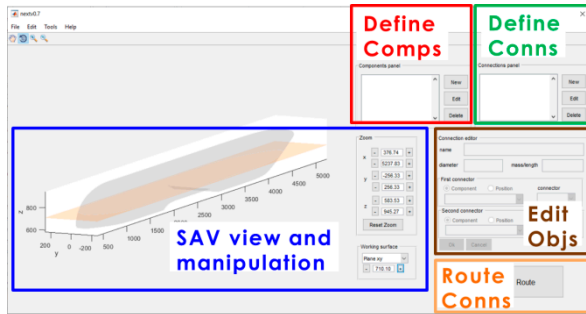

Figure 2: Illustration of the main GUI of the NEXT software tool. The main functional panels are indicated by colours: panel for 3D viewing, zooming and rotating the SAV (Space Allocation Volume) geometry (blue) (the specific SAV geometry shown is explained in Fig. 3); panel for definition of components (red); panel for definition of connections (green); panel for detailed editing components or connections (brown); panel for routing connections (orange).

The graph based modelling allows for efficient representation of the conceptual design CAD data of aircraft and systems geometry. This is achieved by 3D grid-based discretization of the considered items. One key item is the 3D volume in which the electric system shall be installed, such as the electronics or systems bays. This volume will be further referred to as the Space Allocation Volume (SAV). This SAV is created from the volume's 3D surrounding surface, typically represented as STereoLithography (STL) file that can be directly extracted from the conceptual aircraft CAD data (figure 3).

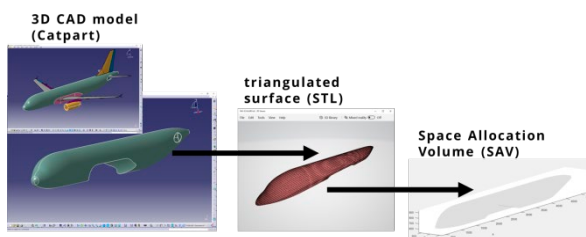

Figure 3: Illustration of the extraction of the SAV from CAD, shown here for a scaled aircraft fuselage interior. From the aircraft CAD model defined as CATIA Catpart (left) the SAV geometry is directly extracted as STL file (middle) and translated to the graph model of the SAV (right).

Other key items that are considered in the graph based modelling are the electric system components, like generators, converters etc. Similar to the SAV, these components are also created from their geometry's 3D surrounding

surface, also represented as STL file directly extracted from the conceptual electric system CAD data. In this way these components can be directly combined with the SAV into the graph. The positioning of the components in the SAV is simply done by assigning location and orientation vectors to the components. Besides location and orientation the components have several other attributes like connectors, mass and type. The connectors represent locations on the component surface where connections to other components are made. Also these connections can be directly extracted from the CAD data as 3D locations which can be imported into the graph as Initial Graphics Exchange Specification (IGES) files (figure 4).

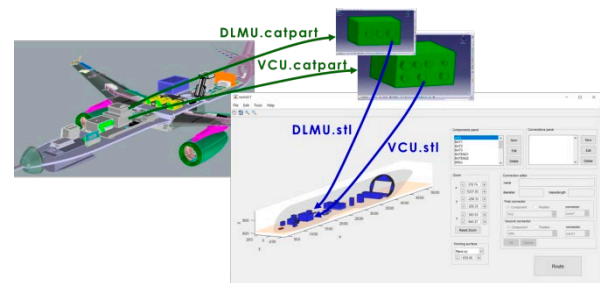
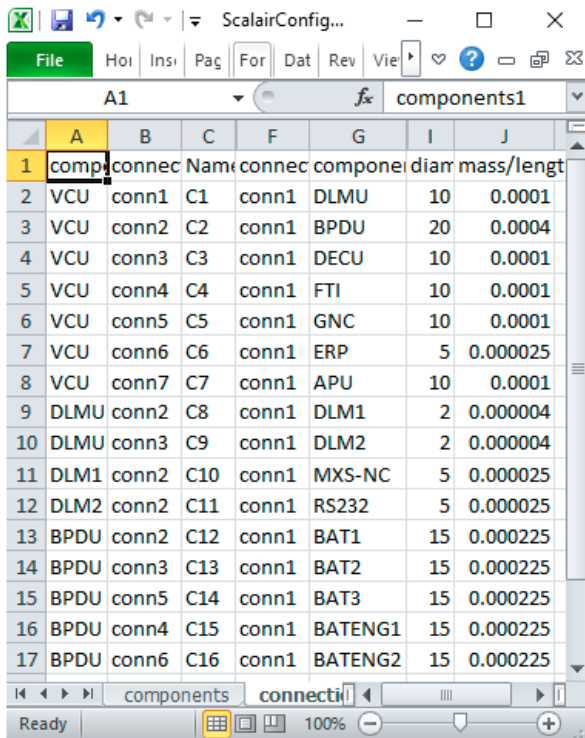

Figure 4: Illustration of the extraction of the components from CAD. From the aircraft's electric system CAD model (upper left), the components DLMU and VCU are extracted as CATIA Catparts (upper right) and directly translated to STL files that are imported into the NEXT tool (lower right).

The interconnections between the components are defined as pairs of connectors and other attributes like name, diameter and mass of the connection. The connections can be defined in an EXCEL table, as shown in the example in table 1.



	A	B	C	F	G	I	J
1	comp	connec	Conn	conn	compon	diam	mass/length
2	VCU	conn1	C1	conn1	DLMU	10	0.0001
3	VCU	conn2	C2	conn1	BPDU	20	0.0004
4	VCU	conn3	C3	conn1	DECU	10	0.0001
5	VCU	conn4	C4	conn1	FTI	10	0.0001
6	VCU	conn5	C5	conn1	GNC	10	0.0001
7	VCU	conn6	C6	conn1	ERP	5	0.000025
8	VCU	conn7	C7	conn1	APU	10	0.0001
9	DLMU	conn2	C8	conn1	DLM1	2	0.000004
10	DLMU	conn3	C9	conn1	DLM2	2	0.000004
11	DLM1	conn2	C10	conn1	MXS-NC	5	0.000025
12	DLM2	conn2	C11	conn1	RS232	5	0.000025
13	BPDU	conn2	C12	conn1	BAT1	15	0.000225
14	BPDU	conn3	C13	conn1	BAT2	15	0.000225
15	BPDU	conn5	C14	conn1	BAT3	15	0.000225
16	BPDU	conn4	C15	conn1	BATENG1	15	0.000225
17	BPDU	conn6	C16	conn1	BATENG2	15	0.000225

Table 1: Example of an EXCEL connections-table. Each row in the table defines a connection and sets the values among others of the attributes 'Name' (column C), the pairs of 'Components' (columns A and G), the pairs of 'connectors' (columns B and F), 'diameter' (column I), 'mass/length' (column J).

With all these items defined in the graph, the 3D routing of all the connections can be automatically determined. With this graph based methodology the routing optimization is built on highly efficient routing algorithms. These algorithms are based on the well-known Dijkstra's algorithm [13] and the A* algorithm [14] and the subsequent variants and implementations thereof [15]. The algorithm used in NEXT is based on shortest path routes combined with weighting factors accounting for all sorts of preferences. For example preferences for minimization of number of bends, for preferred routing directions and for minimum clearances between connections and components can be included. Once the preferences are set, the routing of multiple connections is done sequentially. The NEXT tool provides user interfaces where the user can set the preferences and manage the order in which the connections shall be routed (figure 5), for example ordered by decreasing diameter.

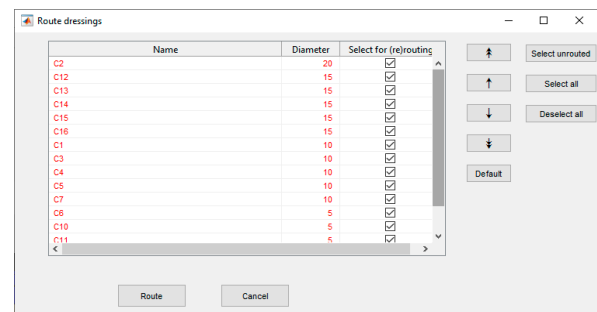
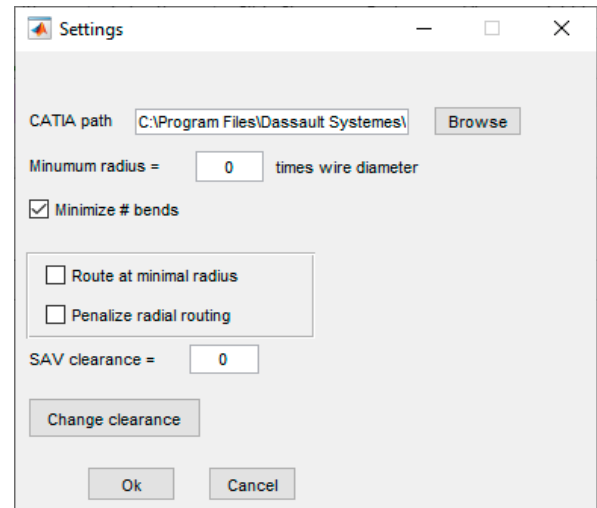

Figure 5: Illustration of the user interfaces of the NEXT tool where the user can set the routing preferences (upper picture) and manage the order in which the connections shall be routed (lower picture).

4. SIMPLIFIED DESIGN CASE: SCALED AIRCRAFT

The optimization methodology as implemented in the NEXT tool can be applied to electric system or sub-system installations on more electric, hybrid electric or fully electric aircraft. But to test and evaluate the methodology, the NEXT tool was applied in a simplified design case of the electric system installation on a scaled aircraft. In this case the 1:8.5 scaled version of an A320 aircraft is considered from the SCALAIR project [16]. This scaled aircraft has a wing span and fuselage length of about 4m and is developed for validation of scaled flight testing. Therefore this scaled aircraft is equipped with substantial electric measurement devices and electronic data links, as well as the electrically controlled primary flight controls. With its reduced scale, it is a challenge to define a feasible fit of all the equipment, most of which are placed in the confined space of the fuselage compartment.

As shown in Fig. 3, the SCALAIR fuselage CAD definition has been translated in a SAV file. During the last step, from STL file to SAV file the desired 3D cell resolution and coordinate system location and orientation are set, making use of the `make_sav` tool (figure 6).

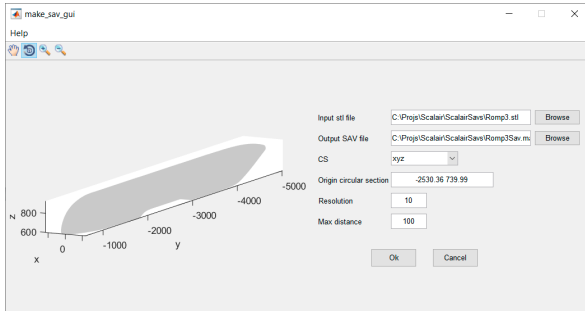

Figure 6: Illustration of the `make_sav` tool for the creation the SAV graph from the fuselage compartment STL file. Settings like the desired 3D cell resolution can be specified.

On board the SCALAIR scaled aircraft there are a large number of systems and sub-systems, as shown in the system overview schema (figure 7).

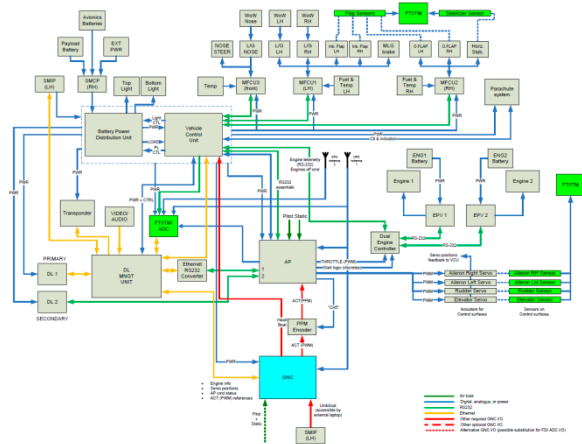

Figure 7: Overview schema of the main systems and sub-systems on board the SCALAIR scaled aircraft [16].

This study is not intended for delivering a complete and final design of the SCALAIR electric system. Instead it aims to test and evaluate the optimization methodologies implemented in the NEXT tool. Therefore, and for simplicity and clear illustration, only a subset of the main components of the electric system on board the SCALAIR scaled aircraft are considered. These components include among

others the Vehicle Control Unit (VCU), the Data Link Management Unit (DLMU) and the Battery Power Distribution Unit (BPDU). In total, 17 components are considered for which the simplified geometries can be extracted from the SCALAIR electric system CAD model (figure 8).

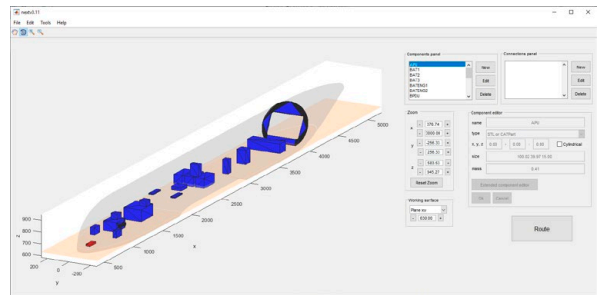
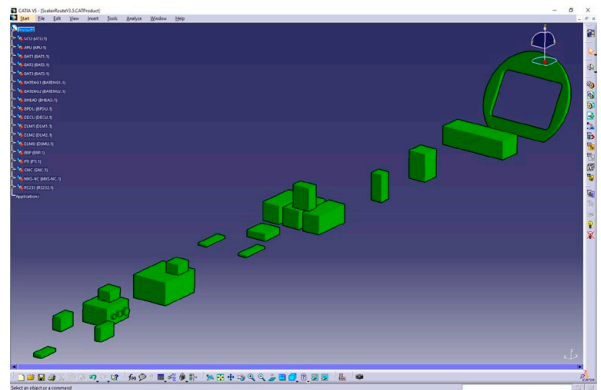
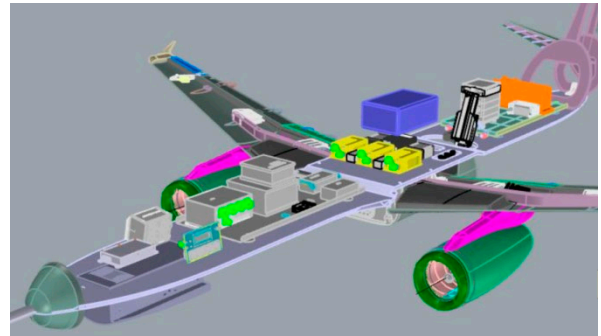

Figure 8: Illustration of the 17 components considered in this study. Their simplified geometries can be extracted from the SCALAIR electric system CAD model (defined in a RHINO [17] 3D CAD model; upper picture) and stored in CATIA CAD representation (middle picture). These component STL files can be directly imported into the NEXT tool (lower picture).

The simplified component geometries as defined in the CATIA 3D CAD representation can be easily translated to STL files. These component STL files can be directly imported into the NEXT tool (figure 8). For this purpose the components are further specified in a so-called *configuration*

file, which is an EXCEL file with two sheets, one for components and one for connections. The components sheet contains a table that defines on one row per component the attributes like name, shape, STL filename, mass, orientation, location, size, type and connectors. In this EXCEL configuration file the components can be easily manually edited, for example to add connectors or to change the component location in the SAV.

With all the components defined in the components sheet, now the connections can be specified in the connections sheet. The connections are essentially defined by pairs of connectors. For an example of the connections sheet see table 1. In this study only this example of 16 connections is considered. If more connections are desired these can be simply added to the connections sheet of the EXCEL configuration file. There is no limitation on the number of connections, but for simplicity and for clear illustration we stick to the 16 example connections. For each of the connections all attributes are defined, for example for C1 a diameter of 10mm and a mass of 0.1g/mm. After import of the EXCEL configuration file with the connections sheet, the connections are shown as straight lines between the connector locations in the NEXT tool (figure 9). It should be noted that the connections are colour coded according to their type attribute (for example based on ATA numbering system). The connections automatically inherit their type from the type attribute of their connector pairs. Here we have used the example type identifiers *ATAxx*, *ATAYy*, *ATAzz* and *Other* (see table 2).

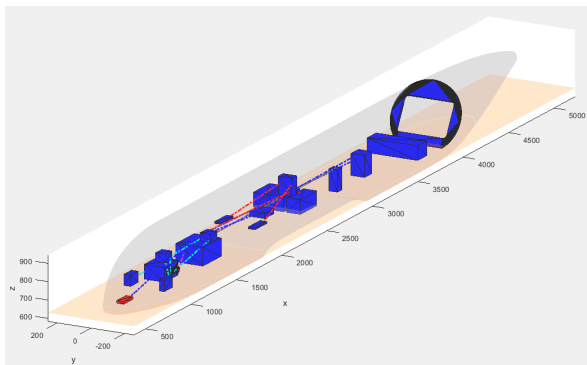

Figure 9: Indication of the 16 connections shown in the NEXT tool on the left as straight lines between the connector locations.

5. RESULTS

For the routing of the connections the default settings are used, as indicated in figure 5: the minimum bend radius of the connection's centreline is 0mm and the number of bends in connections is minimized. Penalty factors to avoid connections in radial directions and to prefer connections close to the fuselage centreline are not used. Minimum clearances between the connection and the SAV surface and the components are set to 0mm. Of course each of these settings can be changed to meet certain requirements for the system installation, for instance if the minimum clearance shall be 10mm this can be specified.

The automatic routing in the NEXT tool is subsequently executed for each of the 16 connections in the order given in figure 5. The total calculation time for these 16 connections in this SAV takes about 50s on a standard PC (Intel(R) Core(TM) i7-7820-HQ), which is in average about 3s calculation per connection. Part of the calculation however is dedicated to the pre-processing of the graph, which is memory intensive and increases strongly with increasing graph size. The present graph is based on a 10mm cell size (i.e. approximately 10mm 3D cube size). If a smaller grid size would be used to allow for higher resolution of the SAV and of the installation, the calculation time would increase. For example the calculation time would approximately double with a 20% decrease in cell size. Besides grid size also other factors like the number of components and the penalty factors and clearances can have influence on the calculation time.

After completion of the calculation, the resulting routes of the connections are shown directly in the NEXT tool as indicated in the figure 10. These connections can be automatically exported to CATIA Catparts, in order to include the routed connections in the conceptual design CAD model of the electric system installation (figure 10).

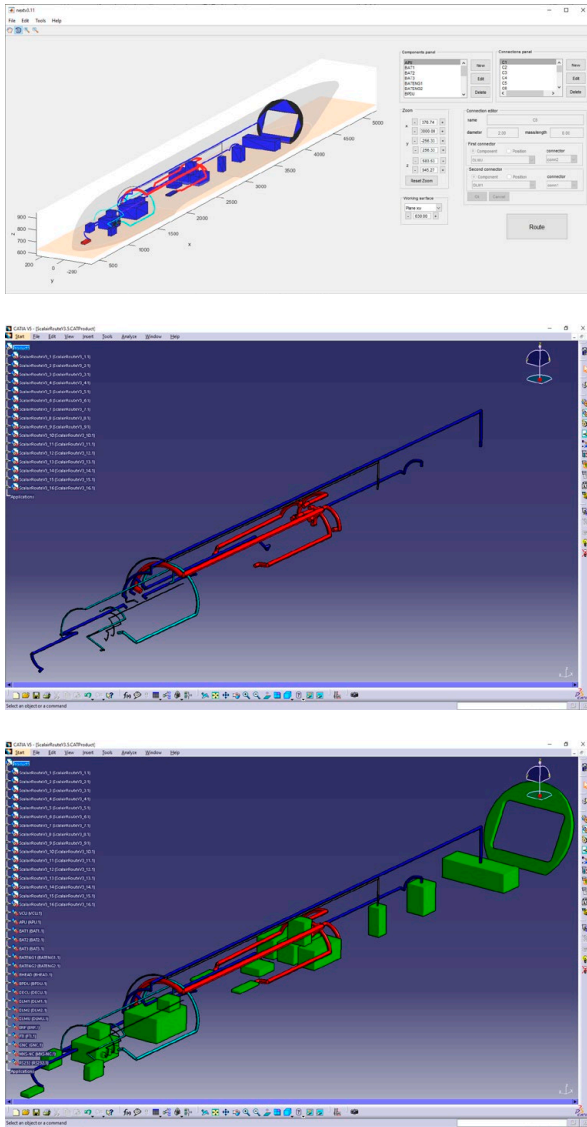

Figure 10: Illustration of the resulting routes of the connections shown directly in the NEXT tool (upper picture), and exported to CATIA as Catparts (middle picture) and included in the conceptual design CAD model of the electric system installation (lower picture).

The complete installation contains all the components in the right location and orientation and with all connections correctly routed in the SAV. With the NEXT tool an installation report (EXCEL file) can be generated listing all the main items in the installation and its properties: all the components with their mass, all the connections with their length, volume and mass, and the total mass and inertial properties of the complete installation (the latter is currently only based on the component masses). An example for the current installation is given in table 2.

	A	B	C	D	E	F
1	Name	Type	Diam	Length	Volume	Mass
2	C1	ATAzz	10	971	76262	0.0971
3	C2	ATAyy	20	1369	430084	0.5476
4	C3	ATAxx	10	999	78461	0.0999
5	C4	ATAxx	10	2609	204910	0.2609
6	C5	ATAxx	10	1955	153545	0.1955
7	C6	Other	5	1936	38013	0.0484
8	C7	ATAxx	10	926	72728	0.0926
9	C8	ATAzz	2	622	1954	0.002488
10	C9	ATAzz	2	247	776	0.000988
11	C10	ATAzz	5	902	17711	0.02255
12	C11	ATAzz	5	499	9798	0.012475
13	C12	ATAyy	15	285	50364	0.064125
14	C13	ATAyy	15	268	47360	0.0603
15	C14	ATAyy	15	407	71923	0.091575
16	C15	ATAyy	15	647	114334	0.145575
17	C16	ATAyy	15	635	112214	0.142875

	A	B	C	D
1	mass	28.75		
2				
3	center_of_mass_x	2934.323		
4	center_of_mass_y	9.900958		
5	center_of_mass_z	697.7737		
6				
7	Inertia tensor I _{i j}	232973.7	175951.6	186752.1
8		175951.6	18929087	5224.718
9		186752.1	5224.718	19021190

Table 2: Example of the report file's connections sheet (upper table) with all the connections' name, type, diameter, length, volume and mass values, and the inertia sheet (lower table) listing the total mass, the centre of mass location, and the moment of inertia tensor of the complete installation.

Of course additional properties of the installation can be easily included if desired. For example the minimum clearance between connections, or the

minimum distance between components occurring in the installation can be reported.

If the resulting connections are not satisfactory, rerouting with other settings can be easily done. For example, if the minimization of number of bends is not activated, a very different routing result is easily obtained within one minute (figure 11).

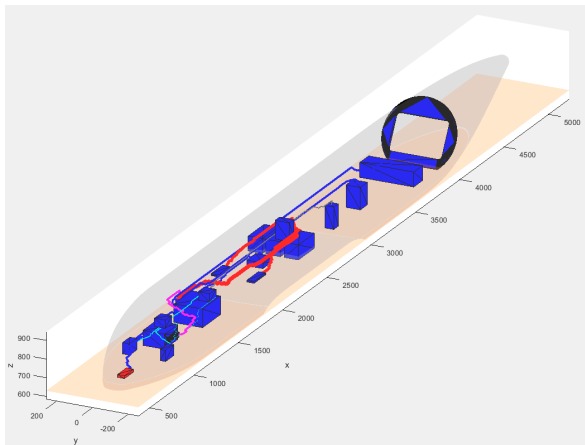
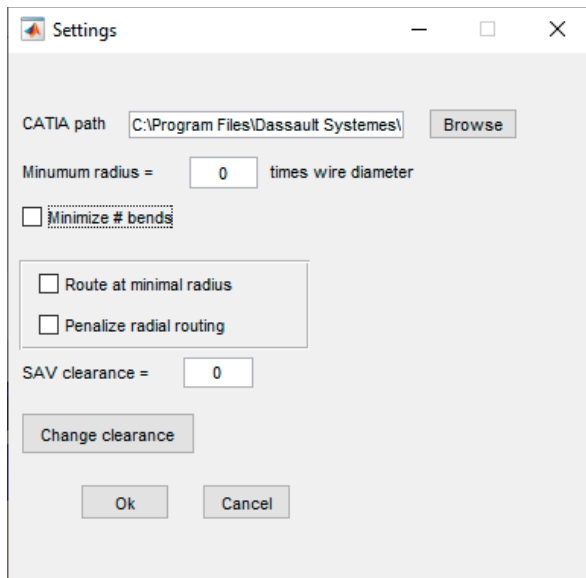

Figure 11: Illustration of the rerouting with other settings, for example with the minimization of number of bends not activated (upper picture). Then a very different routing result is found (lower picture).

6. CONCLUSION

This paper presents an efficient software tool (NEXT) for electric system installation optimization. The tool is built on graph based modelling and optimization methodologies and implemented in MATLAB. The focus for the

efficiency of this tool is on the easy integration with CAD systems, in particular CATIA. In this way the tool supports efficient design iterations in conceptual design phases where modifications in the electric system layout can be quickly optimized and exchanged with the aircraft level CAD models.

It is demonstrated for a design case of a basic electric system installation in a scaled aircraft that both efficiency and flexibility are ensured in this CAD integration process. The focus of this paper is not on the actual detailed design of the considered electric system, but more to present the efficiency and flexibility of the interoperability with CAD and how the conceptual design CAD data can be exploited through automated data exchange between the tool and CATIA.

The basic design case in this study considers only a subset of the main components of the electric system on board the SCALAIR [16] scaled aircraft. It is demonstrated how the geometric CAD data of the fuselage geometry and the electric components can be directly imported in the NEXT tool.

The calculation times for the optimized routings of the connections in this design case are promising for quick design iterations that enable the evaluation and optimization of many different variations of the component placement in the SAV.

Once the optimized routings of the connections have been determined, these can be directly exported back to the conceptual design CAD model of the electric system installation. In this CAD model more detailed assessments and further improvements can be made of the positioning of the components and the routed pathways of the connections. If needed, the improved CAD data can be imported again into the NEXT tool for another iteration of optimized placement and routing of the electric system items.

The methodologies used for the automated placement of components and routing are very flexible and well-suited for other industrial applications like harnesses routing and design for whole aircraft, wings or engines. Also other types of system installations can be modelled and

optimized in a similar way, including pneumatic and hydraulic systems or their combinations as commonly found in aircraft installations.

7. ACKNOWLEDGEMENTS

The authors want to thank the NLR colleagues involved in the SCALAIR project, E. Wegkamp, M. van Sijll and F. Bremmers, for their support.

8. REFERENCES

- [1] B. Sarlioglu, C.T. Morris (2015). More Electric Aircraft: Review, Challenges, and Opportunities for Commercial Transport Aircraft, IEEE Transactions on Transportation Electrification 1 (1) 54-64.
- [2] Q. Zhang, M. Sztzykiel, Pj. Norman, G. Burt (2018), Towards Dual and Three-Channel Electrical Architecture Design for More-Electric Engines, Aerospace Systems and Technology Conference, London, UK.
- [3] B.J. Brelje and J.R.R.A. Martins (2019). Electric, Hybrid, and Turboelectric Fixed-Wing Aircraft: A Review of Concepts, Models, and Design Approaches, Progress in Aerospace Sciences, 104:1-19.
- [4] https://www.boeing.com/commercial/aeromagazine/articles/qtr_4_07/article_02_1.html (last accessed 27 Dec 2019).
- [5] <https://www.ampaire.com/> (last accessed 27 Dec 2019).
- [6] <https://www.pipistrel-aircraft.com/aircraft/electric-flight/alpha-electro/> (last accessed 27 Dec 2019).
- [7] https://en.wikipedia.org/wiki/Airbus_A380 (last accessed 27 Dec 2019).
- [8] W.J. Vankan, R. Maas, V. Peyron (2017), Integrated equipment installation and optimisation for new engine architecture nacelles, in: proc. 7th European conference for aeronautics and space sciences (EUCASS), Milan, Italy, July 2017. NLR-TP-2017-297.
- [9] <https://www.3ds.com/products-services/catia> (last accessed 27 Dec 2019).
- [10] S. Rudolph, J. Beichter, M. Eheim, S. Hess, M. Motzer and R. Weil, On Multi-Disciplinary Architectural Synthesis and Analysis of Complex Systems with Graph-based Design Languages, in: Proc. 62. Deutscher Luft- und Raumfahrtkongress (DGLR 2013), Stuttgart, September 10-12 (2013).
- [11] Z. Zhu, G. La Rocca, M. J. L. van Tooren, A methodology to enable automatic 3D routing of aircraft Electrical Wiring Interconnection System, CEAS Aeronaut J (2017).
- [12] <https://mathworks.com/products/matlab.html> (last accessed 27 Dec 2019).
- [13] Dijkstra, E.W., "A note on two problems in connexion with graphs", Numerische Mathematik, 1: 269–271 (1959).
- [14] P.E. Hart, N.J. Nilsson, B. Raphael, A Formal Basis for the Heuristic Determination of Minimum Cost Paths, IEEE Transactions on Systems Science and Cybernetics SSC4. 4(2): 100–107 (1968).
- [15] N.P. Padhy: Artificial Intelligence and Intelligent Systems. Oxford University Press, Oxford (2005).
- [16] <https://cordis.europa.eu/project/id/717183> (last accessed 27 Dec 2019).
- [17] <https://www.rhino3d.com/> (last accessed 27 Dec 2019).



Dedicated to innovation in aerospace

Royal Netherlands Aerospace Centre

NLR is a leading international research centre for aerospace. Bolstered by its multidisciplinary expertise and unrivalled research facilities, NLR provides innovative and integral solutions for the complex challenges in the aerospace sector.

NLR's activities span the full spectrum of Research Development Test & Evaluation (RDT & E). Given NLR's specialist knowledge and facilities, companies turn to NLR for validation, verification, qualification, simulation and evaluation. NLR thereby bridges the gap between research and practical applications, while working for both government and industry at home and abroad.

NLR stands for practical and innovative solutions, technical expertise and a long-term design vision. This allows NLR's cutting edge technology to find its way into successful aerospace programs of OEMs, including Airbus, Embraer and Pilatus. NLR contributes to (military) programs, such as ESA's IXV re-entry vehicle, the F-35, the Apache helicopter, and European programs, including SESAR and Clean Sky 2. Founded in 1919, and employing some 600 people, NLR achieved a turnover of 76 million euros in 2017, of which 81% derived from contract research, and the remaining from government funds.

For more information visit: www.nlr.org

Postal address

PO Box 90502
1006 BM Amsterdam, The Netherlands
e) info@nlr.nl i) www.nlr.org

NLR Amsterdam

Anthony Fokkerweg 2
1059 CM Amsterdam, The Netherlands
p) +31 88 511 3113

NLR Marknesse

Voorsterweg 31
8316 PR Marknesse, The Netherlands
p) +31 88 511 4444