



Executive summary

Failure analysis of metallic materials: a short course

**Report no.**

NLR-TP-2010-550

Author(s)

S.A. Barter

S.P. Lynch

R.J.H. Wanhill

Report classification

UNCLASSIFIED

Date

February 2011

Knowledge area(s)

Vliegtuigmateriaal- en schadeonderzoek

Descriptor(s)

failure analysis

metals

aerospace

Problem area

Analysis of aircraft service failures is a demanding discipline, requiring a wide range of knowledge and expertise. There is no substitute for experience, and the key to successful failure analyses is teamwork that includes knowledge transfer. Recognising this, the NLR and DSTO have pooled their experience of some notable failures in aircraft metallic components and structures to provide a short (1-day) teaching course.

Description of work

The teaching course is concerned principally with aerospace metallic materials, and is in two parts. Part I covers general procedures, causes and types of failures, failure diagnosis, and a final summary of the required specialist knowledge and techniques. Part II consists of nine case histories drawn from DSTO and NLR experience. Both parts are presented in PowerPoint format.

Nationaal Lucht- en Ruimtevaartlaboratorium, National Aerospace Laboratory NLR

Anthony Fokkerweg 2, 1059 CM Amsterdam,
P.O. Box 90502, 1006 BM Amsterdam, The Netherlands

Telephone +31 20 511 31 13, Fax +31 20 511 32 10, Web site: www.nlr.nl



NLR-TP-2010-550

Failure analysis of metallic materials: a short course

S.A. Barter¹, S.P. Lynch¹ and R.J.H. Wanhill

¹ DSTO, Melbourne



This report is a joint research activity of the NLR (Amsterdam, the Netherlands) and DSTO (Melbourne, Australia).

The contents of this report may be cited on condition that full credit is given to NLR and the authors.

This publication has been refereed by the Advisory Committee AEROSPACE VEHICLES.

Customer	National Aerospace Laboratory NLR
Contract number	--
Owner	National Aerospace Laboratory NLR
Division NLR	Aerospace Vehicles
Distribution	Unlimited
Classification of title	Unclassified
	February 2011

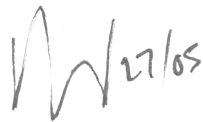
Approved by:

Author	Reviewer	Managing department
 27/05	 27/5/11	 31/5



Summary

Analysis of aircraft service failures is a demanding discipline, requiring a wide range of knowledge and expertise. There is no substitute for experience, and the key to successful failure analyses is teamwork that includes knowledge transfer. Recognising this, the NLR and DSTO have pooled their experience of some notable failures in aircraft metallic components and structures to provide a short (1-day) teaching course.

The teaching course is concerned principally with aerospace metallic materials, and is in two parts. Part I covers general procedures, causes and types of failures, failure diagnosis, and a final summary of the required specialist knowledge and techniques. Part II consists of nine case histories drawn from DSTO and NLR experience. Both parts are presented in PowerPoint format.

Contents

Part I	7
• Introduction	9
• General Procedures for Failure Analysis	12
• Causes and Types of Failure	30
• Failure Diagnosis: Fracture Modes	34
• Required Specialist Knowledge and Techniques	47
Part II: Case Histories	48
• Aermacchi MB-326H wing spar (1990)	49
• General Electric CF6-50 G40 turbine blades (1977-79)	55
• De Havilland Canada DHC-4 Caribou / Pratt & Whitney R2000 components (1970-84)	59
• Boeing 747-258F engine + pylon losses (1992)	64
• Fokker F50 / Pratt & Whitney 125B bearing (2002)	72
• Aérospatiale Alouette III helicopter tail lug (1990)	78
• Boeing F/A-18 trailing edge flaps (1993)	81
• General Dynamics F-16 / Pratt & Whitney F100-PW-220 RCVV lever arm pin (1992)	92
• Westland Lynx SH14D helicopter rotor hub (1998)	97

Part I



Failure Analysis of Metallic Materials: A Short Course

Defence Science and Technology Organisation DSTO, Melbourne

National Aerospace Laboratory NLR, Emmeloord

Nationaal Lucht- en Ruimtevaartlaboratorium – National Aerospace Laboratory NLR



- **Main Editors:** Russell Wanhill, Simon Barter
- **Principal Contributors:** Simon Barter, Stan Lynch, Russell Wanhill

Course Overview



- **Introduction**
- **General Procedures for Failure Analysis**
- **Causes and Types of Failures**
- **Failure Diagnosis: Fracture Modes**
- **Required Specialist Knowledge and Techniques**
- **Case Histories**



Introduction

DSTO Fishermans Bend, Melbourne

- **Aircraft Forensic Engineering,
Air Vehicles Division (AVD)**



NLR Locations

NLR-Amsterdam



NLR-Flevoland

Failure Analysis

8-11-2010 6

Introduction: Failure Analysis is part of *Forensic Engineering*



● **Forensic Engineering includes:**

- Failure analysis of metallic, non-metallic and composite materials
- Corrosion investigations of materials and components
- Identification of materials and processing problems
- Identification of systems problems and hazards
- Non-destructive testing (including evaluation and development)
- Wear debris analysis
- Fuel and oil analyses

8-11-2010 7

Why is Failure Analysis Required?

Investigation of failed and / or damaged components, especially fracture surfaces, can be crucial to explaining incidents, accidents and disasters



General Procedures for Failure Analysis

Obtaining Background Information - I *(easier said than done!)*

- Description of failed components and their functions
- 'Abnormal' events prior to failure?
- Duration of service; inspection / maintenance schedules
- Details of maintenance, including NDI
- Any repairs, refurbishments, etc.?
- Events after failure, e.g. fires
- Details of previous failures *(and actions taken, if any)*
N.B: OEMs can be unreliable – "isolated case" syndrome

Obtaining Background Information - II

- Visit site (when merited)
- Talk to operators (not just 'management') but
- *DO NOT make premature pronouncements*
- Take photographs of failed parts and adjacent areas / ancillary equipment **BEFORE** and after dismantling



PLAN investigation

- If litigation could be involved, obtain approval before action is taken that could alter evidence
- Preserve evidence against further damage and deterioration
- Measurements (GPS) of wreckage distribution may be necessary

On-Site Preservation of Evidence

- *Lightly* clean and dry (fracture) surfaces if covered by corrodents, *e.g. fire retardants, soil*, but **DO NOT** remove adherent materials
- For small components use desiccants to keep fracture surfaces dry
- Possibly temporarily cover with grease or commercial sprays, if they are *easily* removed
- Package pieces *separately* for transportation: avoids damage

Handle Fractures With Care (This is a classic problem!)

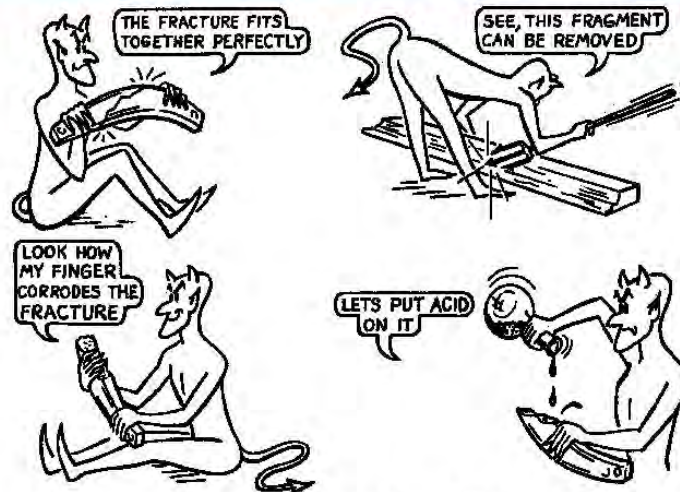

HANDLE FRACTURES WITH CARE

From the Electron Fractography Handbook, Tech Rep. ML-TDR-64-416, AFML, 1965

8-11-2010 13

Obtaining Background Information - III



- Specified Material (Composition)
 - Fabrication, *e.g. casting, forging; hot/cold working*
 - Joining processes, *e.g. welding, brazing*
 - Heat-treatment, *e.g. ageing/ tempering times and temperatures*
 - Mechanical properties, *e.g. yield strength, V_H , ductility, K_{Ic}*
 - Finishing processes, *e.g. machining, shot-peening, carburising, electroplating, etc.*

14

For finishing processes “minor” details may be important

Example: electroplating

- Thickness and uniformity of plating
- Cracks in plating, *e.g. hard chrome*
- Porosity, *e.g. “bright” or “porous” cadmium*
- Time between plating and baking
- Baking time and temperature (*a classic problem*)

15

For some components “minor” details may be important

Example: bolts

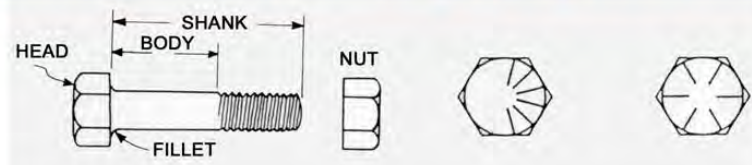

- Threads rolled or machined (cut)?
- Specified torque (and torques to loosen any remaining bolts)
- Lubrication/coatings
- Sequence of tightening and tool used for tightening
- Joint design and loading mode
- Position of failure initiation and sequence of failure in joint

Ref: J.H. Bickford, *An Introduction to the Design and Behavior of Bolted Joints*, 2nd Ed., 1990.

16

Obtaining Background Information - IV

In-service and pre-service stresses:

- ***Tensile or torsional; residual; stress concentrations***
nominally sustained

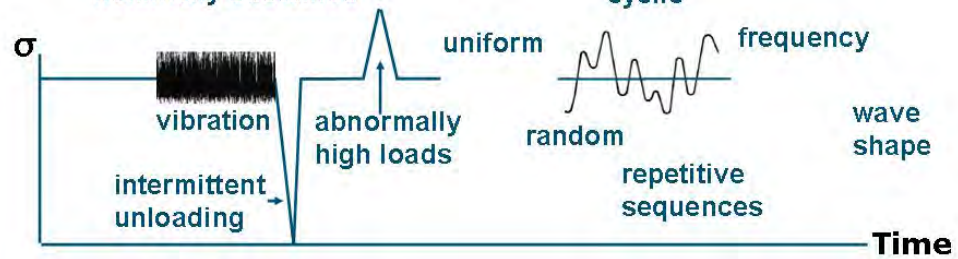

- ***Be alert for non-obvious sources of cyclic stresses***

17

Obtaining Background Information - V

Expected in-service and pre-service environments and temperatures

- Air of varying humidities
- Aqueous solutions: potential, pH, dissimilar metal contact, cathodic protection
- Elevated temperatures: engines, chemical plant

8-11-2010 18

Analysis of Materials and Environments

- For materials and environments even *ppm* impurity levels can sometimes be important, e.g.:
 - O, N, H in Ti alloys
 - C in ancient phosphoric iron
 - Cl⁻ for stress corrosion cracking of stainless steels
- Local environments, e.g. in crevices, may be critical
- Measure potentials / check effectiveness of cathodic protection
- Check:
 - dimensions
 - bulk / near-surface microstructure
 - hardness

9-11-2010 19

Field Metallography: *sometimes* useful



20

Exposing Fracture Surfaces of Partially Cracked Components - I

- Photograph and/or mark crack tip first
- If fractured region needs to be cut out: *avoid damaging (heating!) surrounding material*
- Use saw, without lubrication, to minimise remaining cross-section (*remembering crack fronts may be curved, etc.*)
- Break apart in tension/bending to avoid fracture surface contacts

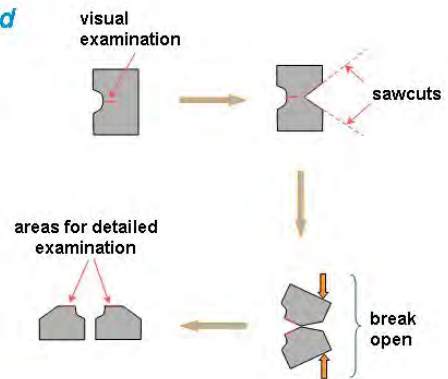

N.B: If the primary fracture surface is badly damaged, try opening up any secondary cracks

Exposing Fracture Surfaces of Partially Cracked Components - II

- For small cracks, material can be removed by *in situ* Electric Discharge Machining (EDM) and then fractured

- Example of cracks requiring careful opening

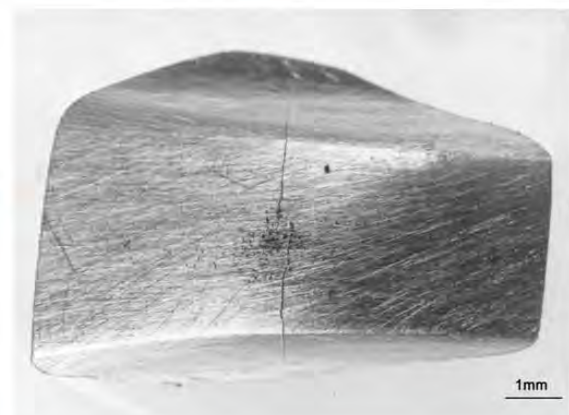

Exposing Fracture Surfaces of Partially Cracked Components - III



- An *ad hoc* rig may sometimes be needed: manganese alloy propeller



23

Cleaning of Fracture Surfaces



- Dry air blast or soft organic-fibre brush cleaning
- Repeated stripping of replicas plus ultrasonic cleaning in reagent-grade acetone or other organic solvents
- Organic-solvent cleaning: check compatibilities, *e.g. with carbon fibre composite components*
- Cathodic cleaning, using inert Pt or C anode: deposits are dislodged by hydrogen gas evolution
- Water-based detergent cleaning
- Inhibited acid cleaning (concentrated HNO_3 for aluminium alloys)

24

Fractographic Techniques/Equipment

- Optical Microscopy (*including Deep Focus*) 1 – 1500X
- Scanning Electron Microscopy (SEM):
SE and back-scattered electron (BSE) modes; FE-SEM to $\geq 40,000X$ 10 – 20,000X
- Transmission Electron Microscopy (TEM)
(hardly used nowadays) 1,000 – 50,000X
- Energy Dispersive (X-ray) analysis (EDX)
(or Microprobe analysis)

25

Optical Microscopy

- Slight tilts / undulations and colours are readily detected
- Limited depth of field and resolution ($\sim 1 \mu\text{m}$)*
- Long-working distance objective lens (50X) useful
- Contrast can be enhanced by oblique illumination, interference contrast, etc.

*Deep Focus Optical Microscope (DFOM): digital construction of an in-focus image from a series of images at different heights, *see next slide*

26

DSTO Deep Focus Optical Microscope

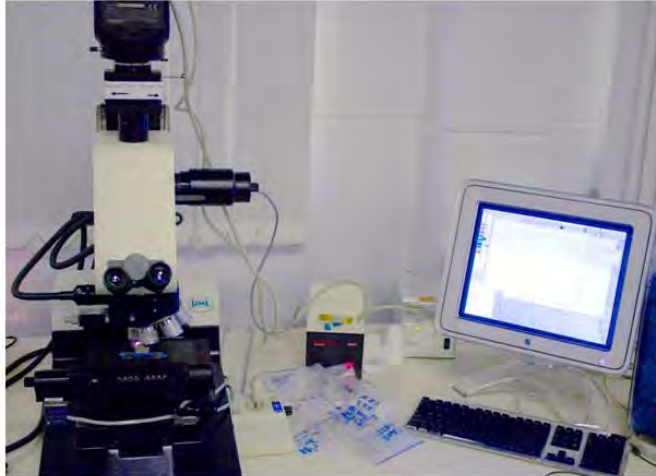

- A very rigid measuring microscope with:
 - long working distance objectives up to 150X
 - a chilled (low noise) digital camera
 - stepping-motor-driven stage (X, Y, Z directions in steps <math>< 1\mu\text{m}</math>) and with computer control
 - a modified version of *NIH Image* to drive the stage and the camera

8-11-2010 27

Deep Focus Optical Fractograph: same area as in slide 31

- Fatigue crack growth threshold in 7075-T7351 aluminium alloy plate

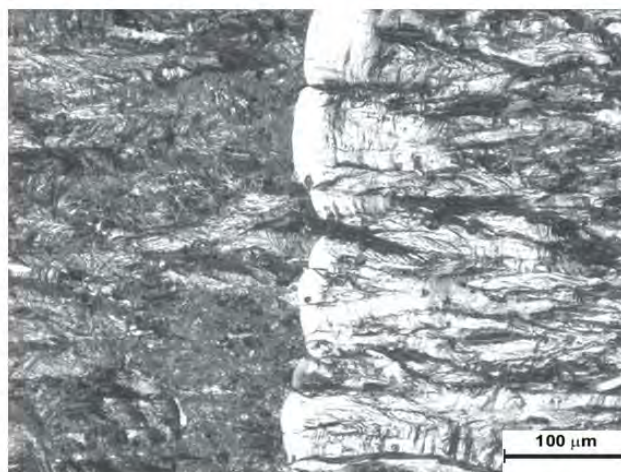

8-11-2010 28

Field Emission Scanning Electron Microscope (FE-SEM)



- **Advanced SEM with:**
 - better resolution
 - low keV operation + negligible electrical charging of samples
 - less need to place conducting coatings on insulating materials
 - range of integrated analysis equipment (EDX, WDX, EBSD)

Scanning Electron Microscopy (SEM)

- **Secondary electron (SE) mode – reveals surface topography**

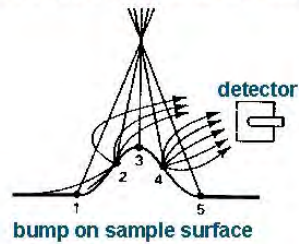

Intensity of Secondary Electrons (weakly bound electrons from 1-10nm depth) is greater from position 4 than position 2

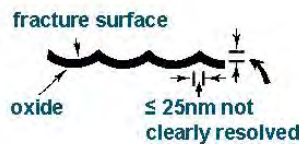
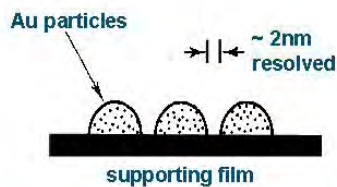

Scanning Electron Microscope (FE-SEM) Fractograph: same area as in slide 28



- Fatigue crack growth threshold in 7075-T7351 aluminium alloy plate

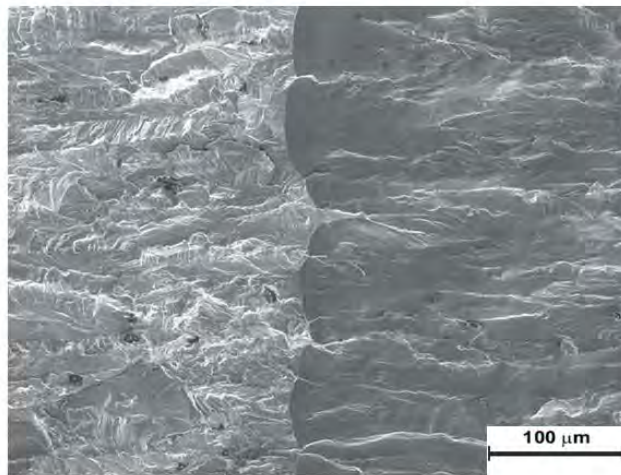

Stereographic Fractography - I: Stereo pairs are essential for proper appreciation of fracture surface topography

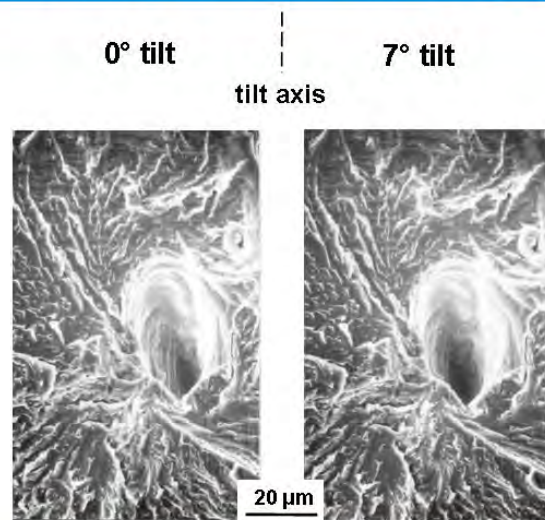

- Internal hydrogen embrittlement of a nickel single crystal

Stereographic Fractography - II: Anaglyphs (superimposed stereo pairs)

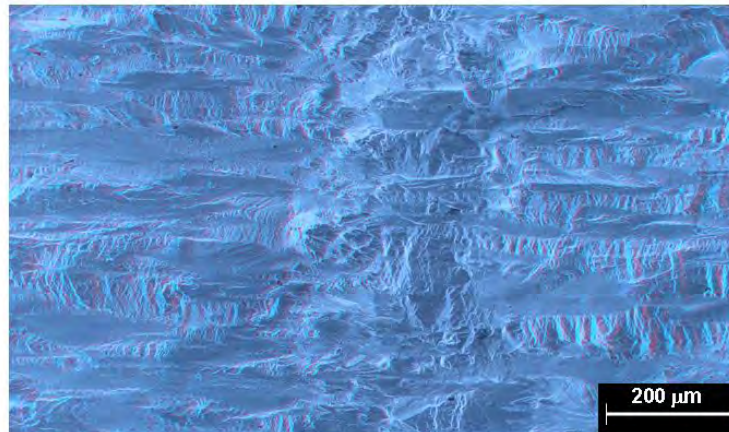

Quantitative Fractography (QF) - I: Optical fractographs for (a) 7075-T6 and (b) 2014-T6 aluminium alloys

(a) Wing spar service failure



Fatigue crack from (very) badly drilled fastener hole

Note fracture surface progression markings. These are important for **Quantitative Fractography (QF)** measurements of crack growth (tests and service failures)

(b) Flight simulation test

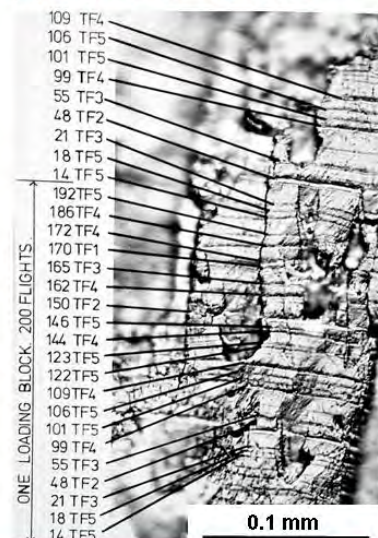

Quantitative Fractography (QF) - II: Airbus MegaLiner Barrel fatigue test, FE-SEM fractographs

- Fatigue striations, one per cabin pressurization cycle, in the passenger door beam area: GLARE laminate aluminium alloy 2024-T3 layer

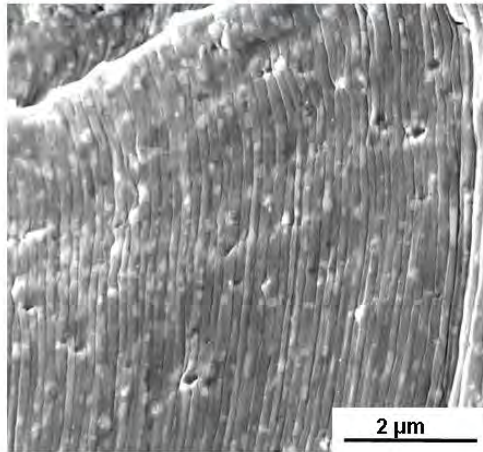

- Severe flight marker bands in window frame: aluminium alloy 7175-T73

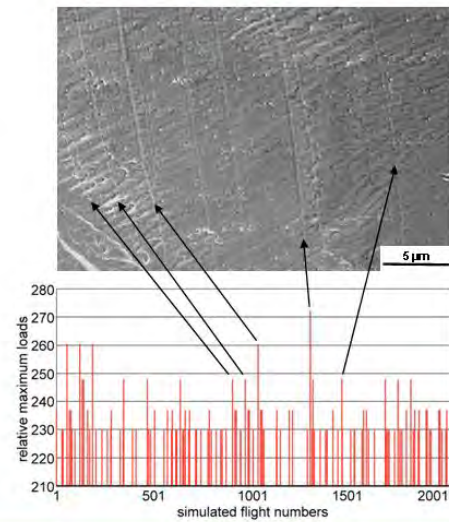

Ancillary Techniques: Metallographic sections through fracture surfaces

- Plane section: intergranular cracking owing to hydrogen embrittlement of a martensitic high-strength steel

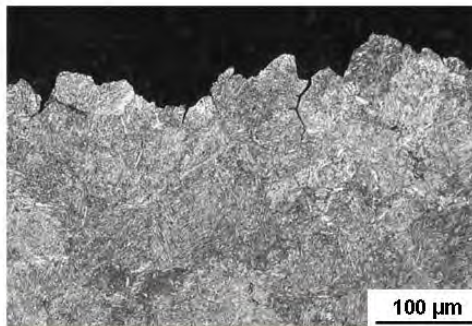

optical metallograph

- Precision section: fatigue crack growth in a Ti-6Al-4V titanium alloy (primary α + transformed β)

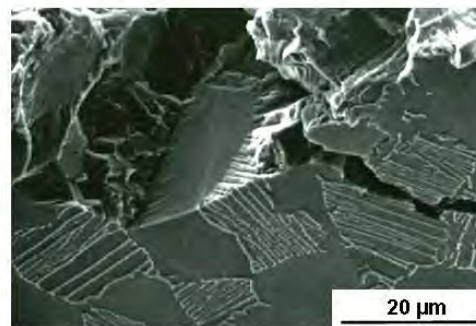

SEM metallograph/fractograph

Summary of Fracture Surface Examinations – I: Techniques

- Visual
- Stereo-binocular
- Macrofractography: uncleaned
- Microfractography : uncleaned
 - chemical analyses of contaminations, *e.g. EDX*
- Macrofractography: cleaned
- Microfractography : cleaned
 - material analyses, *e.g. EDX, WDX*
- Metallographic sections
 - through fracture surfaces
 - other locations

At each stage:

Make permanent records of evidence and observations

Preserve original evidence as much as possible

If litigation could be involved:

Obtain approval before actions are taken that could alter evidence

Ensure permanent records include times and dates of examinations and witness signatures

9-11-2010 37

Summary of Fracture Surface Examinations – II: Purposes

- Failure diagnosis
 - fracture modes
 - incorrect material selection and/or material deficiency
 - crack initiating discontinuities and defects
 - poor design, *e.g. high stress concentrations (known since 1844!)*
 - unanticipated adverse stresses and environmental conditions
- Quantitative Fractography (QF) of fatigue crack growth
 - crack growth curves
 - crack growth rates
 - crack initiation and growth lives

38

Writing a Failure Analysis Report - I: Before you start

- **Learn to write properly! Some suggestions:**
 - “How to Write and Publish Engineering Papers and Reports”, by H.B. Michaelson
 - “The Complete Plain Words”, by Sir Ernest Gowers
 - “Usage and Abusage”, by Eric Partridge
 - “The Penguin Guide to Punctuation”, by R.L. Trask

- **Purchase:**
 - A good dictionary
 - An up-to-date revised and expanded edition of Roget’s Thesaurus

both with English rather than American spellings



Writing a Failure Analysis Report - II: Outline

- | | |
|-------------------------------------------------------------------------------------------------------------------------------------------------------------------------------------------------------------------------------------------------------------------------------------------------------------------------------------|------------------------------------------------------------------------------------------------------------------------------------------------------------------------------------------------------------------------------------------------------------------------------------------------------------------------------|
| <ul style="list-style-type: none"> ● Heading/Title
— Author(s) and Signatures! ● Summary ● Table of Contents ● Nomenclature <i>(sometimes needed)</i> ● Introduction ● Investigative Procedures ● Results | <ul style="list-style-type: none"> ● Discussion(s) ● Conclusions ● RECOMMENDATIONS! ● Acknowledgements <i>(sometimes)</i> ● References ● Tables, Figures <i>(in report or at the end)</i> ● Appendices |
|-------------------------------------------------------------------------------------------------------------------------------------------------------------------------------------------------------------------------------------------------------------------------------------------------------------------------------------|------------------------------------------------------------------------------------------------------------------------------------------------------------------------------------------------------------------------------------------------------------------------------------------------------------------------------|

Writing a Failure Analysis Report - III: Content guidelines

- **An excellent starting point is:**
 - “Preparing and Writing a Failure Analysis Report”, by Steve McDanelis, *Practical Failure Analysis*, Vol. 2(5), October 2002, pp. 20, 47-50
- **Font suggestions**
 - Text and tables
 - serif: Times New Roman, Book Antiqua
 - sans-serif: Arial, Calibri, Verdana
 - but confusion is possible, e.g. | and | instead of | and |*
 - Figures
 - sans-serif: Arial *or* Arial

Writing a Failure Analysis Report - IV: Tables

- A good table can provide readily surveyed information *but is not easy to make*

Table 3 Guidelines for prevention of corrosion and SCC in aerospace vehicles

Types of structures	General guidelines	Specific guidelines		
		Materials	Coatings	
Primary structures and mechanical systems	<ul style="list-style-type: none"> • Restrict strength levels • Protective coatings where necessary for corrosion and SCC protection of Al alloys and low alloy steels 	Al alloys for primary structures and landing gear: - AA2000 series in T8XX tempers - AA7000 series in T7XX tempers	Anodising or chemical conversion + paint systems	
		Low alloy steels, UTS < 1400 MPa (higher strengths for landing gear)	Cd, Cr or Ni plating + paint systems	
		Stainless steels: PH grades ≥ H1000 temper	–	
		Ti alloys	–	
Fluid systems	<ul style="list-style-type: none"> • Use materials compatible with fluids without protective coatings • Control fluid chemistry 	Potentially aggressive environments		
			Materials	
		H ₂ O (aqueous solutions)	Pressure vessels	Plumbing lines and components
		NH ₃ , N ₂ H ₄ , N ₂ O ₄	Al alloys, possibly coated; Ti alloys	Stainless steels
		Freons	Ti alloys	AISI 300 series stainless steels
Hydraulic fluids	Al alloys	21-6-9 stainless steel		
		Cr-plated low alloy steels	Al and Ti alloys; stainless steels	

Writing a Failure Analysis Report - V: Figures

- Figures should be kept simple, *i.e. no fancy art work*
- Graphs should not be EXCEL defaults!
- Grids should be appropriate to what can be read from the figures
- Line thickness should provide good visibility but not be heavier than necessary
- Sans-serif fonts work well for legends and coordinate labels
- Font sizes should be appropriate: not too large or small
- Legends should be within the graph area
- Colours should be used with discretion or if necessary

Writing a Failure Analysis Report - VI: Figure examples

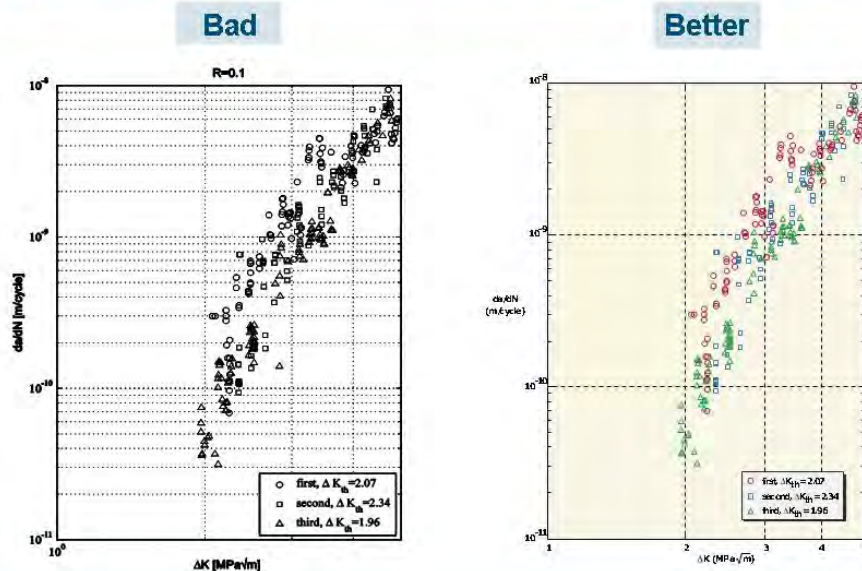

Causes and Types of Failures

45

Three main groups of failures*

- Failures attributable to faulty design considerations or incorrect materials selection
- Failures due to faulty processing
- Failures due to deterioration during service

* “Essential Metallurgy for Engineers”, by W.O. Alexander, G.J. Davies, S. Heslop, K.A. Reynolds and V.N. Whittaker

46



Causes of Failure in Some Engineering Investigations

Causes	Percentage of failures
<i>Improper materials selection</i>	38
Fabrication defects	15
Faulty heat treatments	15
Mechanical design faults	11
Unforeseen operating conditions	8
Inadequate environmental control	6
Improper or lack of inspection and quality control	5
Material mix-up	2



Causes of Failure from 230 Aircraft Failure Analysis Reports

Causes	Percentage of failures
<i>Improper maintenance</i>	44
Fabrication defects	17
Design deficiencies	16
Abnormal service damage	10
Defective material	7
Undetermined	6

Failure Type Frequencies

Failure types	Percentage of failures	
	Aircraft structures	Engineering industry
<i>Fatigue</i>	55	25
Corrosion	16	29
Brittle fracture	-	16
Overload	14	11
High temperature corrosion	2	7
Stress corrosion/corrosion fatigue/hydrogen embrittlement	7	6
Creep	-	3
Wear/abrasion/erosion	6	3

Threats to Aircraft Structural Safety*

Threats	Failure types
High local stresses	Fatigue
Fabrication/material defects	Fatigue
Maintenance damage/deficiencies	Fatigue
Widespread Fatigue Damage (<i>ageing aircraft</i>)	Fatigue
Environmental damage	Corrosion, stress corrosion
High operational loads	Overload
Impact (<i>various sources</i>)	Abrupt cracking, fatigue
Explosive/ballistic penetrations	Abrupt cracking

* USAF Report ASC-TR-2010-5002, C.F. Tiffany, J.P. Gallagher and C.A. Babish,IV

Summary: Main Causes and Types of Failures

- **Engineering industry**
 - cause: improper materials selection
 - types : fatigue and corrosion

- **Aircraft**
 - cause: improper maintenance
 - type : fatigue

Failure Diagnosis: Fracture Modes

52

Two main classifications and some mechanisms – I: Intergranular Fracture

- **Brittle**
 - hydrogen embrittlement: especially high-strength steels
 - segregation-induced embrittlement: temper embrittlement
 - precipitation of an embrittling phase
 - stress corrosion cracking (SCC)

- **Ductile**
 - overload by intergranular microvoid coalescence
 - high temperature creep and creep rupture

N.B: Intergranular fracture is generally a sign of reduced mechanical properties, although it is a normal failure mode in creep

8-11-2010 53

Two main classifications and some mechanisms – II: Transgranular Fracture



- **Brittle**
 - cleavage on crystallographic planes
 - stress corrosion cracking with cleavage-like appearance
- **Ductile**
 - tensile, shear and tearing overload by microvoid coalescence
- **Microductile**
 - fatigue, sometimes with progression markings and well-defined striations
 - corrosion fatigue
 - wear: galling, erosion, abrasion, fretting

N.B: Excepting wear, fracture appearances are very varied

9-11-2010 54

Brittle Intergranular Fracture – I: Hydrogen embrittlement of a martensitic high-strength steel



- **Wing tank aft pivot bolt: cadmium plated + copper grease; *post-failure* rusting especially on overload area**
- **SEM fractograph near thread root: the arrow points to local rusting**

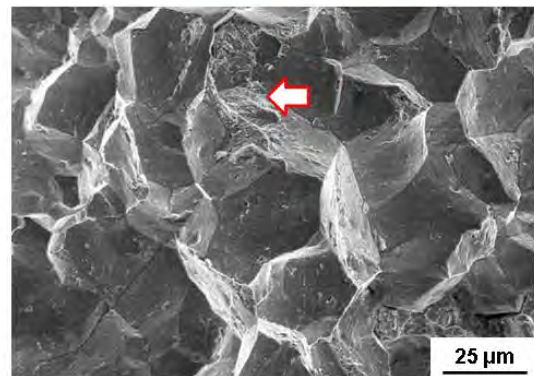

55

Brittle Intergranular Fracture – II: Segregation-induced embrittlement of a decarburised phosphoric iron Roman pile-shoe (c. 350 AD)



- Fracture from falling to hard floor during storage: 3 broken bars, one break due to the recent (c. 2000 AD) impact

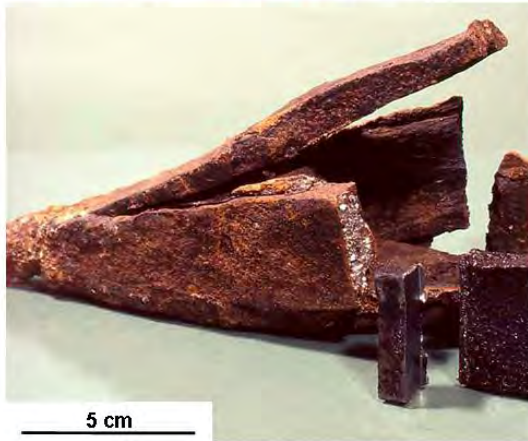

- SEM fractograph of clean-looking large ferrite grains up to 2 mm in diameter

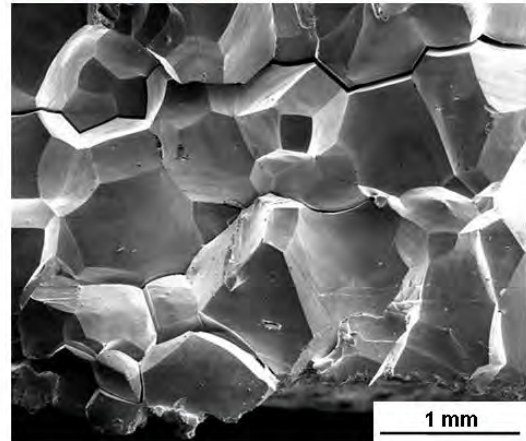

56

Brittle Intergranular Fracture – III: Schematics of SCC in aluminium alloys



- Equiaxed grains (recrystallized microstructure)

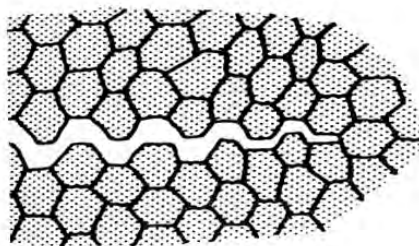

- Elongated grains (unrecrystallized "pancake" microstructure): crack path normal to *short transverse direction* of product or component

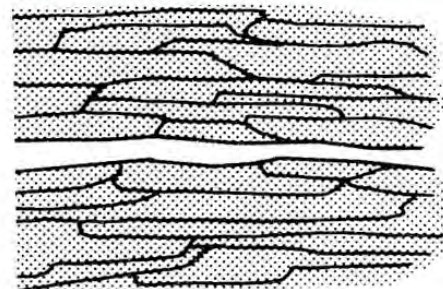

57

Brittle Intergranular Fracture – IV: Examples of SCC in aluminium alloys



- Flap track hinge: forged 7079-T651; the L.H. arrow points to the crack initiation site

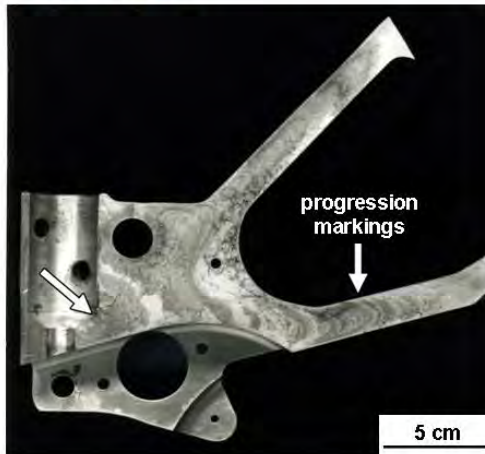

- SEM fractograph of aircraft cockpit window frame: 2024-T3 extrusion with elongated grains

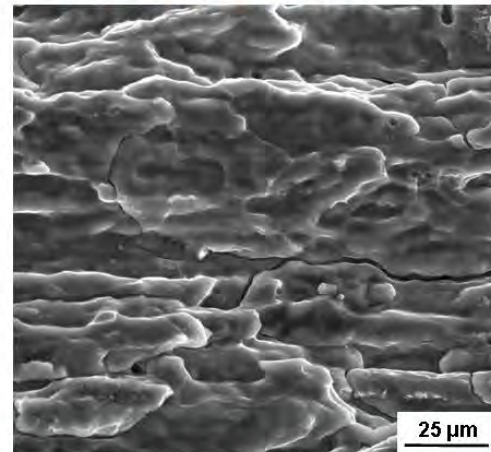

58

Ductile Intergranular Fracture - I: Experimental Al-Zn-Mg aluminium alloy



- Transmission Electron Microscope (TEM) fractograph of a carbon film direct replica, showing microvoid coalescence along grain boundaries

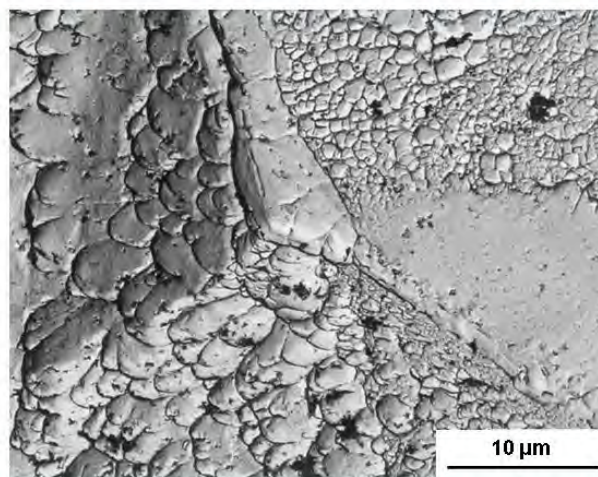

59

Ductile Intergranular Fracture - II: Schematics of the beginnings of creep rupture



- Low temperature – high stress creep: grain boundary sliding

- High temperature – low stress creep: grain boundary voids

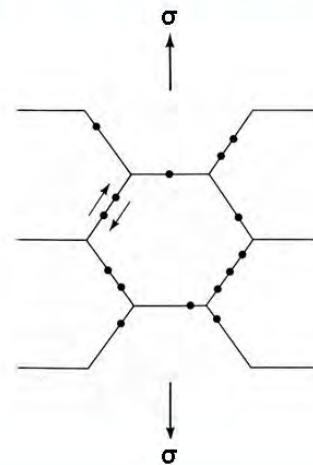
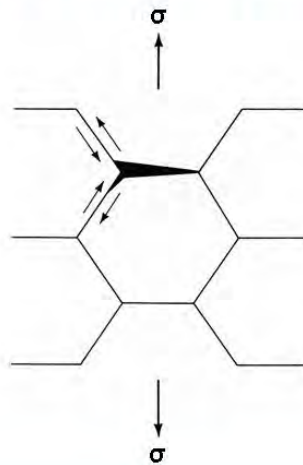

60

Ductile Intergranular Fracture - III: SEM fractographic examples of creep rupture in nickel-base superalloys



- Intergranular fracture owing to grain boundary sliding and coalescence of grain boundary microvoids; and some post-fracture oxidation

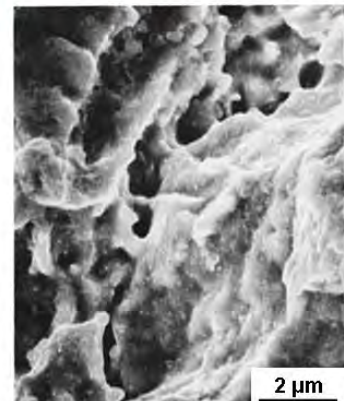
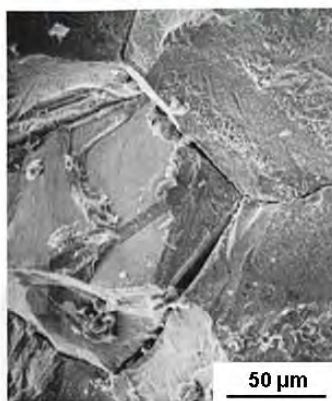

61

Brittle Transgranular Fracture – I: Schematics of cleavage

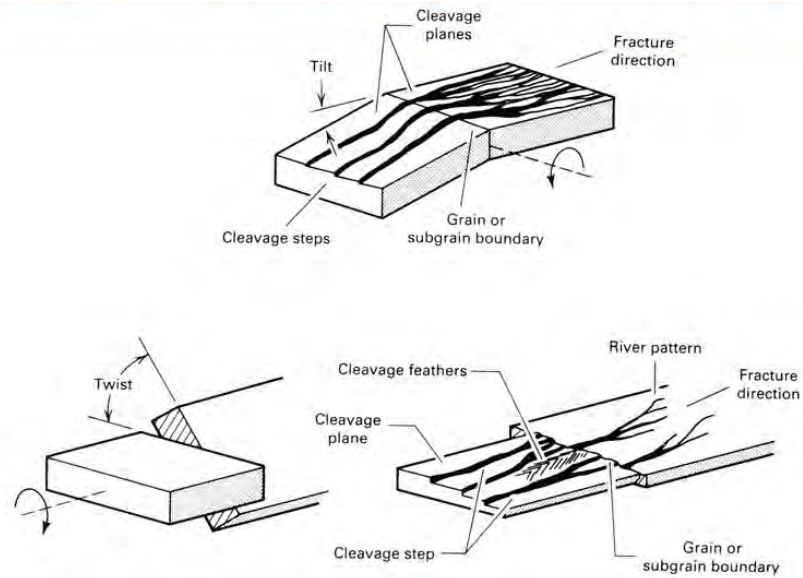

62

Brittle Transgranular Fracture – II: SEM examples of cleavage in a microalloyed HSLA steel



- **Fractograph of cleavage through many grains**

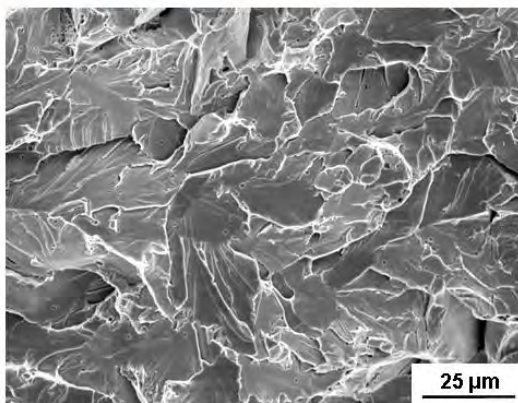

- **Metallograph of crack initiation at a grain boundary carbide**

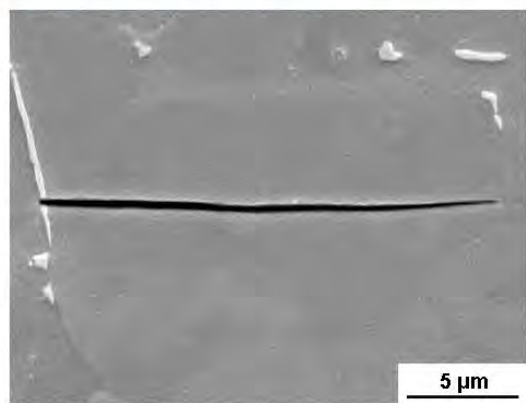

63

Brittle Transgranular Fracture – III: SEM fractograph examples of SCC



- “Cleavage-like” SCC in an austenitic stainless steel, Nitronic 60
- Cleavage and “fluting” (*ductile void formation mainly by prismatic slip*) in a titanium alloy, Ti-8Al-1Mo-1V

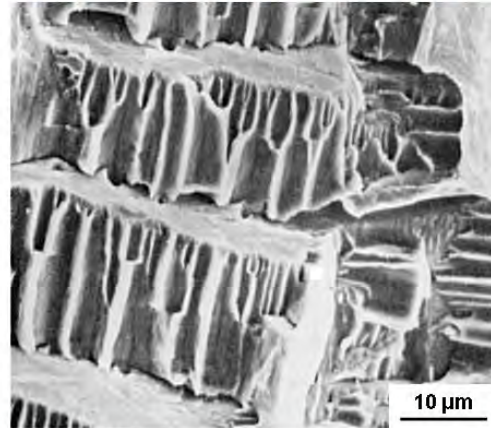
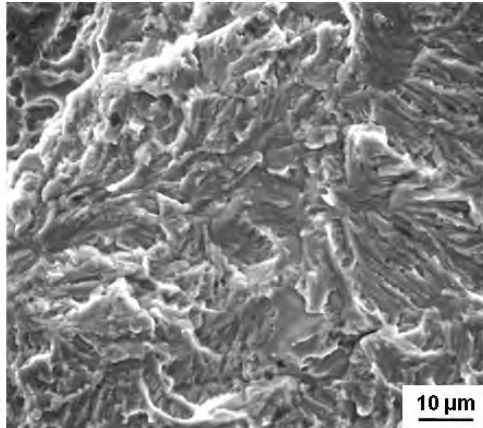

Ductile Transgranular Fracture – I: Schematic of tensile overload



- Microvoid coalescence with equiaxed dimples (*diagnostic*)

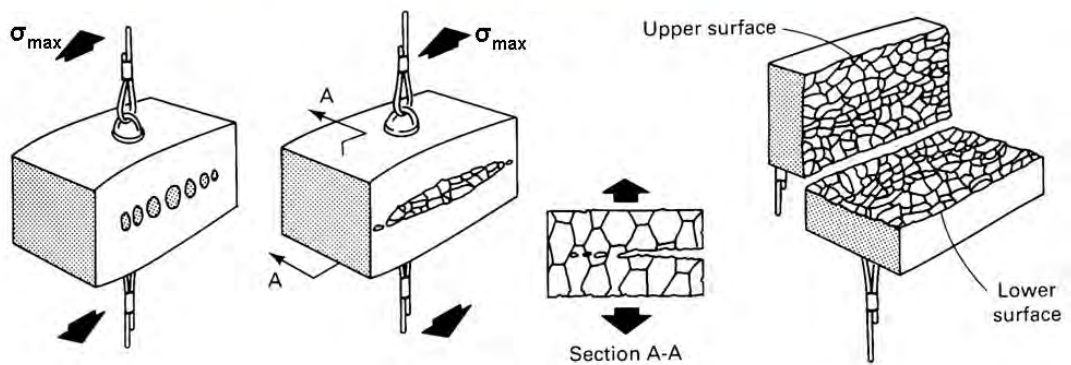

Ductile Transgranular Fracture – II: Schematic of bending overload



- Microvoid coalescence with elongated dimples pointing in the same direction (*diagnostic*) on the fracture surfaces

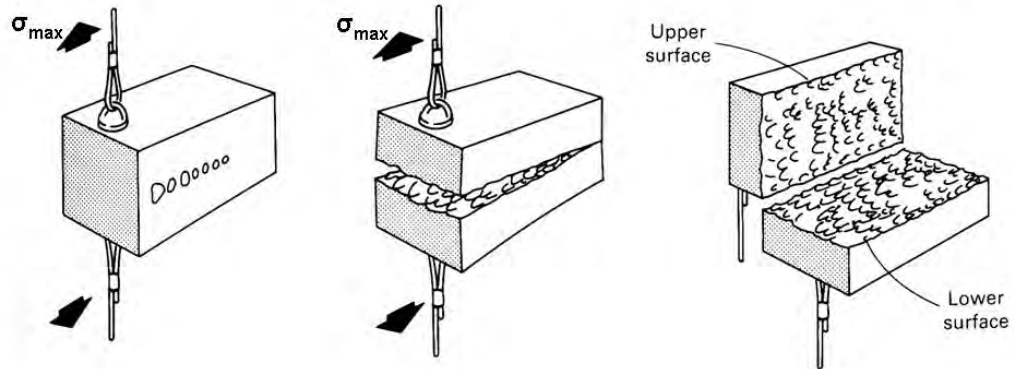

66

Ductile Transgranular Fracture – III: Schematic of plane shear overload



- Microvoid coalescence with elongated dimples: note different dimple directions (*diagnostic*) on the fracture surfaces

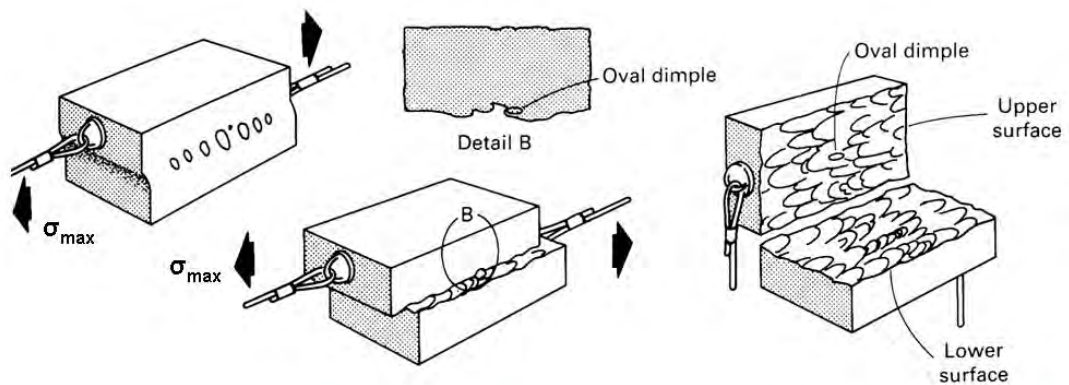

67

Ductile Transgranular Fracture – IV: SEM fractograph examples of microvoid coalescence: equiaxed and (slightly) elongated dimples

- Spring steel

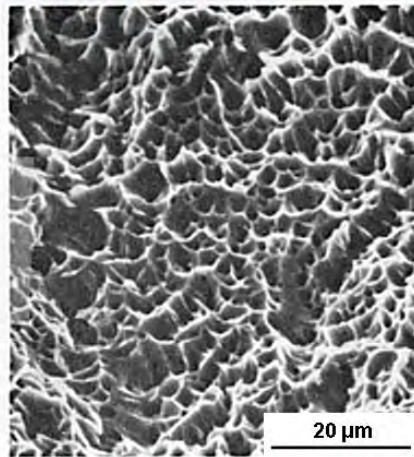

- Maraging steel

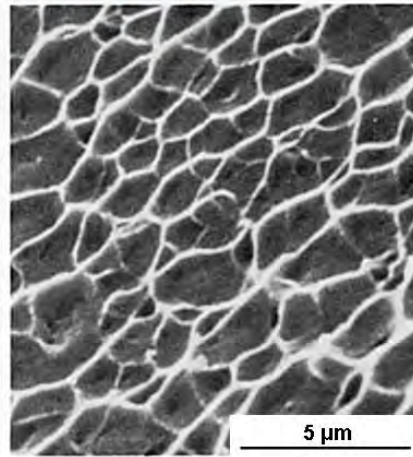

Microductile: Fatigue – I: Optical fractographs of macroscopic and microscopic progression markings (from slide 34)

- Wing spar service failure



Fracture surface progression markings are important for **Quantitative Fractography (QF)** measurements of crack growth (tests and service failures)

- Flight simulation test

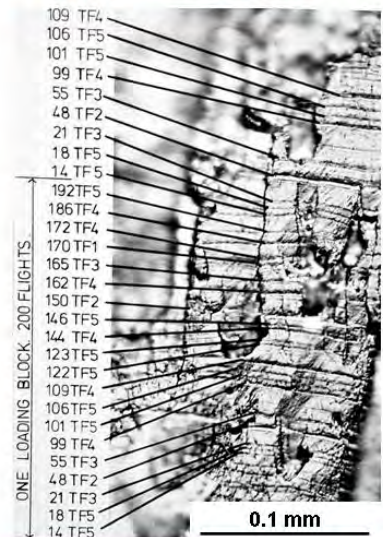

Microductile: Fatigue – II: SEM fractographs of ductile and “brittle” striations on aluminium alloy fracture surfaces



- Ductile striations in 2024-T3 fatigued in laboratory air

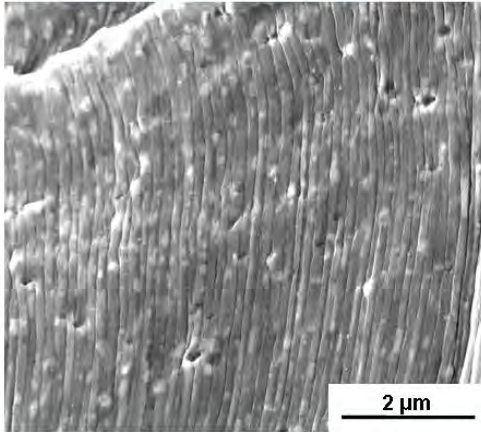

- Brittle striations in 7050-T7451 owing to corrosion fatigue in salt water (*uncommon*)

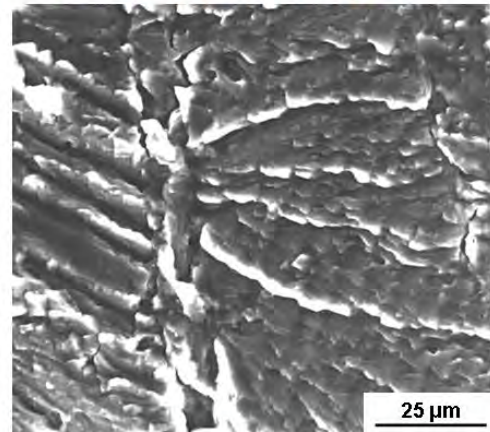

Microductile: Fatigue – III: SEM fractographs of striations on fracture surfaces of some other materials



- Austenitic stainless steel
- Nickel-base superalloy
- Martensitic steel

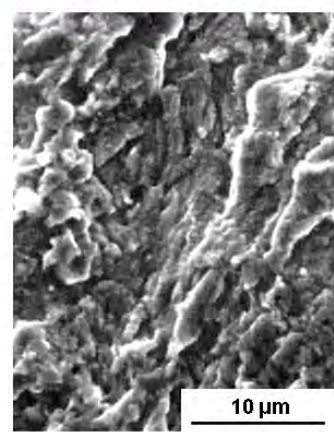
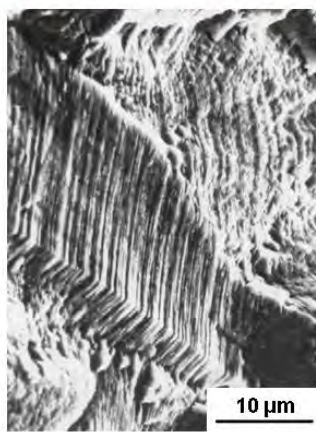

Microductile: Fatigue – IV: Comparison of SEM fractographic and optical metallographic features for a martensitic high-strength steel, 4330V. Note the (typical) absence of striations



- **Microserrated acicular ridges**

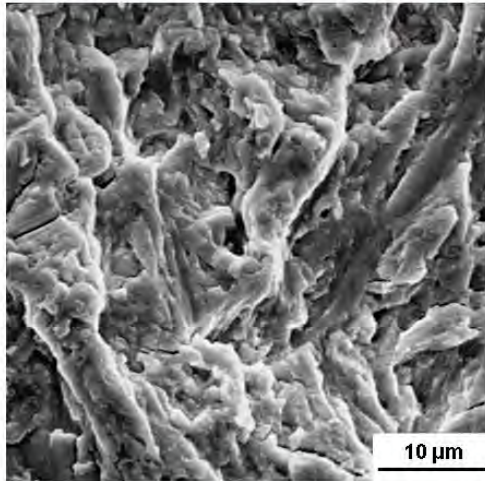

- **Tempered martensite needles**

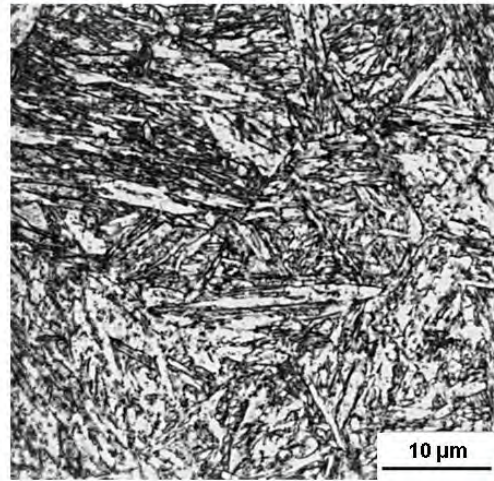

Microductile: Fatigue – V: SEM fractograph/metallograph examples of complex fatigue fracture surfaces



- **Two-phase (primary α + transformed β) titanium alloy, Ti-6Al-4V**

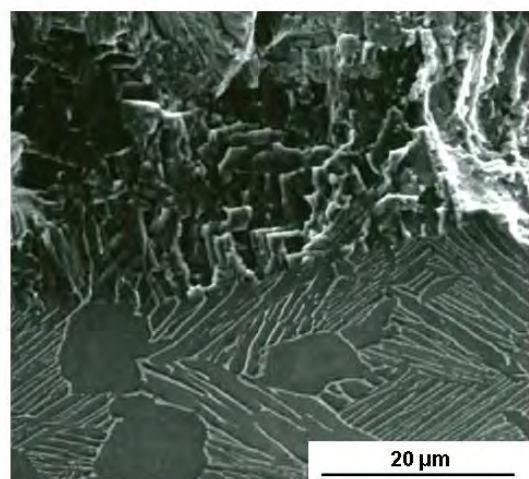
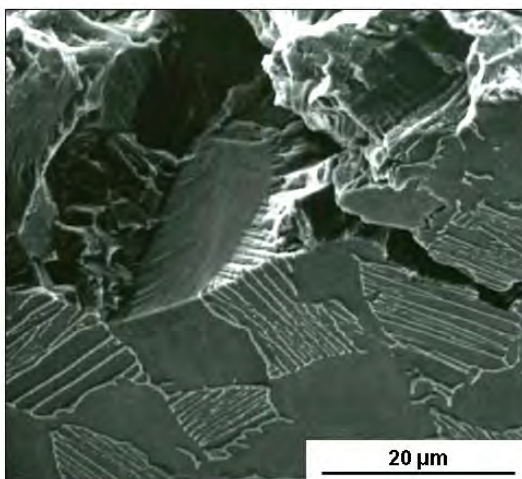



Cautionary Notes – I: Intergranular fracture in high-strength steels

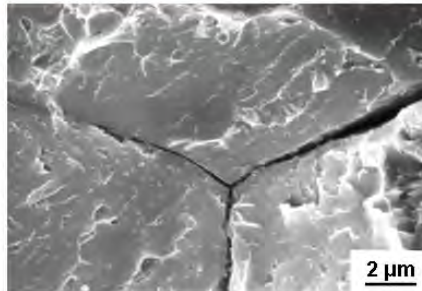

- **Several causes:**
 - hydrogen embrittlement
 - SCC and liquid/solid metal embrittlement
 - segregation/precipitation-induced embrittlement (temper embrittlement)
 - quench cracking
 - corrosion fatigue
 - stress-relief cracking and creep/fatigue cracking at elevated temperatures



Cautionary Notes – II: Confusing fatigue fractures

- **Intergranular fatigue in a Cu-Ni-Al-Fe copper alloy**
- **Stage I faceted fatigue in a nickel-base superalloy**
- **Fatigue in a commercially pure titanium weldment**

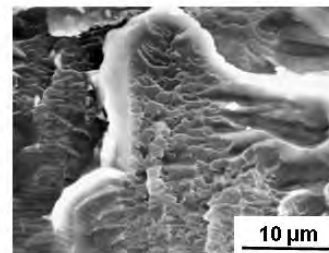
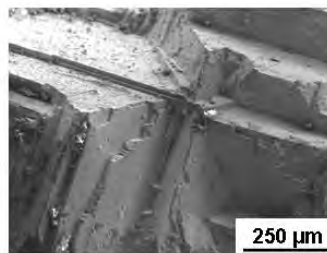
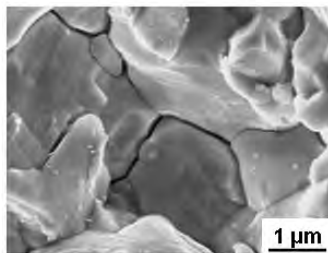

Cautionary Notes – III: Confusing *non-fatigue* fractures



- Crack arrest markings during SCC of copper
- Eutectoid markings from fast fracture of a steel
- Solidification markings and slip lines from fast fracture of an aluminium alloy

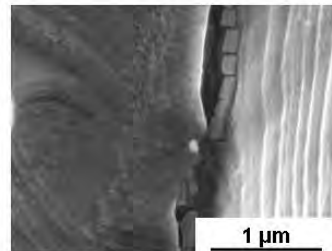
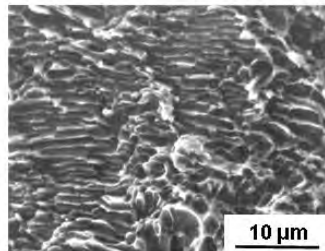
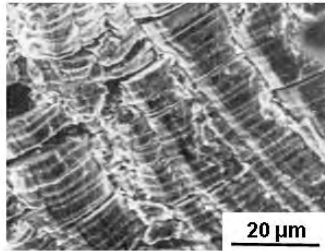

Cautionary Notes – IV: Combinations of fracture modes possible *(~ 8 mm diameter bolt made from tempered martensitic steel)*

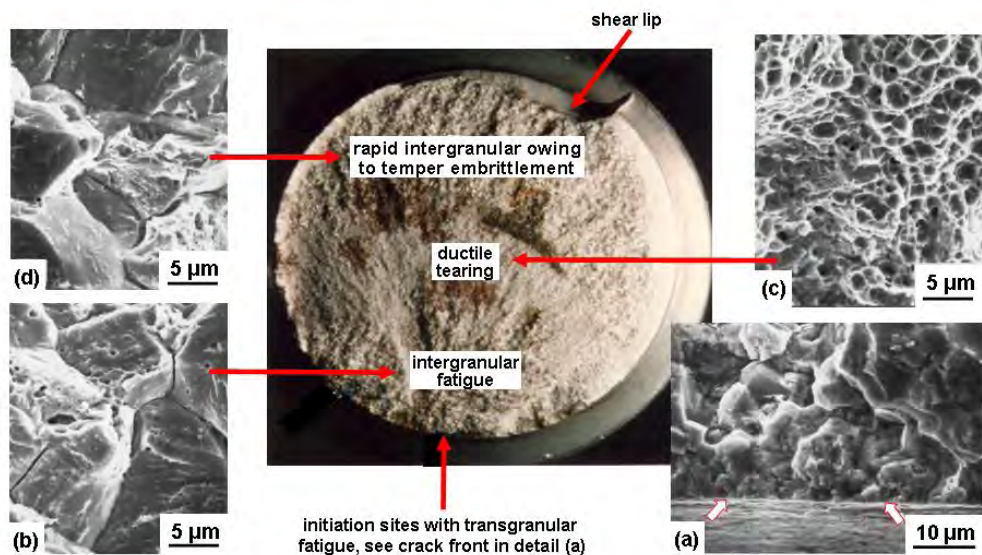

Required Specialist Knowledge and Techniques

9-11-2010 78

Summary of Specialist Knowledge and Technique Requirements

- **Metallurgy and materials:**
 - aluminium, titanium and magnesium alloys, steels, stainless steels, superalloys
 - metallic and non-metallic coatings
 - oils and lubricants; tribology and wear
 - fracture cleaning techniques, chemical analyses, hardness
- **Fractography and metallography**
- **Fatigue and fatigue crack growth analyses**
- **NDI**
- **Mechanical and environmental testing: especially *fatigue* and *tensile* tests**
- **Structural and stress analyses, including Finite Element Analysis**

And.....TEAMWORK!!!

9-11-2010 79

Part II: Case Histories



Case Histories

1



Overview

- Aermacchi MB-326H wing spar (1990)
- General Electric CF6-50 G40 turbine blades (1977-79)
- De Havilland Canada DHC-4 Caribou / Pratt & Whitney R2000 components (1970-84)
- Boeing 747-258F engine + pylon losses (1992)
- Fokker F50 / Pratt & Whitney 125B bearing (2002)
- Aérospatiale Alouette III helicopter tail lug (1990)
- Boeing F/A-18 trailing edge flaps (1993)
- General Dynamics F-16 / Pratt & Whitney F100-PW-220 RCVV lever arm pin (1992)
- Westland Lynx SH14D helicopter rotor hub (1998)

2

Aermacchi MB-326H wing spar (1990)

3

Aircraft: A7-076

- Left wing separation and crash into sea east of Williamtown, NSW



4

Failure of wing spar led to loss of left wing



- Lower spar boom failed adjacent to end of wing attachment fitting during a high-g manoeuvre and at about 70% of the safe life

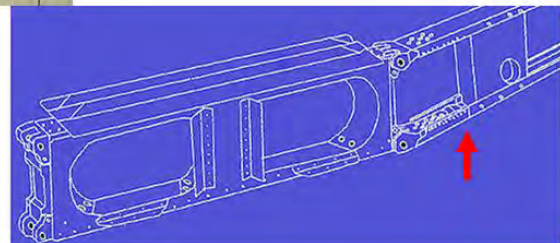

5

Inboard fracture surfaces of lower spar boom, aluminium alloy 7075-T6



Fatigue crack from (very) badly drilled fastener hole

Note fracture surface progression markings. These are important for **Quantitative Fractography (QF)** measurements of crack growth

6

Failed spar boom fatigue crack growth, tracked by correlating progression markings with G-meter data

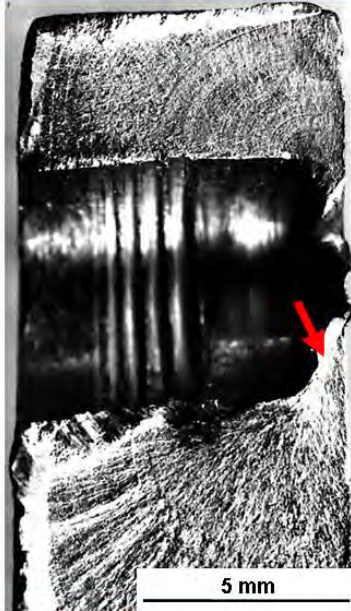

● QF data of crack growth *versus* flight number

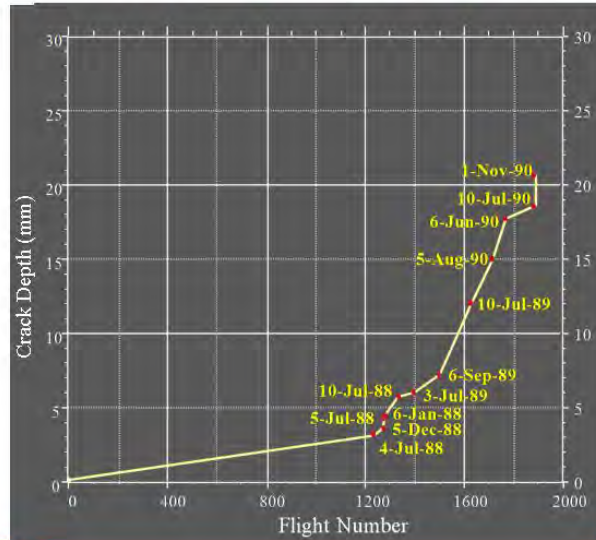

7

Growth of a *right wing* spar boom fatigue crack, tracked by correlating progression markings with G-meter data



● QF had to account for the complication of tensile crack extensions (darker grey areas) due to peak manoeuvre loads. These show up better optically compared to SEM fractographs

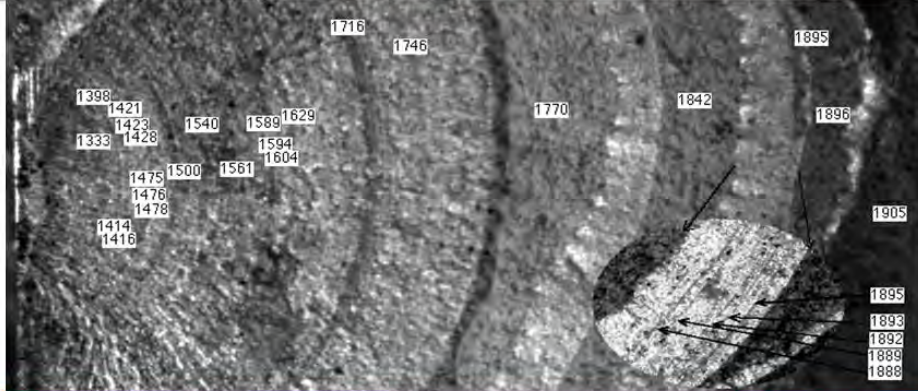

8

QF data plots for the *right wing* spar boom fatigue crack: approximately exponential crack growth

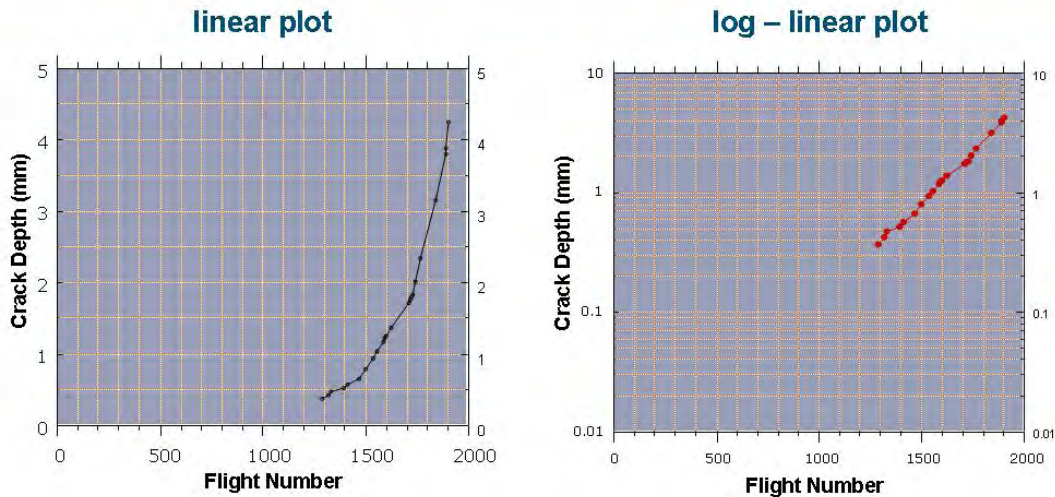

9

Intermediate status of the investigation



- **Physical causes of failure**
 - badly drilled hole → fatigue
 - high local stresses
- **Contributing cause**
 - poor quality control
- **QF evidence for approximately exponential early fatigue crack growth:**

$$a = a_0 e^{\lambda N} \quad \text{and} \quad \ln(a) = \lambda N + \ln(a_0)$$

where a is the crack size at time N , a_0 is the initial crack size, and λ is a constant for a particular load history

10

Further actions (remedial measures)

- **Non-Destructive Inspection (NDI) to detect cracks in fleet wings**
- **Teardown and QF for 9 crack-containing wings**
- **Reassessment of fleet wing lives**
- **Consider options for restoring/maintaining operational capability**
 - wing refurbishments
 - wing replacements
- **Final reassessment of fleet wing lives**

Teardown results for spar cracks

- 103 cracks found from examining about 1000 holes
- Cracks grew approximately exponentially: D17 hole cracks, including the service failure from a severe initial defect, grew faster
- Average trend for all cracks used to reassess fleet wing lives: only 11 out of 69 aircraft fit for service!

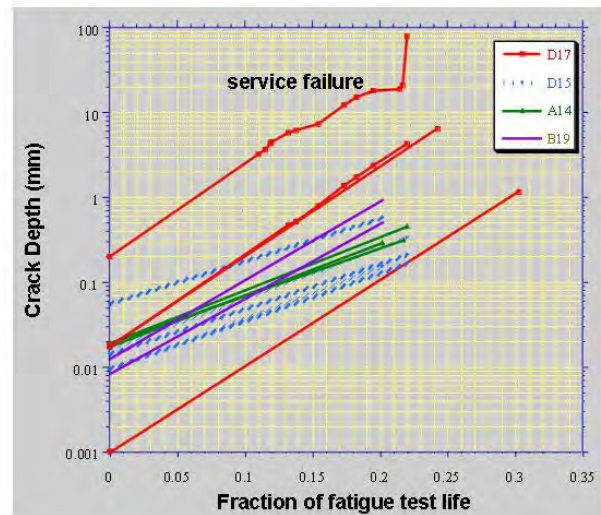

Options for restoring/maintaining operational capability and final reassessment of fleet wing lives



- **Wing refurbishment programme would require**
 - NDI of thousands of fastener holes
 - reaming and fitting oversize fasteners

BUT estimated additional life unsatisfactory: *programme rejected*
- **Wing replacement**
 - buy sufficient wings to allow continued fleet operation
 - 30 new wing sets were purchased
- **Final reassessment of fleet wing lives:**
 - initial quality of 2 crashed 'new' wings showed overall similarity to older wings
 - thus the teardown results could be used to assess the safe lives of new wings

General Electric CF6-50 G40 turbine blades (1977-79)

14

Aircraft *type*: McDonnell Douglas DC-10



15

Engine *type*: General Electric CF6-50



16

Problem: failure of G40 first stage turbine blades
– 18 cases from May 1977 to May 1979

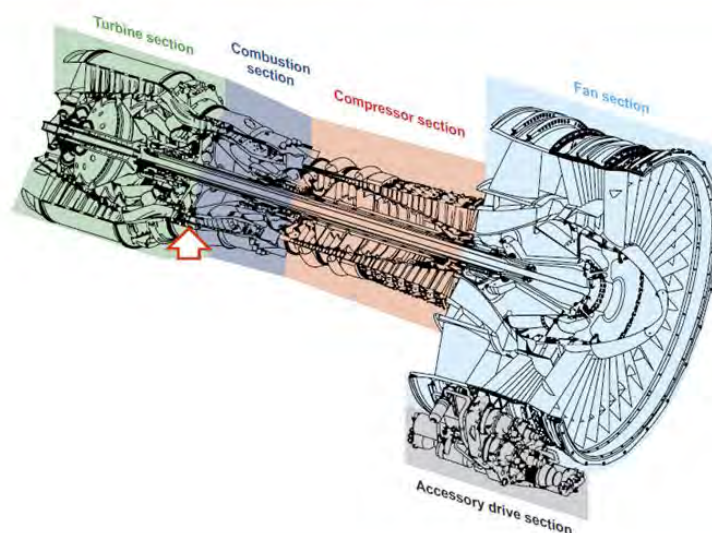

17

Example failure: engine 455-143, 17-05-1978



18

Schematics of typical blade failure and the internal cooling: cast René 80 nickel-base superalloy with a nickel aluminide coating

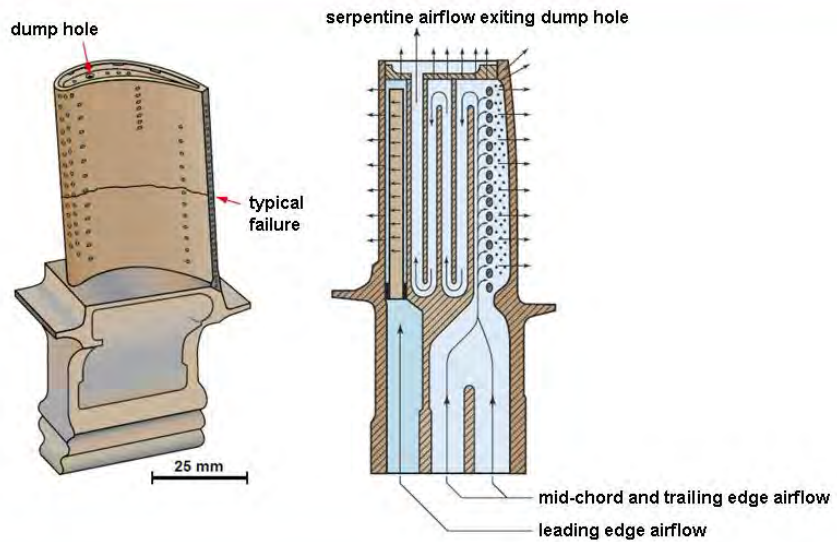

19

Causes of failure (all involved *repaired* blades) and remedial actions



- **Primary causes**

- acid strip old coating → cooling hole enlargement → *ineffective* leading edge airflow (reduced pressure)
- ceramic core shift during casting → *thin* leading edge convex walls
- dump hole braze overcorrecting increased (beyond limits) serpentine airflow



Increased stresses and reduced Low-Cycle Fatigue (LCF) + High-Cycle Fatigue (HCF) lives

- **Contributing causes**

- specified wall thickness check *non-operative*
- engine uprating (increased stresses)

- **Remedial actions**

- improved lifing procedure (temporary)
- new blade design

De Havilland Canada DHC-4 Caribou/Pratt & Whitney R2000 components (1970-84)

21

Aircraft *type*: De Havilland Canada DHC-4 Caribou



22

Engine type: Pratt & Whitney R2000

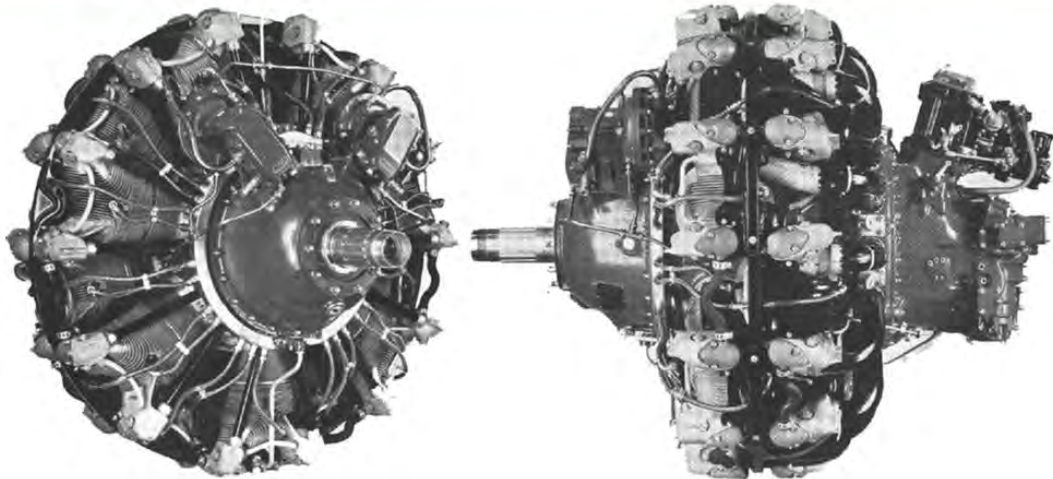

23

Problem: 17 engine failures over 14 years, 1970-1984



- All engine failures examined from 1970 to 1984 by overhaul subcontractor
- Many failures attributed to link rod fatigue, **BUT** no detailed investigations. These would have been complicated, owing to extensive break-up of the components (martensitic high-strength steels, mainly 4340):
 - pistons broken and/or jammed in cylinders
 - link rods and master rods fractured into many pieces
 - most piston pins broken
- Scope of DSTO detailed investigation in 1984:
 - link rods
 - piston pins
 - master rods
 - wrist pins

24



Examples of failed components – I: failed engines

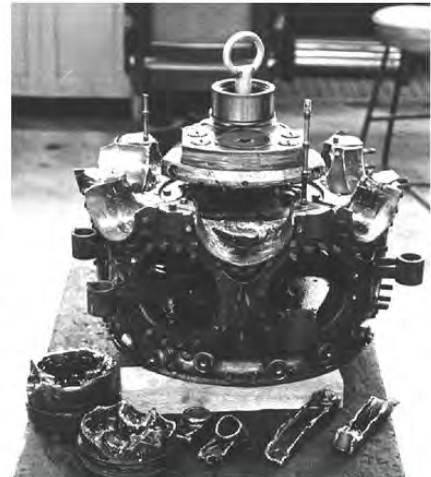
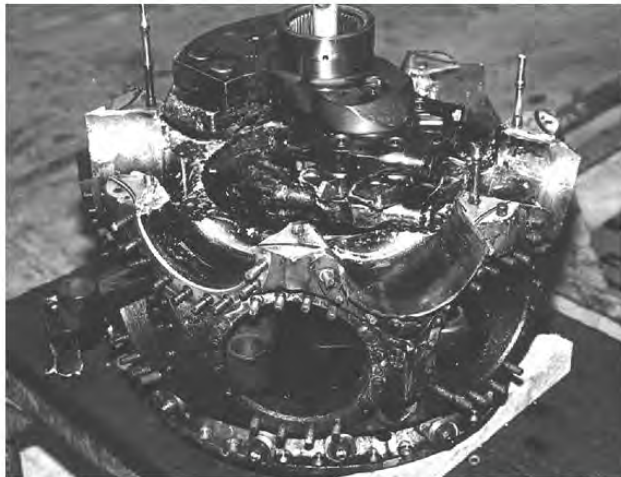

25



Examples of failed components – II: link rods

- Link rod failed by rapid fatigue crack growth: initiation sites arrowed

- Several engines failed with only one broken link rod and no fatigue

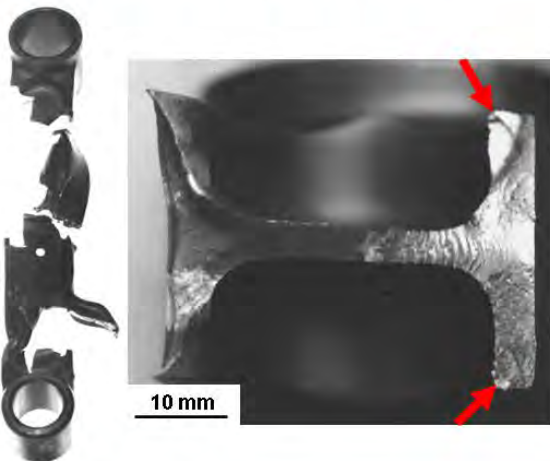

26

Examples of failed components – III: piston pin



- Longitudinal fatigue cracking from the inside, with change to roughly circumferential direction, running round the pin upon reaching the outer surface



27

Examples of failed components – IV: master rod

- One engine failure caused by fatigue of a master rod
- Progression markings indicated that fatigue cracking began after overhaul only 25 service hours earlier
- No associated failures of piston pins or wrist pins

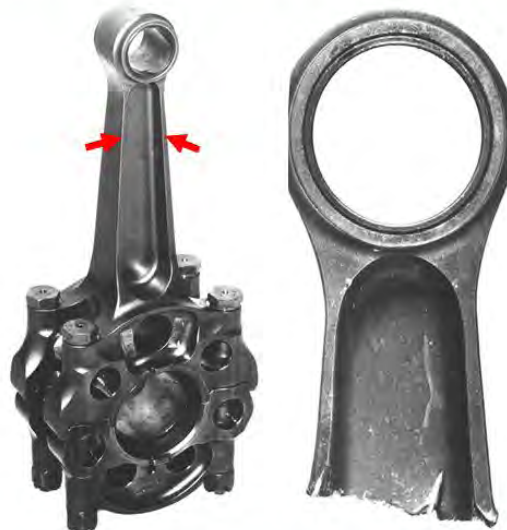

28

Causes of failure and remedial actions

- **Physical causes determined by DSTO**

- link rods: excessive (cumulative) shot-peening of rod edges and bad reaming
- piston pins: substandard material (large MnS particles)
- wrist pins: poor heat-treatment practice (oxide intrusions and decarburization); poor electroplating practice (arc burn)
- master rod: probable excessive shot-peening

- **Contributing causes**

- lack of quality control during overhaul
- *delay in instigating detailed investigations*

- **Remedial actions**

- avoidance of shot-peening at each overhaul
- use of P&W approved material for piston pins
- improved processing quality during overhauls

Boeing 747-258F engine + pylon losses (1992)

30

Aircraft: 4X-AXG



31

Last flight of EL AL 1862: October 4, 1992

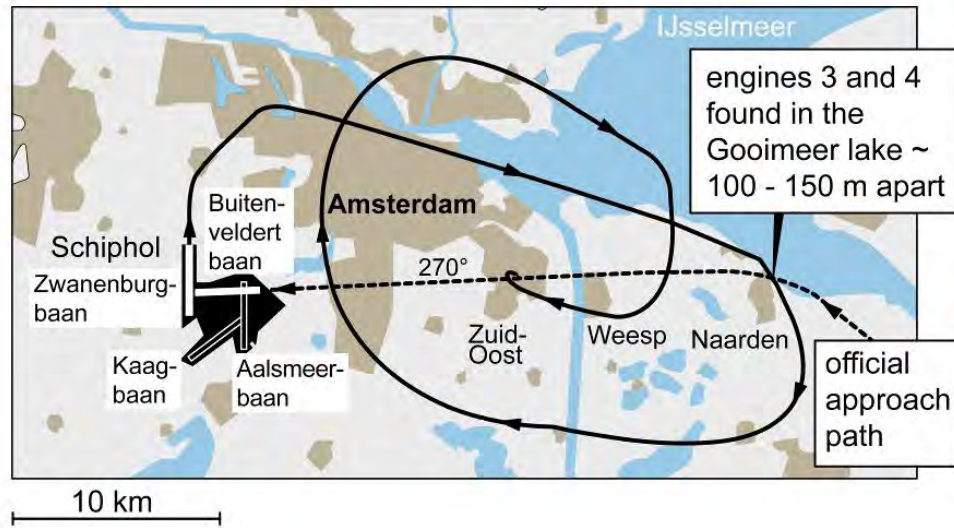

In-flight final situation

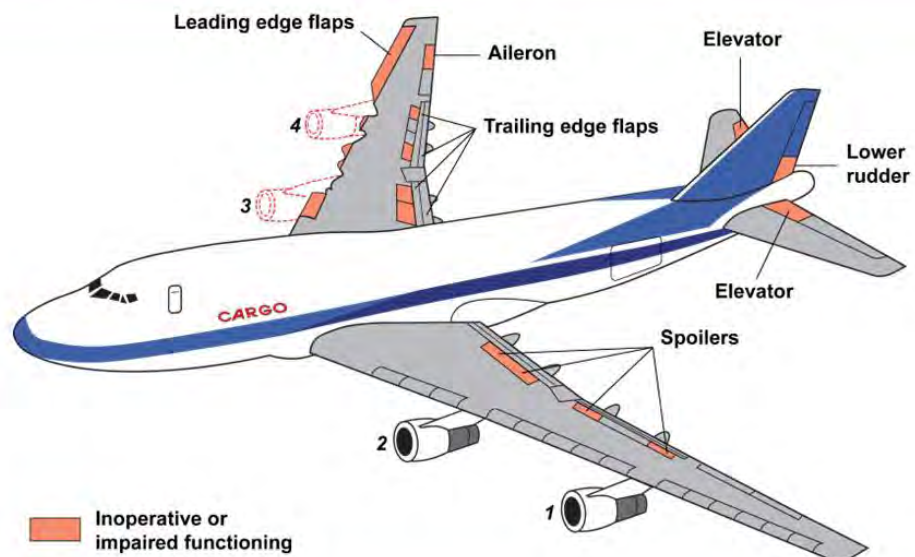

Crash into apartment blocks, 04-10-1992



34

Some of the wreckage, including engines 3 and 4, recovered from the Gooimeer lake

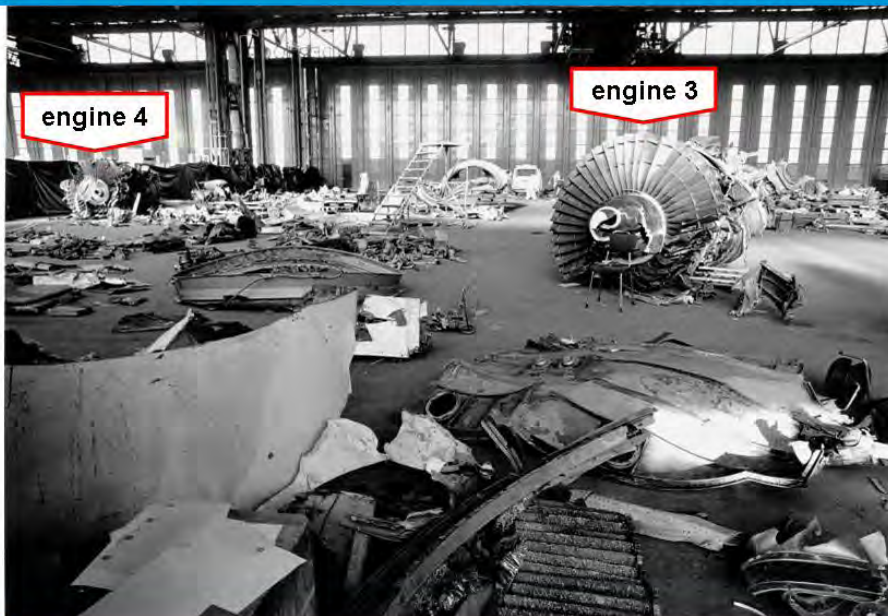

35

Recovered components from engine 3 pylon-to-wing connections

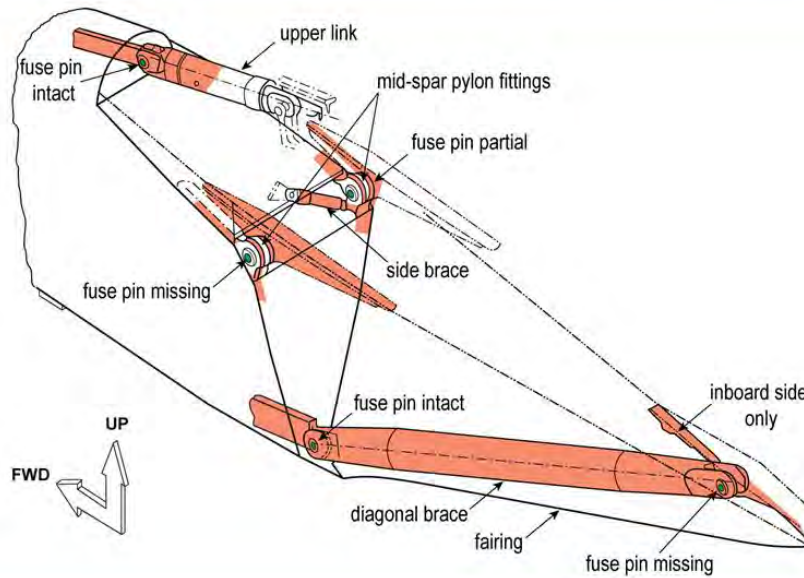

36

Engine 3 mid-spar pylon fittings: martensitic high-strength steel 4330M (220-240 ksi)

Inboard



- Inner lug bent
- Outer lug failed by tensile + bending overload

Outboard



- Scraping in lug throat

37

Engine 3 outboard mid-spar fuse pin schematic and remnant: medium-strength steel 4330M (126-139 ksi)

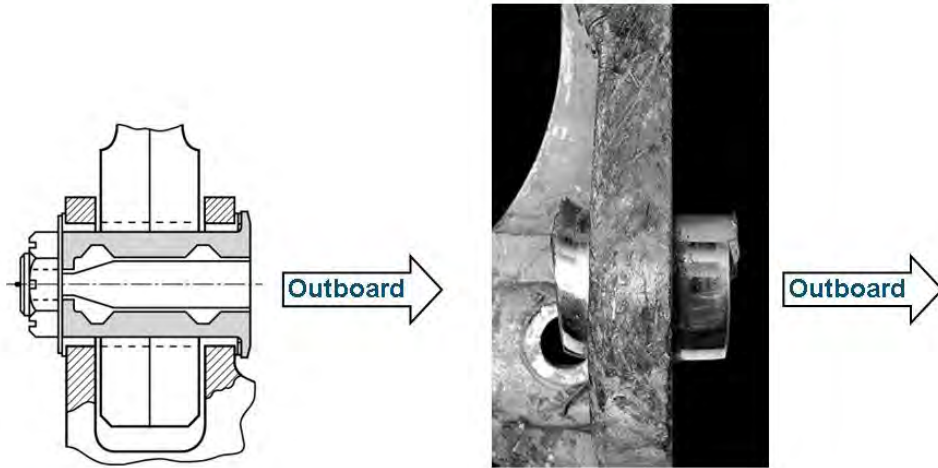

38

Engine 3 outboard mid-spar fuse pin outer fracture surface: medium-strength steel 4330M (126-139 ksi)

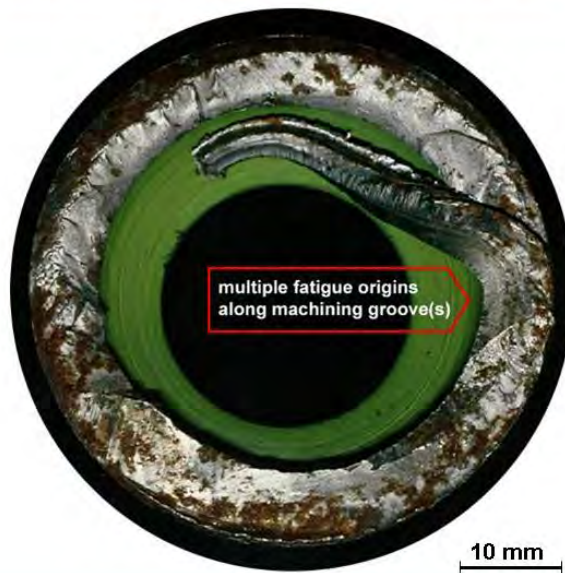

39

Most probable separation sequence for engine 3 and pylon

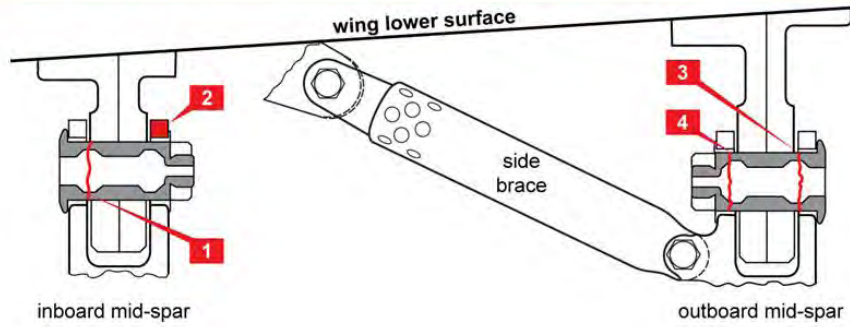

- **Inboard failure**
 - (1) Fatigue + overload of fuse pin inner thin-walled location
 - (2) Overload of outer lug
- **Outboard failure**
 - (3) Overload of already fatigue cracked fuse pin outer thin-walled location
 - (4) Overload of fuse pin inner thin-walled location

Separation of engines 3 and 4

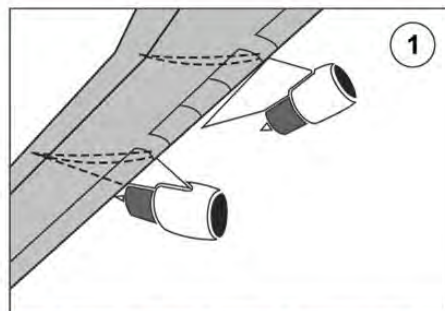

● Engine 3 and pylon separation

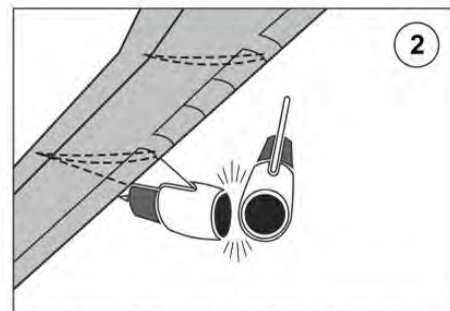

● Engine 3 collision with engine 4

- Both engines and pylons fell into the Gooimeer lake (see slide 32)

Causes of failure

- **Primary cause: high local dynamic stresses → fatigue of fuse pins**
- **Contributing causes**
 - inadequate knowledge of dynamic loads on engine pylons
 - fuse pin design → internal machining grooves → local stress concentrations
 - fuse pin non-classical “crankshaft” bending under service loads → increased stress concentrations at thin-walled locations

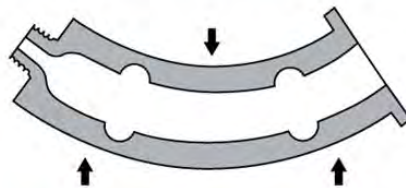

● classical bending analysis

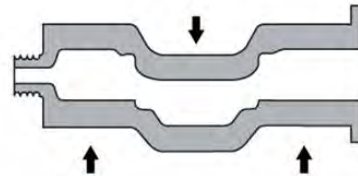

● Boeing Finite Element Analysis: “crankshaft” bending

Remedial actions

- **New design fuse pin without thin-walled locations**
- **Two extra connections between mid-spar pylon fittings**
- **Larger mid-spar pylon fittings and stronger diagonal brace and upper link**

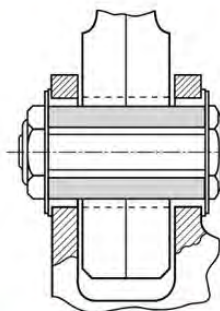

● new fuse pin design

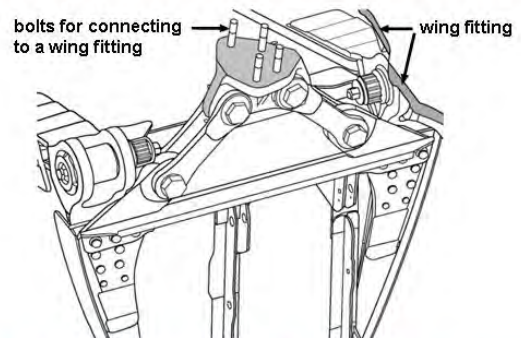

● new mid-spar pylon connections

Postscript - I: fuse pin fatigue fracture surface

- Stereo pair SEM fractographs of rubbed and smeared fatigue striations with spacings suggesting crack growth rates greater than 1 $\mu\text{m}/\text{cycle}$

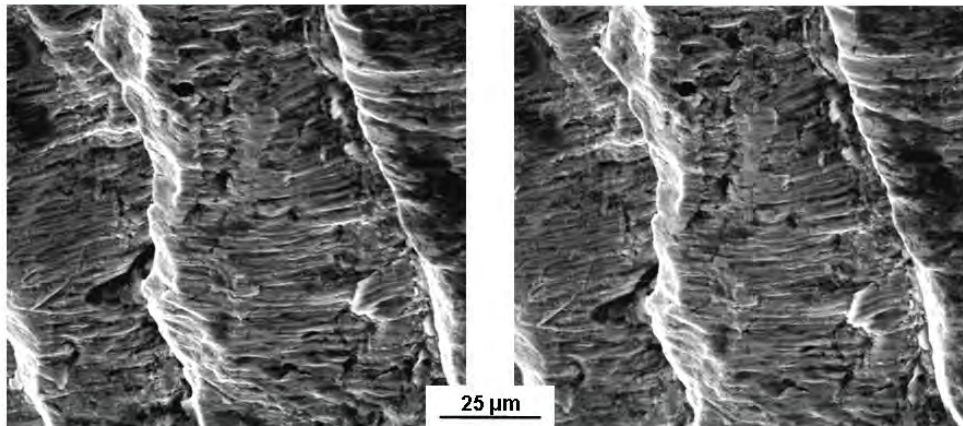

44

Postscript - II: “fuse pin” fatigue fracture surface

- The OEM suggested that the large striations in slide 44 represent only the large striations shown opposite
- This implied that
 - on a cycle-by-cycle basis the crack growth in the fuse pin remnant was much slower than a striation count from slide 44 would indicate
 - the aircraft operator should therefore have detected the cracked fuse pin before failure
- However, the fractograph shown here is for 2024-T3 aluminium alloy and was published already in 1967*

* J.C. McMillan and R.M.N. Pelloux, in: *Fatigue Crack Propagation, ASTM STP 415*, American Society for Testing and Materials, Philadelphia, 1967, pp. 505-532

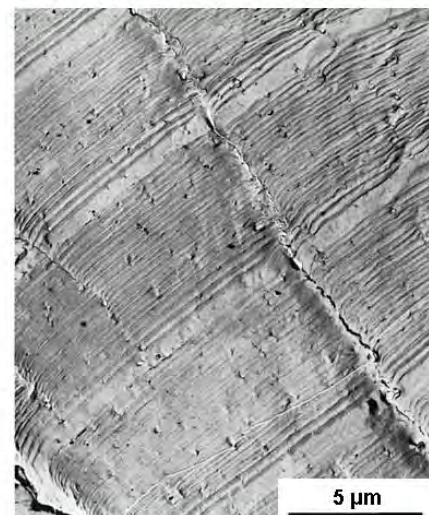

45

Fokker F50 / Pratt & Whitney 125B bearing (2002)

46

Aircraft type: Fokker F50



47

Engine type: Pratt & Whitney 125B 

- Problem: No.2 engine torque indication dropped to zero and flight aborted

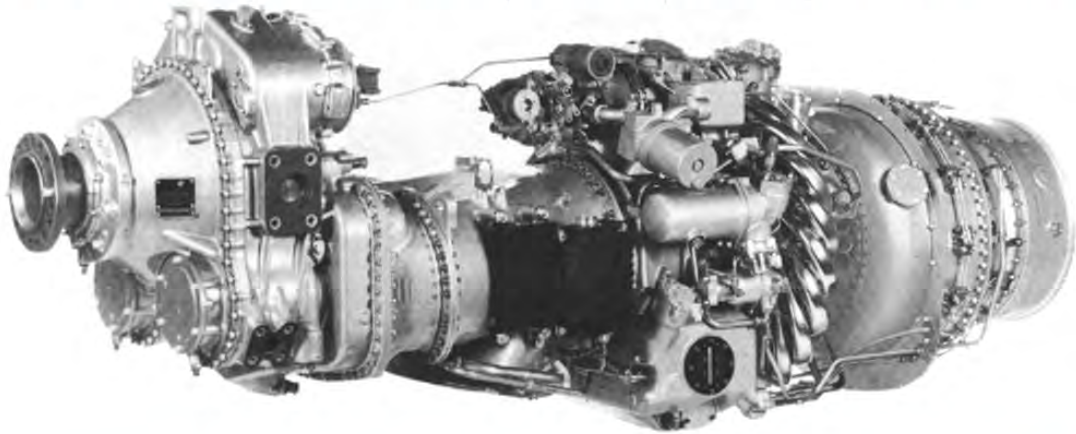

48

Partially disassembled No.3 bearing from the No.2 engine 

- Investigation showed the bearing had failed, with extensive secondary damage: *engine internally destroyed*



49

Disassembled bearing – I: outer race and cage



- 5095 hrs (6425 engine starts) since new and 530 hrs (585 engine starts) since overhaul
- Cage failure resulted in contact with the outer race and overheating

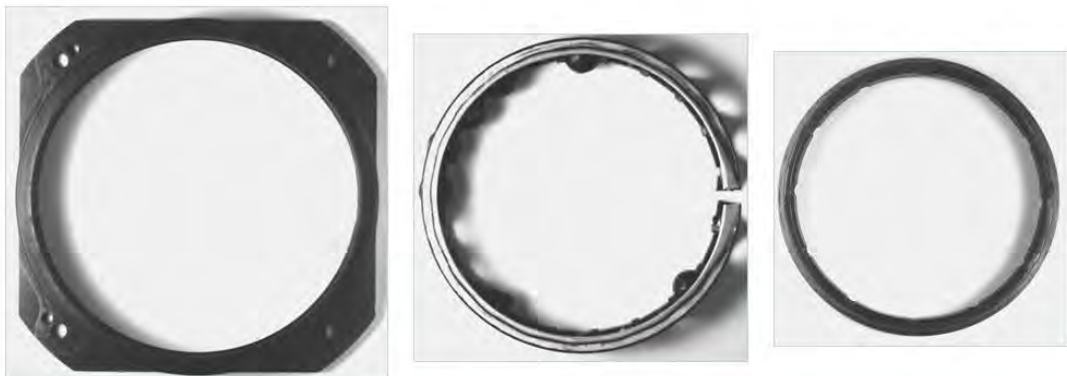

Disassembled bearing – II: ball bearings, M 50 steel



- 19 of the 20 balls were damaged by overheating, deformation, wear and cracking
- One ball was relatively undamaged and about 1 mm undersize



Cage failure details – I: macroscopic observations

- The ball pocket at the cage failure position was considerably elongated
- This pocket had contained the undersized ball



52

Cage failure details – I: optical fractographic overview

- The cage failed by high cycle – low stress fatigue
- Progression markings suggested engine starts

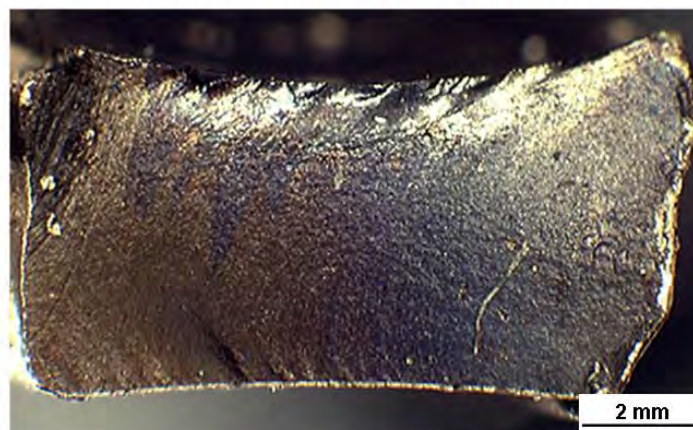

53

Cage failure details – II: Quantitative fractography (QF) results for the progression markings

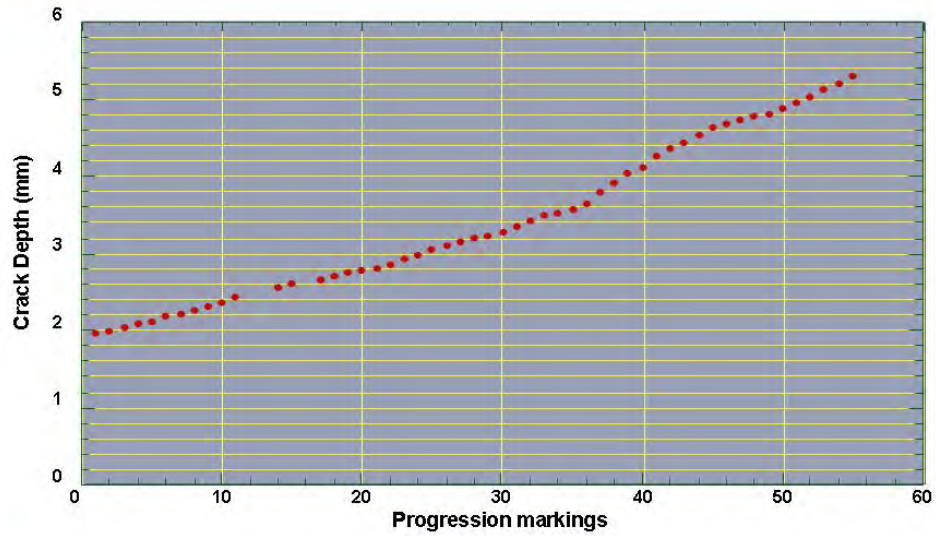



54

Cage failure details – III: QF suggested exponential crack growth ($a = a_0 e^{\lambda N}$ and $\ln(a) = \lambda N + \ln(a_0)$)

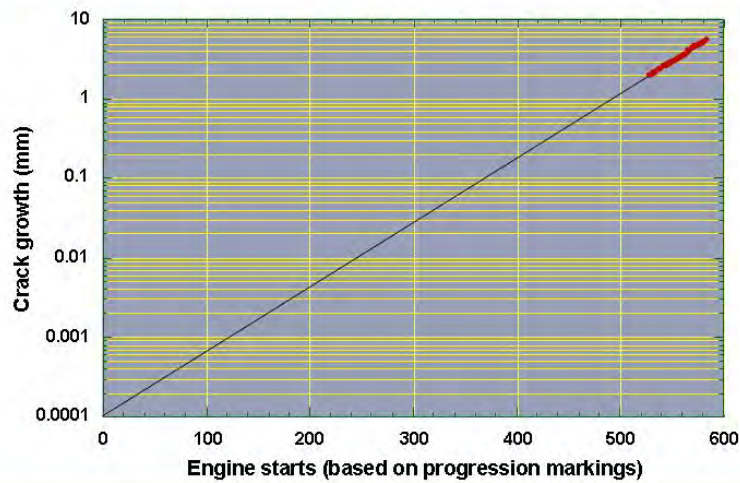

- Extrapolation to extremely small initial crack size, a_0 , gave an estimated crack growth life less than 600 engine starts:



55

Causes of failure and remedial action

- **Physical cause: undersize ball**
 - put into the race *during the previous overhaul*
 - unable to take loads, causing abnormal loads on adjacent balls and cage
- ↓
- fatigue in the cage ligaments on either side of the ball
 - cage failure and expansion to rub on the outer race
 - rubbing-induced overheating, causing lubrication loss and bearing failure
- **Remedial action: install new engine**

56

Postscript: the undersized ball

- **The OEM stated that:**

“The small ball is actually a correctly sized ball that had worn down to its present size through misuse during service.” (!)

57

Aérospatiale Alouette III helicopter tail lug (1990)

58

Aircraft: A-351, member of Grasshoppers Demonstration Team



59

A-351 airframe wreckage after tail loss



60

A-351 tail after in-flight separation



61

Lug fracture: medium-carbon steel plate, 01-10-1990

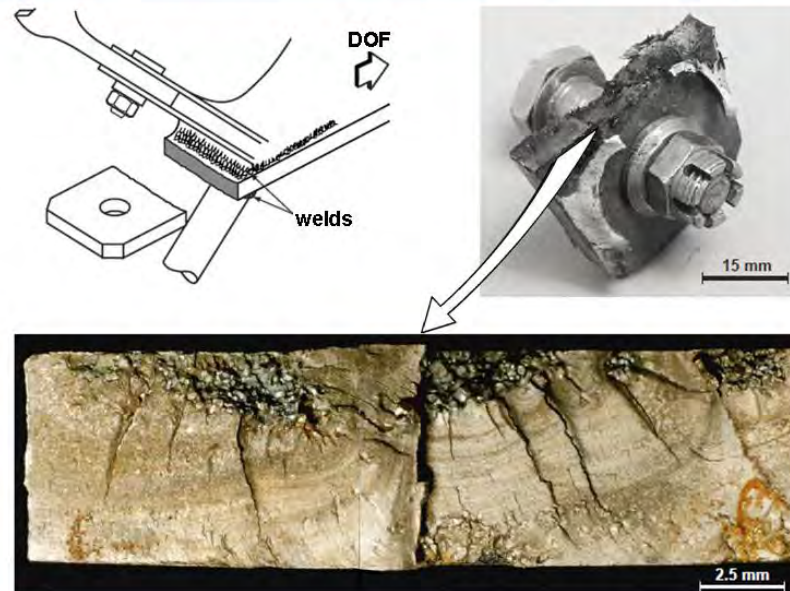

62

Causes of failure and remedial actions

- **Failure sequence:** overheating during welding → (Mn+Fe)S melting + liquation along grain boundaries → liquation (intergranular) cracking → fatigue
- **Primary cause:** lug was 0.4% C steel with higher C and S content than *specified* 0.2 – 0.3% C steel
 - more difficult to weld (higher C content)
 - increased risk of liquation cracking (higher S content)
- **Remedial actions**
 - chemical analysis of lugs from remaining fleet (66) → one other 0.4% C lug
 - rework body structure of aircraft concerned

63

Boeing F/A-18 trailing edge flaps (1993)

64

Aircraft type: Boeing F/A-18



65

F/A-18 incident aircraft, A21-009, July 1993 near Williamtown, NSW

- **RH trailing edge flap (TEF) lost during manoeuvre**
- **Substantial additional damage to aircraft:**
 - flap shroud lost
 - leading edges of vertical tails broken off
 - holes punched in dorsal deck, LH TEF and LH horizontal stabilizer
- **Safety-of-flight matter: high landing speed required**

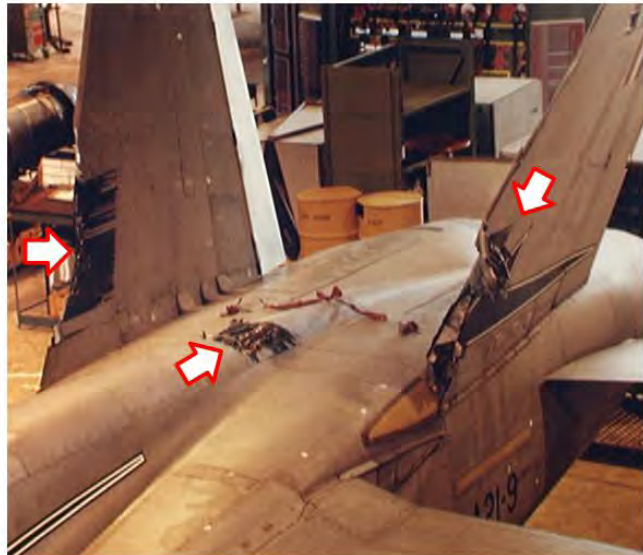

TEF configuration

- **The TEF is a large part of the rear edge of the wing**
- **The TEF is hinged at two points and moves on tracks that are part of a shroud which covers the wing-to TEF connection**

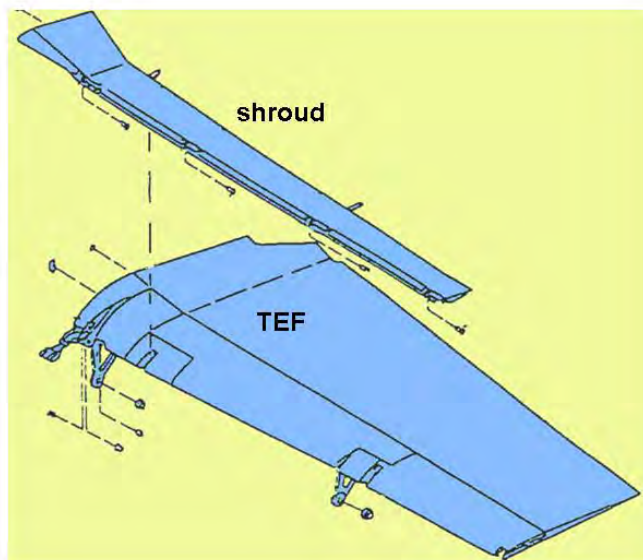

Scope of DSTO investigation

- Examination of TEF hinge remnants from the incident aircraft, A21-009, and cracked lugs from A21-015 and A21-021: aluminium alloy 7050-T7451
 - causes of failure and cracking
- Quantitative Fractography (QF) of TEF hinge lug cracking
- Assessment of Non-Destructive Inspection (NDI) detectable crack growth life and inspection intervals
- NDI development to improve detectable crack growth life and increase inspection intervals
- Corrosion protection improvement
- Follow-up

68

Examination of TEF hinges - I: A hinge lug + monoball bearing; and the bearing from the A21-009 failed lug

- A hinge lug and bearing showing deterioration of the corrosion protection system
- A21-009 monoball bearing outer surface with marking suggesting extent of sub-critical cracking just before lug failure

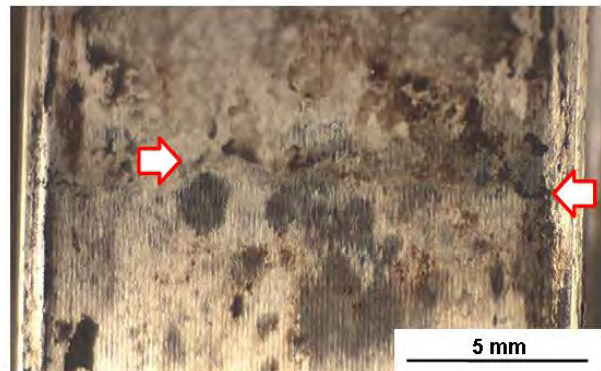

69

Examination of TEF hinges - II: Cracked hinge lugs from aircraft A21-015 and A21-021



- All high-life RAAF flaps were inspected after the TEF failure on aircraft A21-009
- The OEM-specified eddy current NDI method was used to inspect around the monoball bearing
- Inspection found two flaps with hinge lug cracking, on aircraft A21-015 (1377 flight hours) and A21-021 (1369 flight hours)
- The cracks were broken open and found to be fatigue
 - initiating primarily on the bevelled inner radii of the lugs, slide 71
 - showing fracture surface progression markings, slide 72
- Primary and secondary fatigue cracks initiated from corrosion pits, slide 73

70

Optical fractographs of the NDI-detected TEF hinge lug cracks



- A21-015 cracks (both sides of lug)

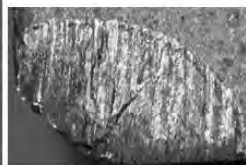
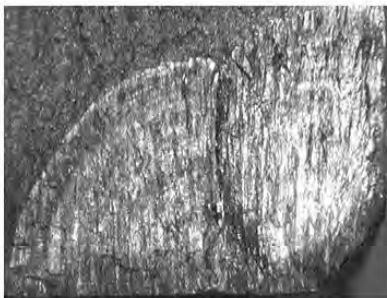

- A21-021 crack



2 mm

71

SEM fractographs of the larger fatigue fracture surface from the A21-015 TEF hinge lug



- Well-defined progression markings evident on the fatigue fracture surface

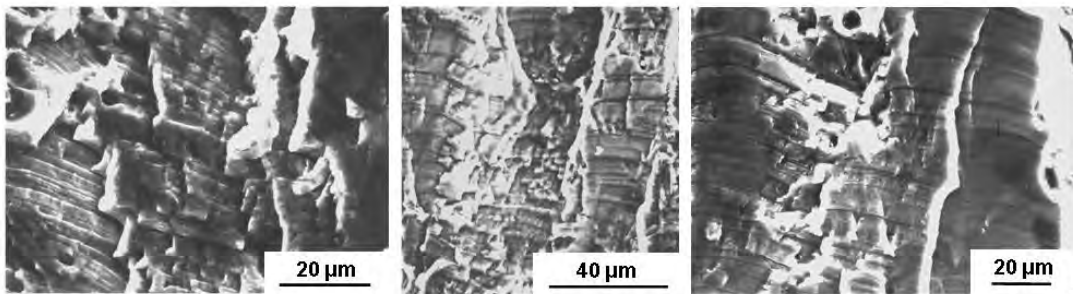

72

Optical metallographs of secondary fatigue cracks initiating from corrosion pits on the A21-015 TEF hinge lug



- Corrosion pit growth influenced by fatigue: probable corrosion fatigue to crack depths ~ 0.1 mm. Arrows point to fatigue cracks

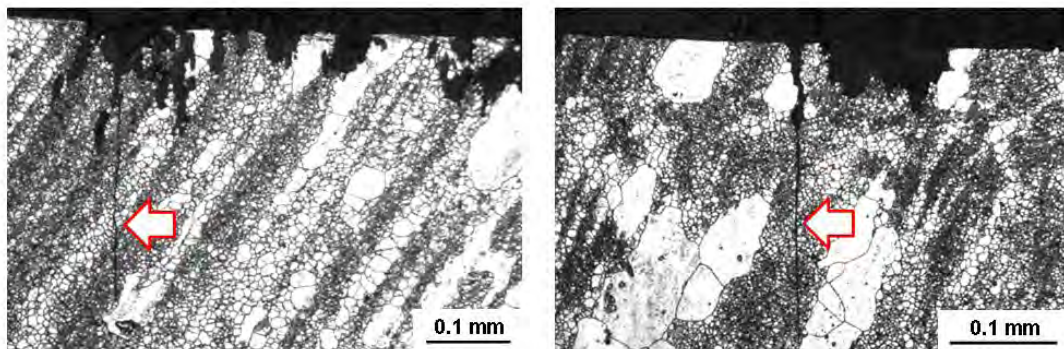

73

Causes of failure and cracking of the TEF hinge lugs

- **Primary cause of failure and cracking**
 - corrosion pitting and limited corrosion fatigue → fatigue
- **Contributing causes**
 - deterioration of the corrosion protection system
 - pitting corrosion susceptibility of aluminium alloy 7050-T7451*
 - probably high local stresses, partly due to non-uniform cold expansion of the lug during manufacture (intended to *enhance* the fatigue life)

* R.J.H. Wanhill, NLR TP 94177, National Aerospace Laboratory, Amsterdam

74

Further actions (remedial measures)

- QF for the A21-015 and A21-021 TEF hinge lug cracks
- Assessment of detectable crack growth life and inspection intervals using the OEM-specified NDI method
- NDI development by DSTO to improve detectable crack growth life and increase inspection intervals
- Corrosion protection improvement
- Follow-up

75

**QF for the A21-015 and A21-021 hinge lugs - I:
Initial information, assumption and procedure**



- No known load history for TEFs
- Assume a linear relationship between progression markings (events) and flight hours, **BUT** no assumption of events per flight hour
- Plot surface crack lengths (normal to lug bores) *versus* events
 - linear – linear
 - log – linear, to check for approximately exponential fatigue crack growth

$$a = a_0 e^{\lambda N} \quad \text{and} \quad \ln(a) = \lambda N + \ln(a_0)$$

where a is the crack size at time N , a_0 is the initial crack size, and λ is a constant for a particular load history

**QF for the A21-015 and A21-021 hinge lugs - II:
Linear – linear plot of crack lengths *versus* events**

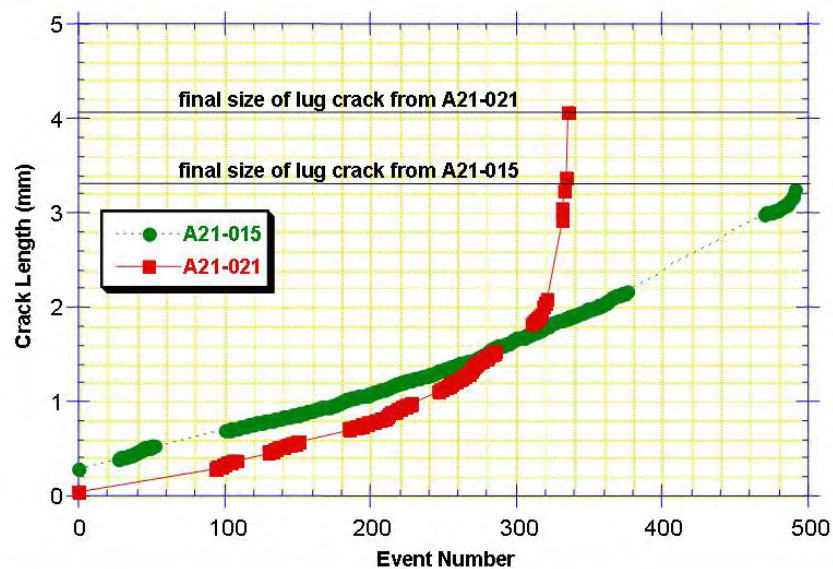

QF for the A21-015 and A21-021 hinge lugs - III: Log – linear plot of crack lengths *versus* events

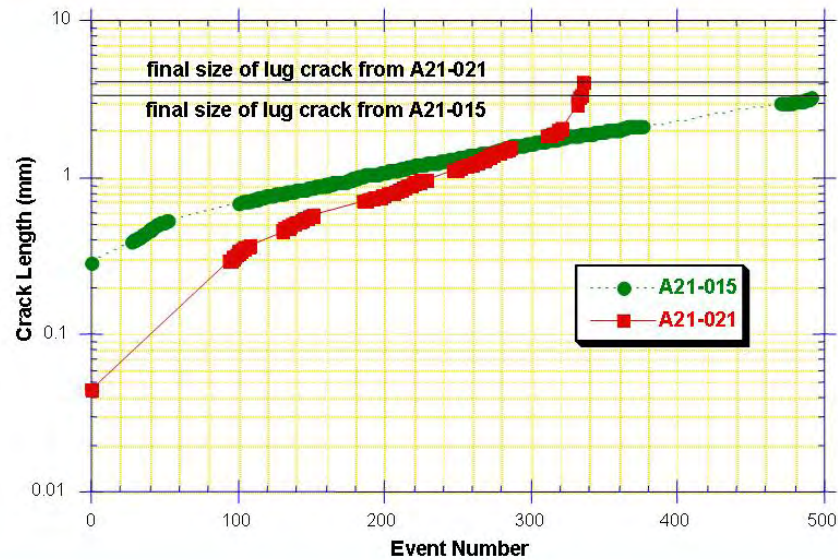

78

Assessment of detectable crack growth life and inspection intervals using the OEM-specified NDI method - I : Overview



● Procedure

- use the approximately exponential fatigue crack growth plot for the A21-015 TEF hinge lug crack. This allows forward-extrapolation to the critical crack size at failure and back-extrapolation to a reasonable initial crack size
- select the initial and critical crack sizes and extrapolate the fatigue crack growth plot
- add the NDI-detectable crack size to the extrapolated plot
- estimate the detectable crack growth life in terms of *events*

● Assume

- immediate crack growth from the initial crack size (conservative)
- total number of *events* represents total *flight hours*

- Estimate the detectable crack growth life in terms of flight hours and divide by 2 to obtain the NDI inspection interval

79

Assessment of detectable crack growth life and inspection intervals using the OEM-specified NDI method - II : Initial and critical crack sizes



- Initial crack size assumed to be 0.1 mm. This is based on secondary cracks, e.g. slide 73
- Critical crack size derived from
 - (a) The marking on the A21-009 monoball bearing, see slide 69. This suggests a crack depth (along the bore) of 9 mm when the lug failed
 - (b) From the profile of the largest crack in the A21-015 lug, see slide 71, a critical crack depth of 9 mm corresponds to a critical crack length of 6.2 mm. This is shown in the schematic

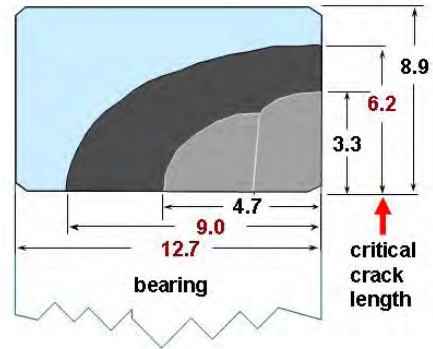

Assessment of detectable crack growth life and inspection intervals using the OEM-specified NDI method - III : Fatigue crack growth lives and inspection intervals



- Total crack growth life ~ 1060 events
- Detectable crack growth life ~ 160 events
- Assume 1060 events = 1377 flight hours, see slide 70.
- Then the detectable crack growth life is 208 flight hours and the inspection interval is ~ 100 hours
- This inspection interval is too short for service applications

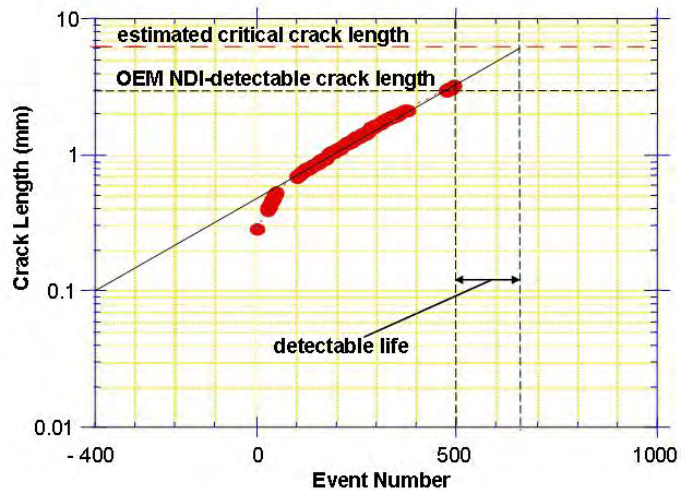

NDI development to improve detectable crack growth life and increase inspection intervals – I: Summary of results



- **OEM eddy current NDI required unacceptably short inspection intervals**
 - NDI-detectable minimum crack length 3 mm
 - inspection interval ~ 100 hours

- **DSTO developed an ultrasonics NDI method to *supplement* the OEM inspection method**
 - NDI-detectable minimum crack length 1 mm
 - supplemental because it covers most but not all of the lug bore

- **Detectable crack growth life and inspection intervals much increased, see slide 83**

82

Improvement of detectable crack growth life and inspection intervals using the DSTO NDI method



- Detectable crack growth life ~ 480 events
- Assume 1060 events = 1377 flight hours, as before
- Then the detectable crack growth life is 624 flight hours and the inspection interval is ~ 300 hours
- DSTO NDI method now used as supplementary inspection for TEFs on RAAF aircraft

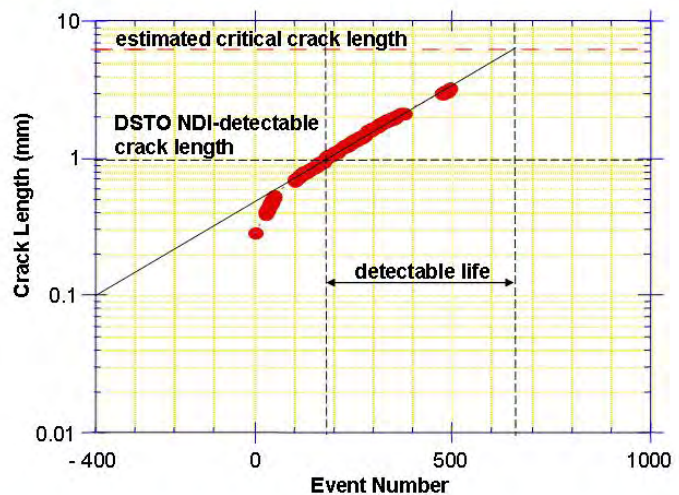

83

Corrosion protection improvement for the monoball bearing and TEF hinge lug assembly



- Inspect lugs for corrosion
- Chemically remove corrosion products
- Re-inspect for cracking
- Reapply chemical conversion coating
- Wet set monoball bearing
- Improve sealant around edges of bearing

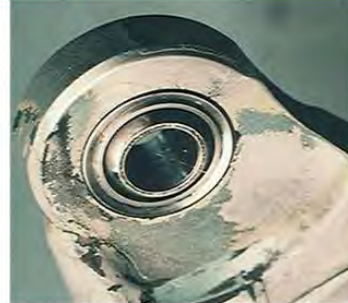

84

Follow-up



- TEFs have been lost in the USA and Canada
- A recovered flap confirmed the hinge lug fracture location
- Critical crack size was 6 mm (DSTO estimate was 6.2 mm)
- The Canadian TEF had just been inspected with the OEM-specified NDI method!
- RAAF reliance only on the OEM-specified NDI method would have resulted in reduced availability and possible loss of aircraft

85

General Dynamics F-16 / Pratt & Whitney F100-PW-220 RCVV lever arm pin (1992)

86

Aircraft: J-054



87

Crash between housing blocks after engine failure, 11-02-1992



Engine type (Pratt & Whitney F100-PW-220) and problem location

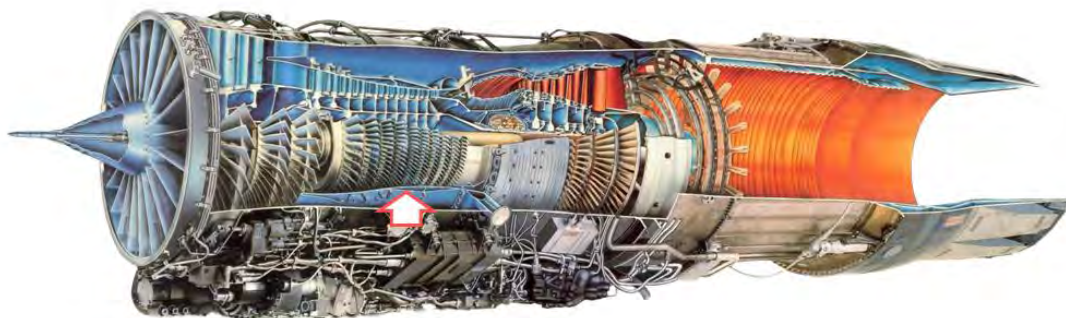

Rear Compressor Variable Vane (RCVV) lever arm assembly: malfunction due to pin fracture

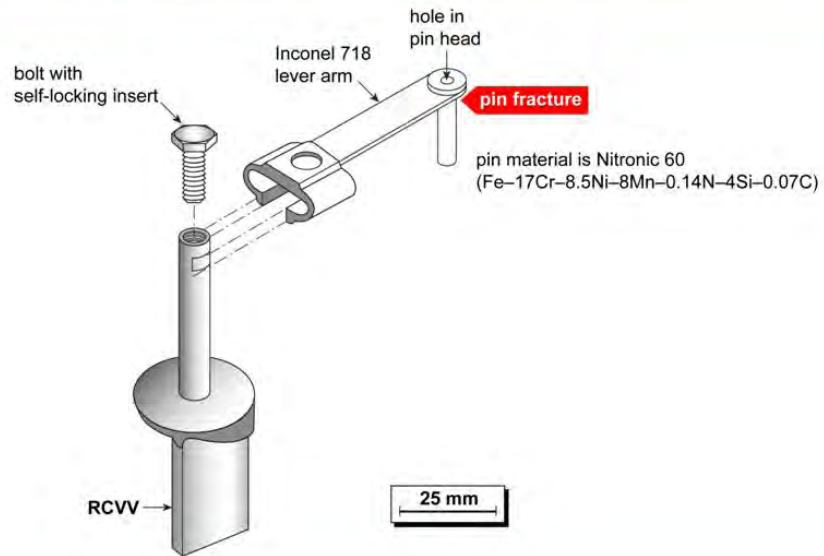

90

As-received fracture surface of lever arm pin

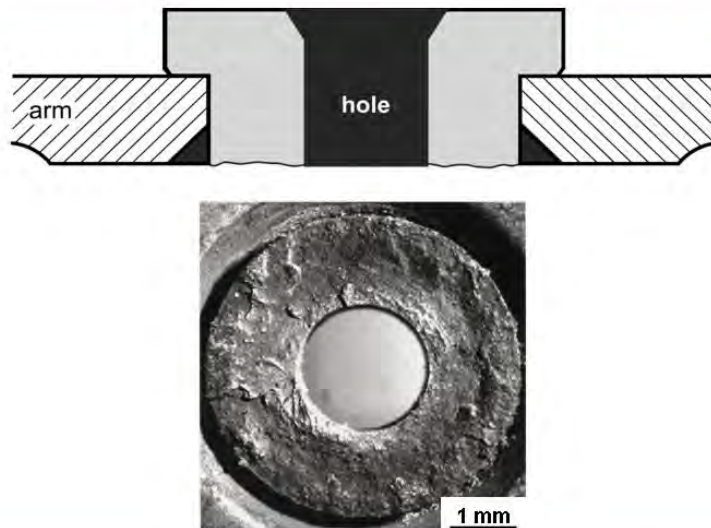

91

SEM fractographs of pin fracture surface

- Corrosion pits and slots starting from hole in pin head

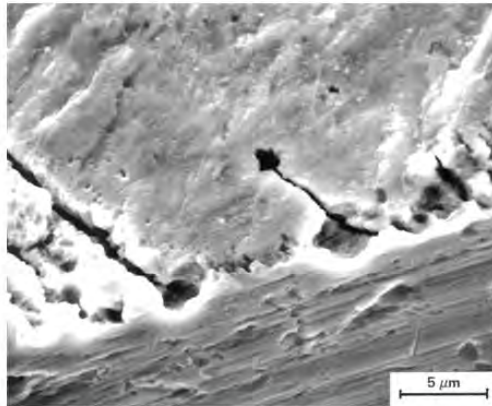

- Transgranular stress corrosion cracking (SCC)

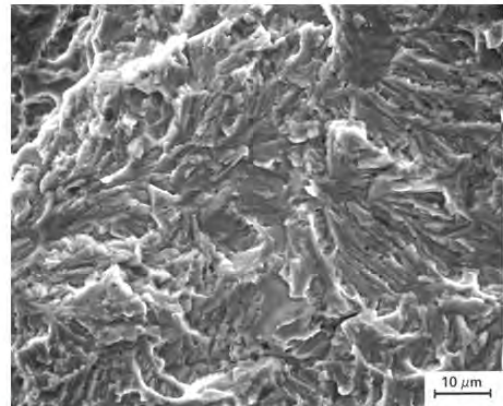

Causes of failure (I)

- Physical causes overview

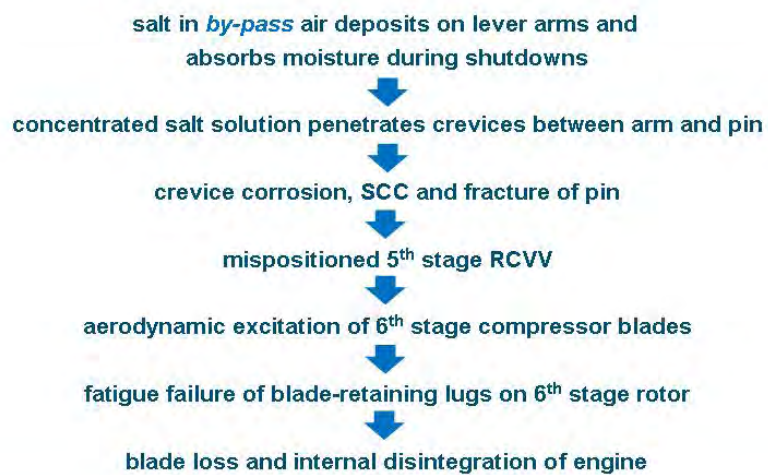

Causes of failure (II) and remedial actions

- **Primary causes**

- Nitronic 60 SCC susceptibility unknown to P&W before failure
- SCC in salt solution enabled by high residual stresses from cold-upsetting the pin head to attach it to the lever arm

- **Remedial actions**

- change pin material to Inconel 625 (immune to SCC in salt water)
- replace Inconel 718/Nitronic 60 assemblies by Inconel 718/Inconel 625:
 - change part number (PN)
 - frequent inspections of “old” assemblies until replacement complete
- scrap Inconel 718/Nitronic 60 assemblies

Westland Lynx SH14D helicopter rotor hub (1998)

95

Aircraft *type*: Westland Lynx SH14D



96

Lynx-282 airframe wreckage after rotor hub failure 



97

Lynx-282 rotor hub wreckage 



98

Schematic of rotor hub failure: Ti-6Al-4V ($\alpha + \beta$) processed titanium alloy forging

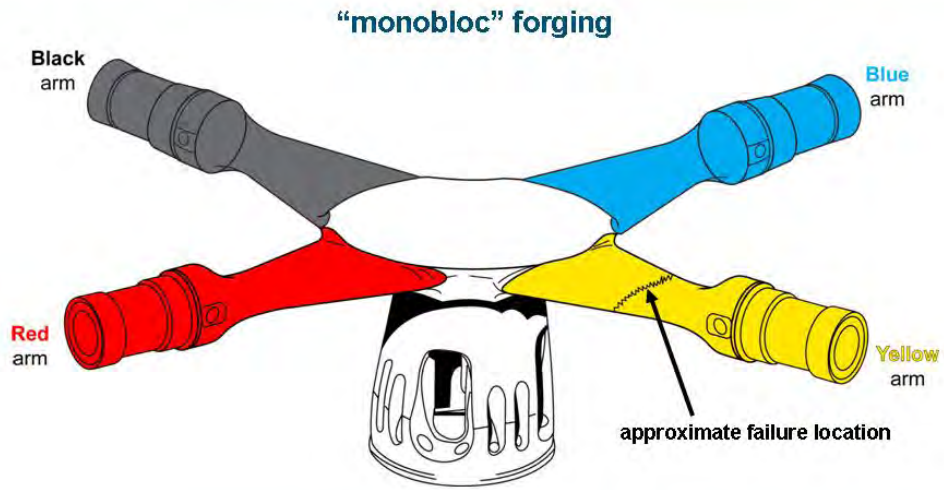

Outboard fracture surface of the "yellow" arm *in situ*





Outboard fracture surface with schematic of fatigue initiation area

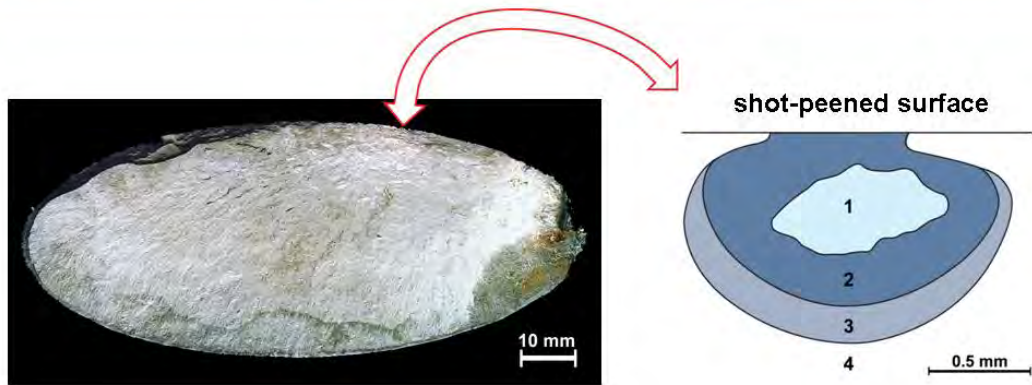

- phases of the yellow arm fatigue life:
 - 1 – highly faceted sub-surface fatigue initiation *in vacuo*
 - 2 – rough early crack growth *in vacuo*
 - 3 – rough early crack growth in air
 - 4 – less rough crack growth in air

Failure analysis topics and results

Hub manufacture		Results
Processing and heat-treatment	Metallurgical defects Microstructural factors influencing fatigue Chemical composition	No problems
Finishing	Stress relief anneal Final machining Shot peening Dimensions Residual stress measurements Scratches Scratches and secondary cracks	
Service		Results
Service damage	Scratches and secondary cracks	No problems
Service stress level estimates	Service failure <i>versus</i> full-scale test Service failure <i>versus</i> specimen tests	Too-high stresses

Service stress level estimates: summary

- **Fatigue stress estimates obtained from fractographic analyses and fracture mechanics concepts* applied to and comparing**
 - service and full-scale test failures
 - service and specimen test failures
- **Results suggested frequently occurring fatigue stresses higher than those used in design**
- **Estimates supported by *subsequent* service load measurements**

*R.J.H. Wanhill, in: *Practical Failure Analysis*, Vol. 3(2), 2003, pp. 59-69

103

Causes of failure and remedial actions

- **Physical cause: too-high dynamic stresses → fatigue**
- **Contributing cause: inadequate fatigue design analysis**
- **Remedial action: new design rotor hub**
 - non-“monobloc” bolted-on arms
 - Ti-10V-2Fe-3Al β titanium alloy replacing Ti-6Al-4V

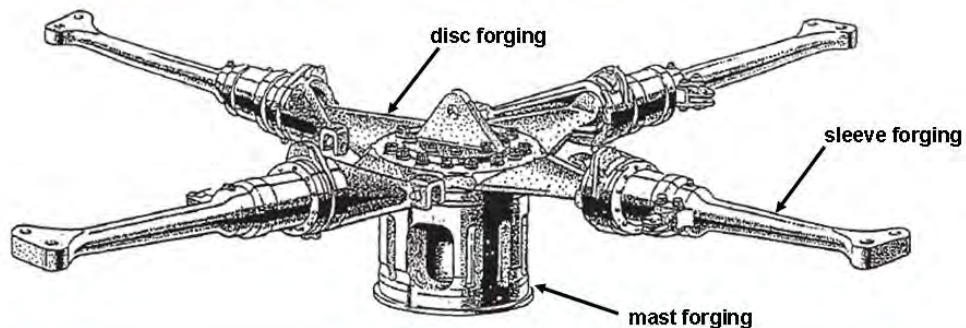

104