

MIXED-MODE S-PARAMETER MEASUREMENTS FOR DETERMINATION OF CABLE COUPLING

Jesper Lansink Rotgerink ⁽¹⁾⁽²⁾, Niek Moonen ⁽²⁾, Frank Leferink ⁽²⁾⁽³⁾

⁽¹⁾ *Netherlands Aerospace Centre, 8316 PR Marknesse, the Netherlands, e-mail: Jesper.Lansink.Rotgerink@nlr.nl*

⁽²⁾ *University of Twente, 7522 NB Enschede, the Netherlands*

⁽³⁾ *Thales Netherlands B.V., 7554 RR Hengelo, the Netherlands*

ABSTRACT

Single-ended S-parameters are used to quantify electro-magnetic coupling, or crosstalk, between cables. The use of this measurement technique is demonstrated on a case where crosstalk occurs between two wire pairs above ground. S-parameter measurements involve no elements that introduce frequency restrictions, such as baluns or current clamps. Moreover, by measuring or simulating all combinations of S-parameters and converting these to mixed-mode S-parameters, not only differential-mode (DM), but also common-mode (CM) and mode-conversion S-parameters are obtained. When only the coupling between a specific combination of cables is desired, it is sufficient to measure only a small subset of all S-parameters. Finally, the relation between crosstalk as defined in the standards and the obtained S-parameters is discussed.

1. INTRODUCTION

Risk-based development towards More Electric Aircraft (MEA) requires an early assessment of crosstalk in the multiple hundreds of kilometers of on-board cables. Due to the growing amount of cabling and the decreasing space that is available in such aircraft, crosstalk is an important topic in the optimization of an Electrical Wiring Interconnection System (EWIS).

Various measurement techniques can be applied to evaluate crosstalk levels between cabling. For instance, a spectrum analyzer can be used to measure the induced voltage at near-end or far-end side of a victim transmission line, while the culprit signal is provided by a (tracking) generator [1]. When measuring coupling between wire pairs in this way, baluns are necessary to connect the balanced wire pairs to the unbalanced measurement equipment. These baluns cause a frequency limitation in the measurement setup, in the case of [1] equal to roughly 100 kHz to 400 MHz. In [2] baluns were found unnecessary in a measurement set-up where current clamps were used to measure crosstalk currents in cable bundles. However, also here the current clamps introduce a frequency limitation into the measurement set-up, in this case 1 MHz to 100 MHz.

In our paper, we focus on the use of S-parameters

as quantification of electro-magnetic (EM) coupling between cables. By measuring single-ended S-parameters baluns can be omitted. These single-ended S-parameters can then be transformed to mixed-mode S-parameters [3] to obtain characteristics of for instance wire pairs. Since baluns are unnecessary, the risk of possible parasitic behavior of the baluns is lost, and there is no more frequency restriction caused by the baluns. The only element in such a measurement set-up yielding a frequency limitation is the vector network analyzer (VNA) that is used. Moreover, with the method described in this paper not only DM coupling is measured, but also CM coupling and the mode-conversion S-parameters are obtained. In [4] single-ended S-parameter measurements are applied in a multi-VNA configuration with 4 ports to measure worst-case crosstalk in in-situ cables. Here we demonstrate the conversion of single-ended S-parameter measurements to mixed-mode S-parameters in a crosstalk situation of two wire pairs above a ground plane, yielding 8 single-ended ports. If all 28 combinations of single-ended S-parameters are measured, then all DM, CM and mode-conversion S-parameters are obtained. However, if one is only interested in for instance near-end DM cable coupling, measurement of only 4 single-ended S-parameters suffices.

Section 2 of this paper describes the crosstalk test case and the conversions from single-ended to mixed-mode S-parameters, including some results from simulations. Section 3 describes the measurement set-up, while Section 4 shows the corresponding results. In Section 5 we discuss the use of S-parameters compared to the crosstalk definition and in Section 6 we give conclusions.

2. SINGLE-ENDED S-PARAMETERS FOR DETERMINATION OF CABLE COUPLING

Consider a case of two unshielded, untwisted wire pairs above a ground plane, as illustrated by the cross section in Fig. 1. The parameters shown are the height above the ground h , intra-pair separation distance a , the wire radius r and the inter-pair separation distance d . In practice these wire pairs are terminated by a certain DM and CM

impedance, Z_d and Z_c . If a voltage source is present in the termination network of one of the two wire pairs signals in the culprit pair will be coupled to the victim wire pair. In that case, crosstalk can be defined by:

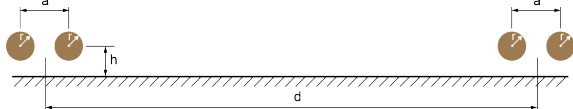

Figure 1. Cross section of two wire pairs above a ground plane.

$$\gamma_{NE/FE} = \frac{V_{v,NE/FE}}{V_c}. \quad (1)$$

Here V_c is the voltage between the wires of the culprit pair, close to the source. The voltage that is induced in the victim pair at the near or far-end side of the cable is given by $V_{v,NE}$ or $V_{v,FE}$, respectively, which depends on all per-unit-length (PUL) parameters as well as termination impedances. The definition in (1) is consistent with for instance standard [6]. In this paper we show only results for near-end crosstalk (NEXT). Similar observations can be made for the far-end case.

The test case given in Fig. 1 has also been analyzed in [1], however in this paper slightly different parameter values will be used. In [1] crosstalk between the two wire pairs was measured by using baluns to connect the balanced wire pairs to the unbalanced coaxial cables running to the measurement equipment. In this set-up there is a known DM impedance between the wire pairs, as well as a known common-mode impedance to ground. A generator with preamplifier was used to insert the source signal into the culprit transmission line, while a spectrum analyzer was used to analyze the near-end voltage. The test case has also been simulated by using multi-conductor transmission line theory. In both measurement and simulation, near-end crosstalk was computed following Eq. 1.

In contrast to this method, a VNA can also be used to measure cable coupling without the use of baluns. Therefore, single-ended S-parameters are measured by connecting the VNA to each single-ended port. The port definitions are illustrated in Fig. 2. For single-ended S-parameter measurements one port is defined between each wire-end of the wire pairs and ground, yielding 8 single-ended ports. Measurements of all combinations of these 8 ports fill up an 8x8 matrix of single-ended S-parameters. These can be converted to the mixed-mode S-parameters for the 4-port network in Fig. 2a) by:

$$\mathbf{S}_{mm} = \mathbf{M}\mathbf{S}_s\mathbf{M}^{-1}, \quad (2)$$

in which \mathbf{S}_s is the matrix of all single-ended S-

parameters and \mathbf{S}_{mm} is the matrix with mixed-mode S-parameters given by:

$$\mathbf{S}_{mm} = \begin{bmatrix} \mathbf{S}_{dd} & \mathbf{S}_{dc} \\ \mathbf{S}_{cd} & \mathbf{S}_{cc} \end{bmatrix}, \quad \mathbf{S}_{dd} = \begin{bmatrix} S_{dd11} & \cdots & S_{dd14} \\ \vdots & \ddots & \vdots \\ S_{dd41} & \cdots & S_{dd44} \end{bmatrix} \dots \quad (3)$$

The matrices \mathbf{S}_{dc} , \mathbf{S}_{cd} and \mathbf{S}_{cc} are also defined in the same way as \mathbf{S}_{dd} . Finally, in the above, \mathbf{M} is the conversion matrix, which is in this case given by:

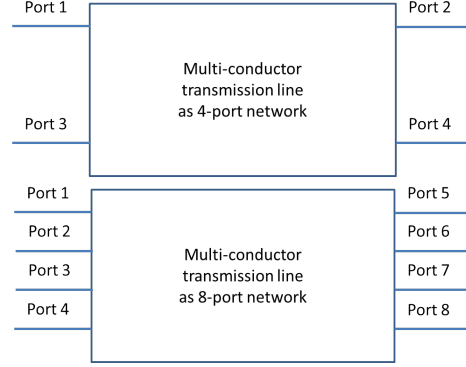

Figure 2. Port definitions for a) (top) the four ports of the mixed-mode case and b) (bottom) the eight ports of the single-ended case.

$$\mathbf{M} = \begin{bmatrix} \mathbf{M}_4 & \mathbf{0} \\ \mathbf{0} & \mathbf{M}_4 \end{bmatrix}, \quad \mathbf{M}_4 = \begin{bmatrix} 1 & -1 & 0 & 0 \\ 1 & 1 & 0 & 0 \\ 0 & 0 & 1 & -1 \\ 0 & 0 & 1 & 1 \end{bmatrix} \quad (4)$$

In this case for the mixed-mode S-parameters ports 1 and 2 are the near-end and far-end side of the culprit pair, while the victim pair exhibits ports 3 and 4. Thus, for near-end DM cable coupling we are interested in S_{dd13} .

Simulation software packages like FEKO or CST have the ability to calculate all combinations of single-ended S-parameters at once. The case of two wire pairs above ground is created in simulation and the terminations of this model are shown in Fig. 3b), in which the ports have an impedance of 50 Ω . For the four-port configuration the simulation model is created like shown in Fig. 3a) with port impedances equal to 100 Ω . Fig. 4 shows the simulated results of the S_{13} in the four-port network (red dashed curve) and S_{dd13} that is computed from the simulated single-ended S-parameters for the eight-port network (blue curve). This was done with the simulation parameters set to: $h = 2.9$ mm, $a = 3.4$ mm, $r = 0.2$ mm and $d = 10$ mm. The length of the annealed copper wires was equal to 175.6 cm, and the ground plane was a 185 x 2.36 cm aluminum plate (these dimensions resemble the measurement setup in the next section). The results show that the two set-ups indeed yield equal results.

Therefore, single-ended S-parameter measurements can be used to determine the mixed-mode S-parameters. Only at the extremities of our frequency plots there are some minor differences. These might be caused by the losses in the wires and the aluminum ground plane that could have slightly different effects in the 4-port and the 8-port case. A final observation about these simulation results is that the increasing crosstalk for high frequencies is caused by the use of the small ground plane. For large ground planes (or infinite in simulations) crosstalk levels reach

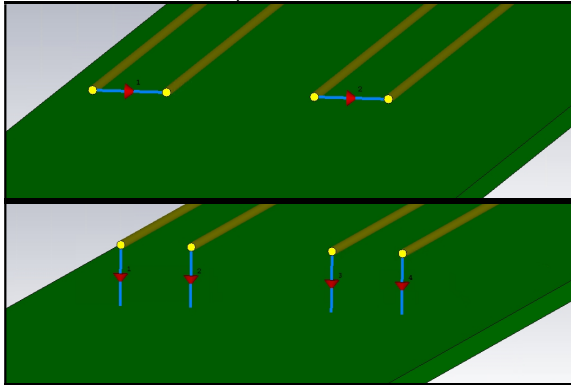

Figure 3. Simulation models of a) (top) DM setup and b) (bottom) single-ended setup for S-parameter simulations

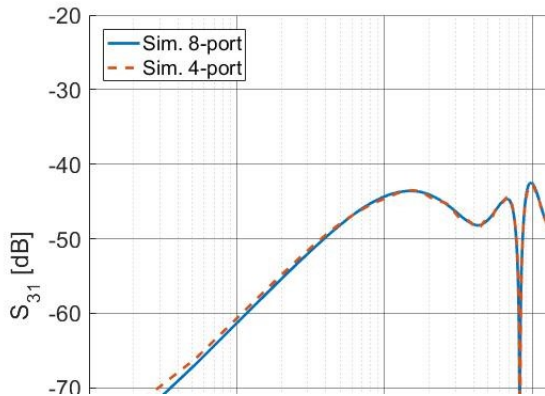

Figure 4. Results of simulated S-parameters. The red dashed trace shows S_{13} for the case of differential setup (Fig. 3a) and the blue trace shows the computed DM S_{dd13} parameter by converting single-ended S-parameters (Fig. 3b) into mixed-mode S-parameters.

a plateau [1].

3. MEASUREMENT SETUP

The measurement setup as shown in Fig. 5 consists of 4 wires of approximately 163 cm length. Each wire is individually connected to a soldered screw connector as can be seen in Fig. 5. Isolated wires are running to the SMA connector, at which the measurement equipment was calibrated. Wire spacers are placed at approximately 10 cm

intervals over the entire length of the wires. This ensures the height to the ground plane being 3 mm (h), intra-pair separation of 3 mm (a) and inter-pair separation of 10 mm (d). For the finishing of the wires these parameters are obviously not maintained and discrepancies exist. This is assumed to have a relatively low influence as it accounts for approximately less than 5% of the transmission line on both sides.

The E5061B VNA of Keysight is used to perform the measurements from 100 kHz up until 3 GHz. The output power of the VNA was set to 10 dBm, and the results

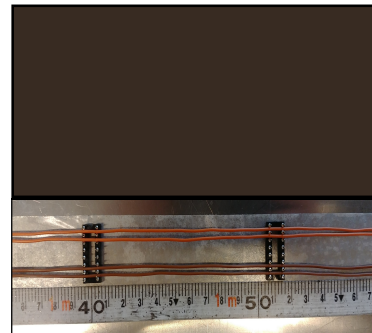

Figure 5. Measurement setup with 4 wires, representing two differential pairs connected in total to 8 SMA connectors of which 6 are terminated with 50Ω loads and 2 connected to the VNA.

are averaged over 10 sweeps.

Direct DM and CM S-parameter measurements have also been performed, to make a similar comparison with measurements like the one in Fig. 4. Such measurements have been performed using adapters for CM and DM NEXT as shown in Fig. 5. These results will be compared to the conversion of measured single-ended S-parameter. CM measurements have been added to demonstrate the applicability of the proposed methodology, as these adapters have fewer restrictions in for instance frequency. The DM measurements are shown to emphasize the benefit of single-ended measurements, as the balancing can be challenging to maintain over a wide frequency band. Fig. 7 shows the measurement results of the unbalance/imbalance between ports 1 and 2 for the DM adapter. Comparing the results outside the valid range with the results inside, shows that the phase unbalance is manageable, however the amplitude unbalance is relatively high. In case of the CM adapters, the unbalance in amplitude is less than 0.05dB and in phase less than 4° over the entire measurement region.

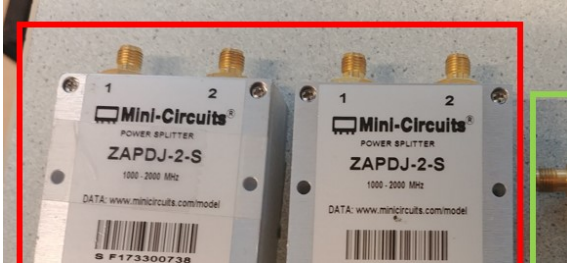

Figure 6. Adapters to perform CM and DM measurements. The ZAPDJ-2-S are valid (according to the datasheets) from 1 GHz to 2 GHz as they are providing a 180° phase shift between ports 1 and 2. While the ZFRSC-123-S+ are valid from DC to 12 GHz, as they basically consist of two resistive dividers.

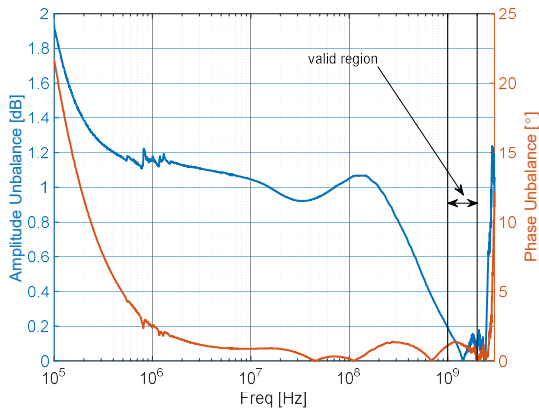

Figure 7. Amplitude and Phase unbalance between ports 1 and 2 of ZAPDJ-2-S adapter (DM).

4. Results

The presented results are limited to NEXT for readability even though the measurement results, amongst other, also contain FEXT. In Fig. 8 the resulting S_{dd31} from a CST simulation is shown with the S_{dd31} from our measurements. The simulation parameters are as given in section 2. Crosstalk levels seem comparable in the lower frequency area ($f < 10$ MHz), however large deviations are visible above this frequency. The observed differences between measurement and simulation are expectedly caused by differences in the model and actual setup, among which are uncertainties in the measurement setup, both along the length of the wire pairs, as well as in the finishing to the connectors. Moreover, the behavior of connectors has not been modelled.

Figures 9 and 10 show the measurement results obtained by converting the measured single-ended S-parameters (blue curve) and by using the DM adapter discussed in section 3. Fig. 9 shows large deviations especially for frequencies below 10 MHz, however these can be attributed to the limited frequency range for which the adapter is

valid. Fig. 10 shows the results in the valid region, and we can see that both methods show similar results, which supports the applicability of the measurement method.

Finally, in Fig. 11 similar measurement results for CM NEXT are presented from 100 kHz to 1 GHz. In this case, since the CM adapters can be used along the entire frequency range, the directly measured CM S-parameters and the converted single-ended S-parameters match very well. As in the simulations, only for the extremities in our frequency range there are minor differences.

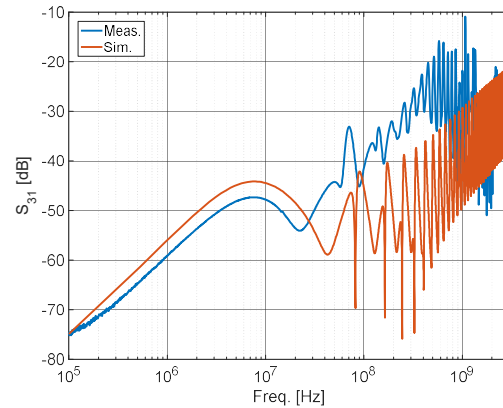

Figure 8. Results of simulated and measured S-parameter attributed to DM NEXT. Both show the calculated S_{dd13} parameter by converting from single-ended S-parameter results.

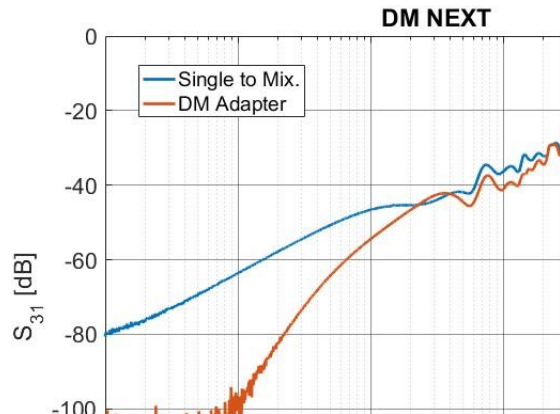

Figure 9. Results of measured S-parameter attributed to DM NEXT. The calculated S_{dd13} parameter is given in blue, while orange shows directly measured with DM adapters.

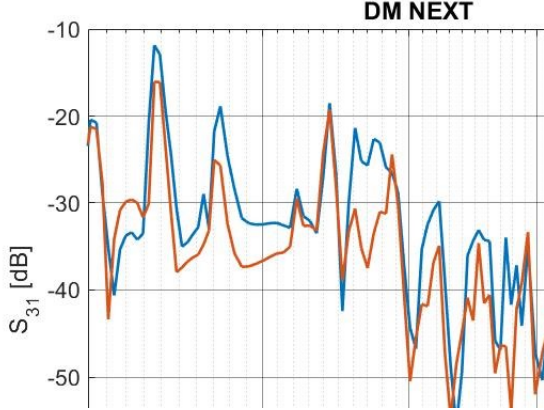

Figure 10. Results of measured S-parameter attributed to DM NEXT. The calculated S_{dd13} parameter is given in blue, while orange shows directly measured with DM adapters. Compared to Fig. 9, the frequency range has been adapted to the region in which the adapter has been deemed valid.

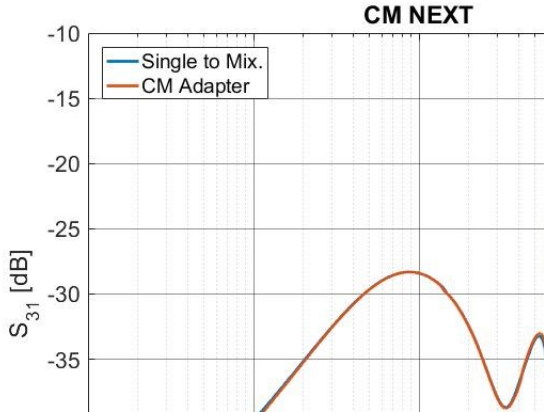

Figure 11. Results of measured S-parameter attributed to CM NEXT. The calculated S_{cc13} parameter is given in blue, while orange shows directly measured with CM adapters.

5. DISCUSSION

Computation of the DM S-parameters from simulated or measured single-ended S-parameters, as performed in the previous sections, yields a good quantity for the amount of crosstalk between two cables. However, in general the S_{dd13} parameter is not completely equivalent to the near-end crosstalk value as defined in the standard [6] and Eq. 1. By definition the S-parameters relate incident and reflected power waves:

$$\mathbf{b} = \mathbf{S}\mathbf{a}. \quad (5)$$

Here the matrix \mathbf{S} contains elements S_{ji} , being the S-parameters between ports i and j . The vectors \mathbf{a} and \mathbf{b} contain as elements the incident and reflected power waves at each port, respectively. These are defined as [5]:

$$\begin{aligned} a_i &= \frac{1}{2}k_i(V_i + Z_i I_i) \\ b_i &= \frac{1}{2}k_i(V_i - Z_i^* I_i) \\ k_i &= \left(\sqrt{|\mathcal{R}(Z_i)|}\right)^{-1}. \end{aligned} \quad (6)$$

Here V_i and I_i are the voltage and current at port i and Z_i and Z_i^* are the impedance for port i and its complex conjugate. Under the assumption that port 1 is terminated with the characteristic impedance, the simplified representation of the S-parameter that characterizes the near-end cable coupling is:

$$S_{13} = \frac{b_1}{a_3}. \quad (7)$$

This illustrates that on the one hand these S-parameters are a ratio of power waves, while on the other hand the definition of crosstalk is given in Eq. 1 and equals the ratio of voltages over the terminations of the transmission line. In Fig. 12 a comparison is made between simulation results of crosstalk following the definition and simulated S_{dd13} . Clearly, the results are equal for lines that are short in terms of wavelength, but

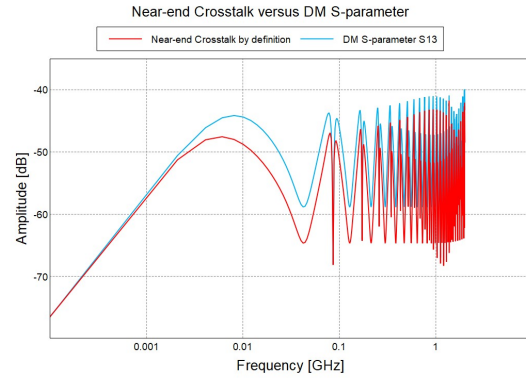

Figure 12. Results of MTL simulations for near-end crosstalk and S_{dd13} .

differ slightly in the resonance area. Thus S-parameter measurements yield a good measure for the amount of EM coupling between cables, but are not equivalent to the crosstalk definition in the high-frequency area.

6. CONCLUSIONS

Single-ended S-parameters that are obtained from measurements or simulations can be converted to mixed-mode S-parameters to obtain measurement results that are similar to near-end crosstalk measurements. This is demonstrated in this paper with a crosstalk case of two wire pairs above a perfectly conducting aluminum ground plane. In simulation the conversion of single-ended S-parameters to DM crosstalk yields results that are equal to the actual DM

S-parameters.

The measurements have shown consistency between single-ended to mixed mode parameters and direct DM/CM S-parameters. Parasitic behavior introduced either by the adapter and/or termination impedance mismatching needs to be investigated more thoroughly to determine the exact implications of the mismatches in results. However, based on theory and simulation, the measurement results have shown promising possibilities to characterize and analyze multiple I/O systems, even using analyzers with a limited number of ports over a wide frequency range.

7. REFERENCES

- [1] Lansink Rotgerink, J., Schippers H. & Leferink, F. (2018), Low-frequency analysis of Multiconductor Transmission Lines for Crosstalk Design Rules, *IEEE Transactions on Electromagnetic Compatibility*, Early Access.
- [2]. Jullien, C., Besnier, P., Dunand, M. & Junqua, I., Crosstalk analysis in complex aeronautical bundle, *Proc. International Symposium on EMC (EMC Europe)*, Brugge, Belgium, September 2-6, 2013, pp. 253-258.
- [3]. Bockelman, D.E. & Eisenstadt, W.R., Pure-mode network analyzer for on-wafer measurements of mixed-mode S-parameters of differential circuits, *IEEE Transactions on Microwave Theory and Techniques*, Vol. 45, No. 7, July 1997, pp. 1071-1077.
- [4]. Collins, J.C. & Bray, J.R., Worst-case crosstalk measurements of cables – The multinet network analyzer method, *IEEE Transactions on Electromagnetic Compatibility*, Vol. 60, No. 4, August 2018, pp. 1061-1068.
- [5]. Kurokawa, K., Power waves and the scattering matrix, *IEEE Transactions on Microwave Theory and Techniques*, Vol. 13, No. 2, March 1965, pp. 194-202.
- [6]. IEC 61935-1: 2009 E, Specification of the testing of balanced and coaxial information technology cabling – part 1: installed balanced cabling as specified in ISO/IEC 11801 and related standards, Geneva, Switzerland, July 2009.