



Executive summary

Development of a thermoplastic aircraft composite linkage part



Description of work

Based on a manufacturing trade-off study and stress calculations a butt-joint thermoplastic concept was chosen for the manufacturing of the NICETRIP combiners. The concept exists of the manufacturing of flat sheets for the preforms. The preforms are milled from this sheet and after that placed in a steel mold for consolidation into a three-dimensional shape. Since the combiner is mainly loaded in the direction of the flanges, no continuous fibers between the shear webs and the flanges are required and therefore a butt-jointed concept could be used. After consolidation, only the edges of the flanges have to be trimmed and the holes have to be milled. The final step is the installation of the bushings.

Report no.

NLR-TP-2013-141

Author(s)

P. Nijhuis

Report classification

UNCLASSIFIED

Date

March 2013

Knowledge area(s)

Constructie- en
fabricagetechnologie

Descriptor(s)

Combiner
Butt joint
PEKK
NICETRIP

Problem area

In the frame work of a European program, NICETRIP (Novel Innovative Competitive Effective Tilt Rotor Integrated Project), design studies are accomplished for a tilt rotor aircraft. To reduce the weight of the rotor hub, composite replacements of metal rotor hub parts are investigated. In this paper the re-design and manufacture of a specific part, the combiners, will be described

Results and conclusions

The selected manufacturing concept worked very well with the potential of cost reduction, and showed the feasibility of developing a critical part using advanced thermoplastic composite resulting in weight reduction.

Applicability

Components mainly loaded in inplane directions and without large transverse loads.

This report is presented on Sampe 2013 Long Beach (CA).



NLR-TP-2013-141

Development of a thermoplastic aircraft composite linkage part



P. Nijhuis

This report is presented on Sampe 2013 Long Beach (CA).

The contents of this report may be cited on condition that full credit is given to NLR and the authors.

Customer National Aerospace Laboratory NLR
Contract number 2046205.6 (ST1036)
Owner National Aerospace Laboratory NLR
Division NLR Aerospace Vehicles
Distribution Unlimited
Classification of title Unclassified
March 2013

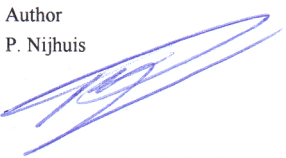
Approved by:

Author P. Nijhuis 	Reviewer H.P.J. de Vries 	Managing department H.G.S.J. Thuis 
Date: 21/3/2013	Date: 3-4-2013	Date: 5-4-2013

Summary

In the frame work of a European program, NICETRIP (Novel Innovative Competitive Effective Tilt Rotor Integrated Project), design studies are accomplished for a tilt rotor aircraft. To reduce the weight of the rotor hub, composite replacements of metal rotor hub parts are investigated. In this paper the re-design and manufacture of a specific part, the combiners, will be described.

Based on a manufacturing trade-off study and stress calculations a butt-joint thermoplastic concept was chosen for the manufacturing of the NICETRIP combiners. The concept exists of the manufacturing of flat sheets for the preforms. The preforms are milled from this sheet and after that placed in a steel mold for consolidation into a three-dimensional shape. Since the combiner is mainly loaded in the direction of the flanges, no continuous fibers between the shear webs and the flanges are required and therefore a butt-jointed concept could be used.

After consolidation, only the edges of the flanges have to be trimmed and the holes have to be milled. The final step is the installation of the bushings. See figure 1 for the final result. The selected manufacturing concept worked very well with the potential of cost reduction, and showed the feasibility of developing a critical part using advanced thermoplastic composite resulting in weight reduction.



Figure 1. Final composite combiner

Contents

1	Introduction	4
2	Experimentation	5
2.1	Conceptual design	5
2.2	Design	6
2.3	Manufacturing	9
2.4	Verification	10
3	Results	11
4	Conclusions	12
5	Acknowledgement	12

1 Introduction

To reduce the weight of the rotor hub of a tilt rotor aircraft within the NICETRIP program, composite replacements of the rotor hub parts were investigated. This report describes the investigation done on the so called combiners. The combiners are located on the rotating part of the rotor head and create a link between the flight control movements of the pilot and the blade rotation, see figure 2.

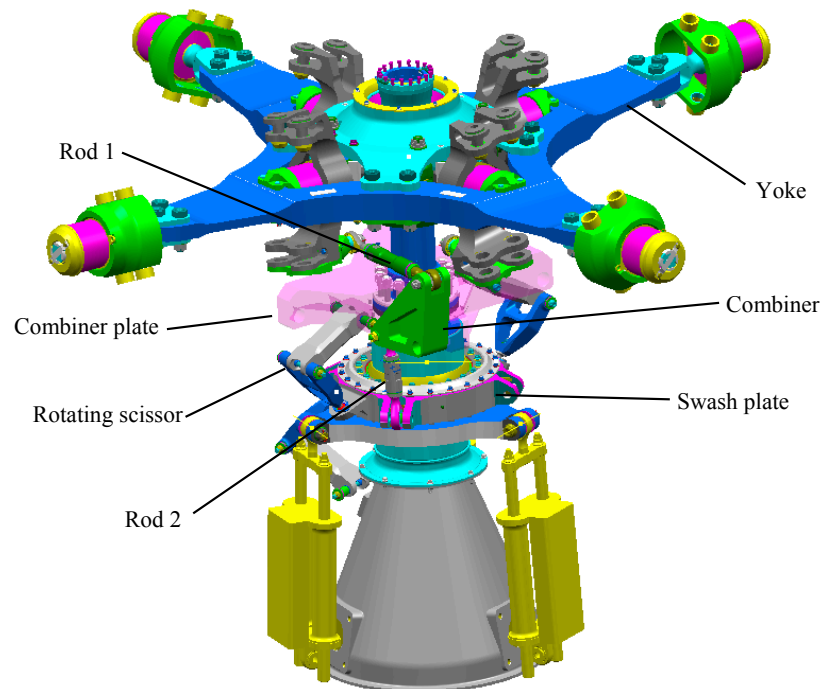

Figure 2. Rotor hub with combiner

The original combiner was made of steel and weighed 3.9 kg. The combiner is loaded by the two rods and by the centrifugal forces. This paper describes briefly the work done to investigate the possibilities of using composite materials for the combiners. The paper describes the design and manufacturing of a prototype.

2 Experimentation

2.1 Conceptual design

For a combiner made of composite materials four different concepts have been considered:

- Concept 1: plies folded into shear webs
- Concept 2: single flat plate
- Concept 3: double flat plate
- Concept 4: thermoplastic with welded/co-consolidated shear webs

Concepts 1 and 4 were identified as the more preferable ones. Figure 3 shows both design concepts.

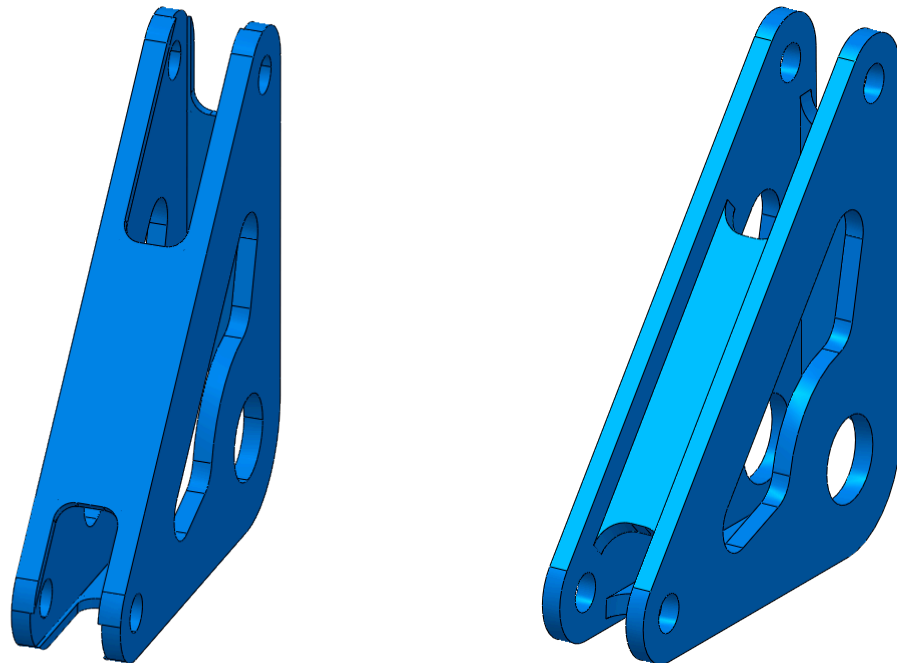

(a) Concept 1 with plies folded into the webs (b) Concept 4 with co-consolidated webs

Figure 3. Two conceptual designs for the combiner

Concept 1, which is to be manufactured by means of RTM (resin transfer molding), is the best design to handle bending moments and shear forces. By folding the plies into the shear webs, the shear forces are introduced into these webs by continuous $\pm 45^\circ$ fibers. However, a complicated preform has to be produced and five sides have to be milled to create the end product.

Preliminary finite element analyses showed that the load transfer between shear webs and the triangular plates is low. Therefore, the possibility for a thermoplastic design with welded/co-

consolidated butt-joined shear webs was investigated. Such a component can be manufactured as a large flat plate out of which multiple combiners and separate shear webs can be milled. Next, only an assembly mold is needed to co-consolidate the parts. This results in a very cheap product. Further, thermoplastic materials such as PEKK or PEEK have better interlaminar shear, bearing, compression after impact and open hole compression/tension properties than epoxy resins suitable for RTM. However, in this design concept the shear forces are introduced into the webs via a matrix interface, which is known to be sensitive to fatigue.

As concept 4 offers the opportunity for a huge cost reduction, the thermoplastic design with co-consolidated shear webs has been selected for further detailing and evaluation.

2.2 Design

The loads on the combiner are a function of the blade moment and angle. They also depend on the rotational speed. With a constant speed of 581 rpm, the centrifugal loads are constant. The definition of the load positions and dimensions are given in figure 4. The total forces and bending moments are calculated for several blade angles and moments. To give an idea of the loads, the maximum loads and moments at the maximum positive blade moment of 3232 Nm are given in table 1. The load position definition is given in figure 4.

Table 1. Maximum loads and moments

$F_{x,1} = 19,640 \text{ N}$	$F_{x,2} = 2,383 \text{ N}$
$F_{y,1} = -1,066 \text{ N}$	$F_{y,2} = -833 \text{ N}$
$F_{z,1} = -306 \text{ N}$	$F_{z,2} = -20,808 \text{ N}$
$F_{x,3} = -23,108 \text{ N}$	$M_{x,3} = -213 \text{ Nm}$
$F_{y,3} = 2,659 \text{ N}$	$M_{y,3} = 0$
$F_{z,3} = 21,114 \text{ N}$	$M_{z,3} = -148 \text{ Nm}$

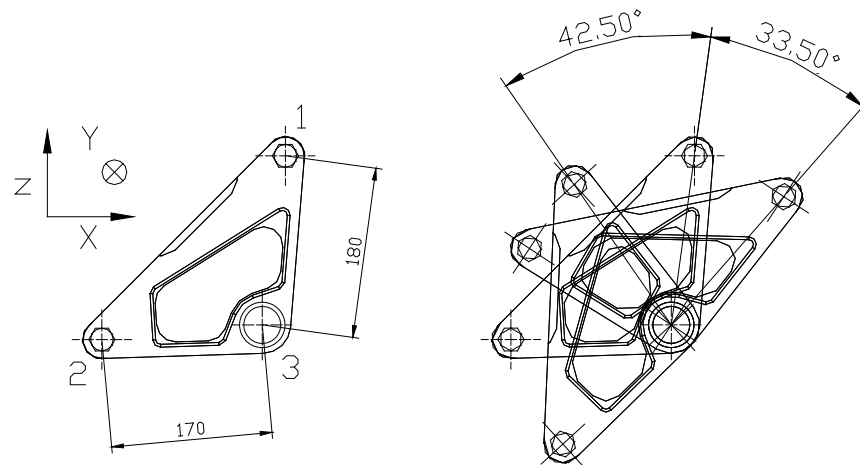

Figure 4. Load position definition and dimensions of the combiner

The FEM (finite element method) analyses were based on high crystalline PEKK-DS material with AS4D carbon fibers from Cytec. The design is based on Hot-Wet properties and analyses for static and dynamic loads were done. To accommodate for different load cases and load directions (in case the combiner is in any of the rotated positions of figure 4), a quasi-isotropic lay-up is applied in the plate. Since the plate and web are made from the same base plate, the thickness of the plate and the shear webs in the combiner is 10 mm. The shape of the cut-out in the triangular plate (see figure 3) is based on preliminary finite element analyses indicating very low strain levels in that particular area. Some typical deformations and strains are given in figures 5 and 6.

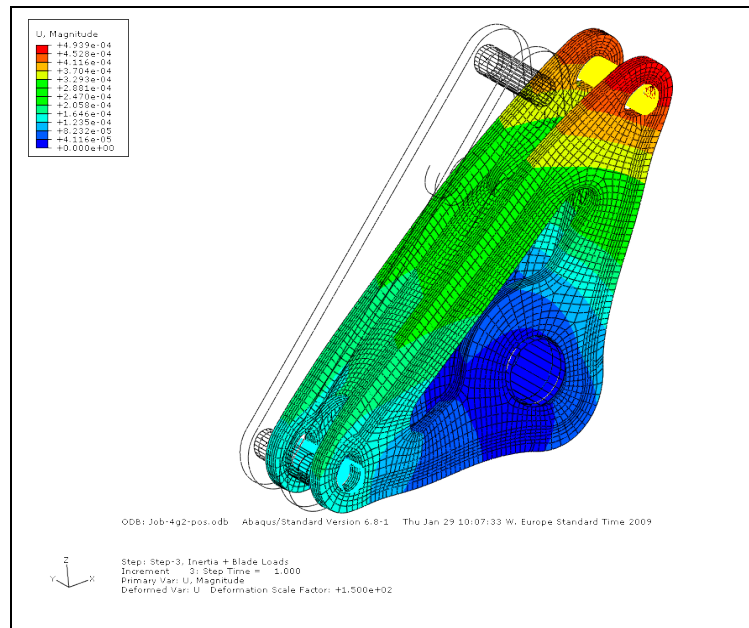
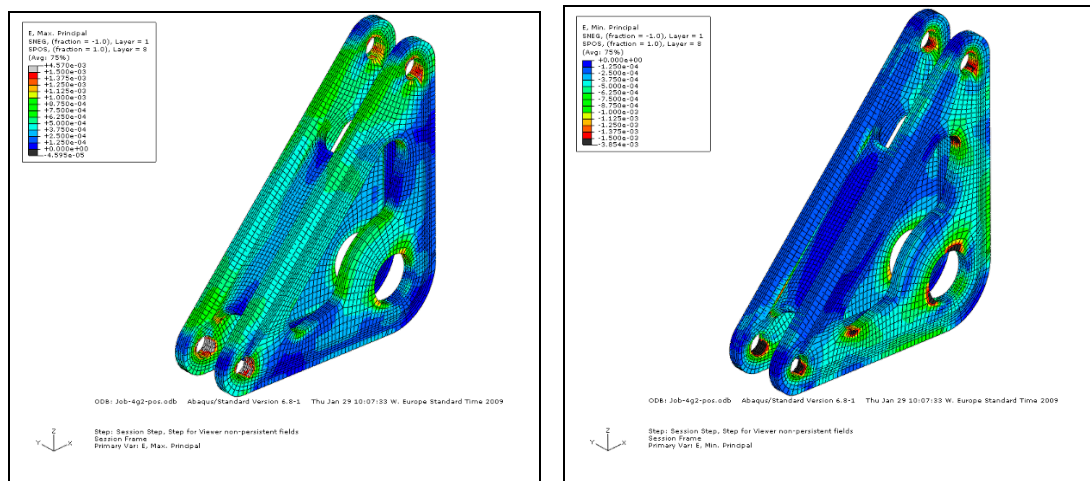

Figure 5. Deformations of the combiner due to blade loads together with centrifugal forces (positive blade moment of 3232 Nm and a rotational speed of 581 rpm)



(a) Max. principle strain

(b) Min. principle strain

Figure 6. Principle strains at limit load with combiner in nominal position

The resulting weight of the composite combiner is equal to 1.93 kg, including the metallic bushes. Compared to the current steel design for the combiner that weighs 3.9 kg, the composite design offers a 50% weight reduction.

2.3 Manufacturing

The combiners are made of PEKK-DS thermoplastic material produced by Cytec, with AS4D carbon fibers. Since the combiners are mainly loaded in the direction of the end plates, the connection of the shear webs with the end plates can be made without continuous fibers, i.e. as a butt-joint. The combination of thermoplastic material and the butt-joints makes it a very affordable process. First simple flat sheets were made with a $[0^\circ, 45^\circ, 90^\circ, -45^\circ]$, $[0^\circ, 90^\circ]$ $[-45^\circ, 90^\circ, 45^\circ, 0^\circ]$, quasi-isotropic lay-up. In this case an autoclave was used, but since the panels are flat, the panels can also be made in a hot press. The thickness of the panel was slightly more than 10 mm.

From the flat sheets, preforms were cut with a normal milling machine. Unfortunately, this was a time consuming process. Faster results with equal quality were obtained with waterjet cutting in other programs.

A mold concept was developed to consolidate the preforms into a combiner. See figure 7 for an overview. The pressure on the upper mold is transferred to the inner blocks. By using an angle on the outside of the inner blocks, pressure is transferred to the webs of the combiner.

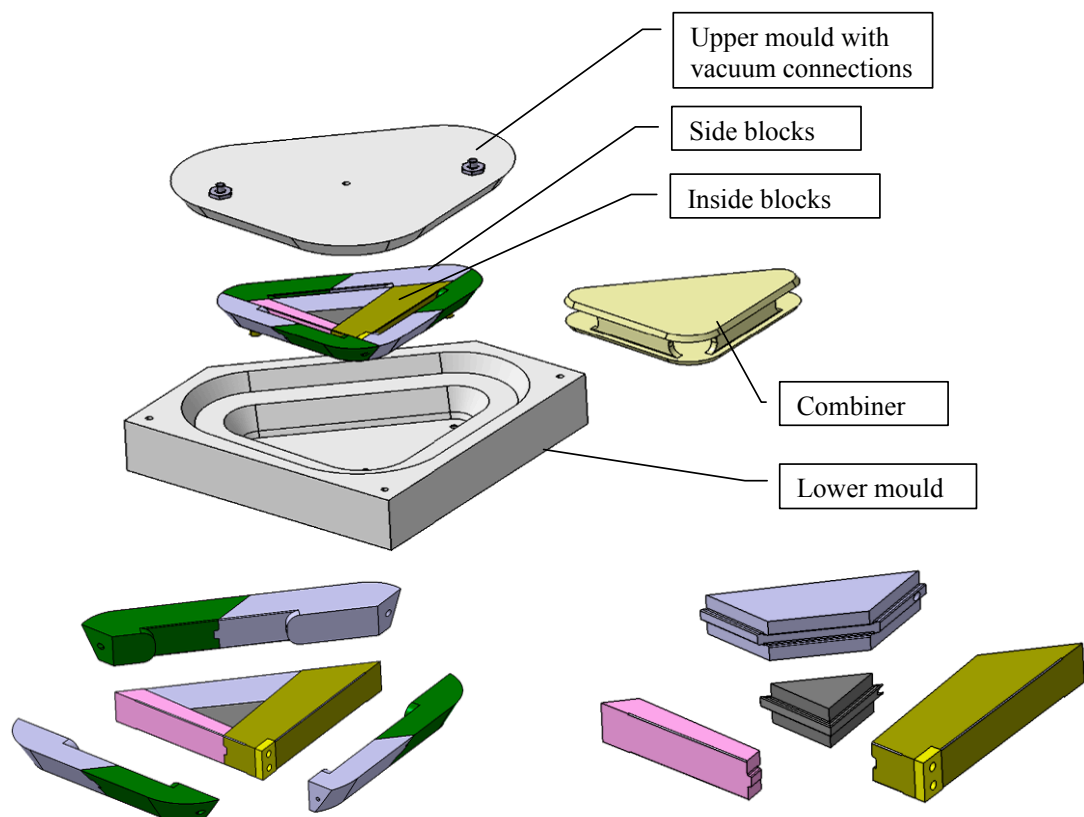

Figure 7. Mold concept with details of the inner blocks

The preforms were placed in the lower mold with the inner tooling blocks as shown in figure 8 to create the three-dimensional product with butt-joints. An easy vacuum bag was placed on top of the mold and the combiner was consolidated in the autoclave at 360 °C. To verify if the product could be made without an autoclave, one product was made using a hot press which gave similar results.

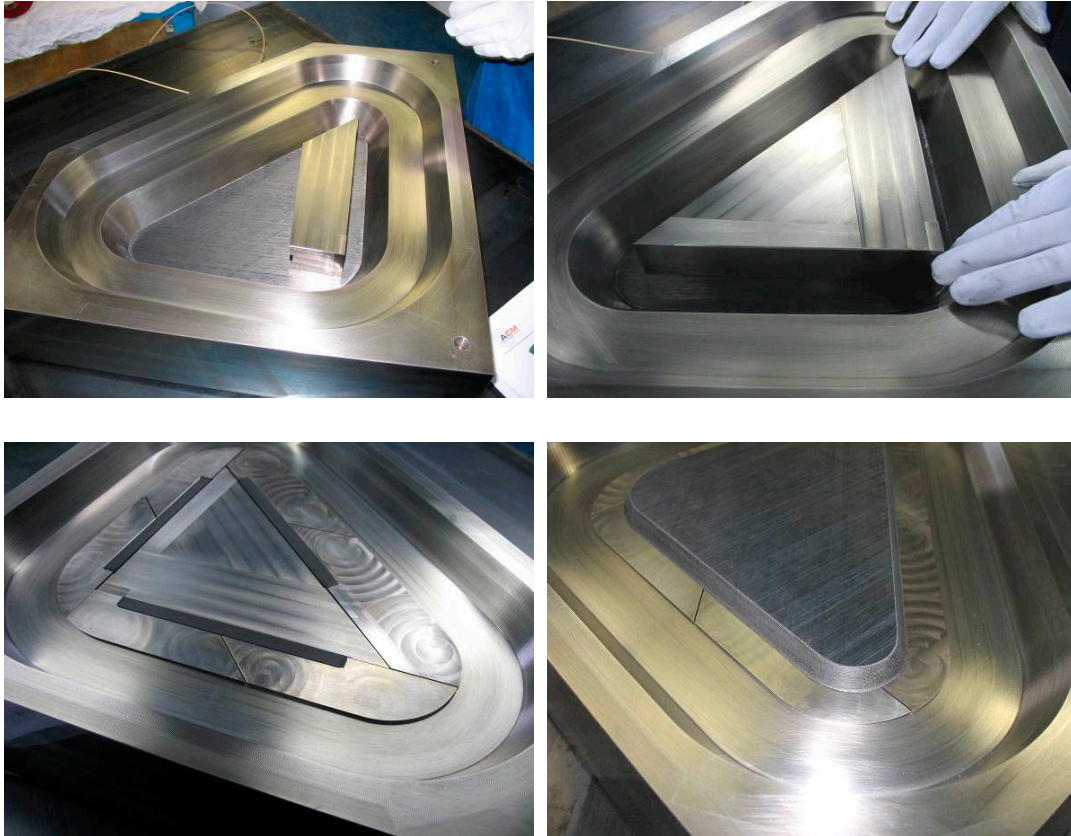

Figure 8. Filling the mold for a combiner (upper mold not shown)

After consolidation, only the edges were trimmed, holes were made and the bushings could be installed with a shrink fit. By using the current concept, only a simple 3-axis milling machine is required for the combiner.

2.4 Verification

The best way to verify a design is to test the complete product in a realistic situation. For the combiner a whirl tower test was planned to test the complete rotor. Unfortunately, the test was cancelled. For the PEKK/AS4D material, most mechanical properties were tested in other programs. Missing information were the dynamic bearing properties and shear properties of the butt-joint. Therefore bearing specimens and butt-joint thick adherend interlaminar shear specimens were tested. The thick adherend specimen lay-out is given in figure 9.



Figure 9. Thick adherend interlaminar shear test specimen with fiber layer direction (left)

The fatigue properties were as expected. The bearing strength in fatigue was about 67 % of the static strength. The fatigue shear strength is a matrix dominated property and drops to 30 % of the static strength. The derived bearing fatigue strength values are much higher than the maximum bearing stresses of 35 MPa in the component, as calculated in the strength analyses. The derived shear fatigue strength values of the tests are also significant higher than the maximum shear stresses of 5.19 MPa in the component.

3 Results

After the consolidation of the first combiners, some small issues had to be solved. Large white spots were found on the surfaces of the first combiner. Even some matrix material on the surface was missing at some points. This is a known problem during press forming, most probably caused by shrinkage of the mold. This was solved by adding a Kapton foil with a release agent (Frekote) between the mold and the product. Also, some small guiding pins were added to position the upper mold, so the upper flange position was within the desired tolerances. Some of the manufactured combiners are given in figure 10. The combiners were inspected with ultrasonic C-scan equipment, showing a good laminate and butt-joint quality.



Figure 10. Consolidated, milled and final products

4 Conclusions

The selected manufacturing concept of the combiners worked rather well. The preforms can be made in large series from cheap flat panels. After that, the preforms can be easily placed in an autoclave or press mold and consolidated. Only minor milling is required after consolidation on a two axial milling machine to trim the combiner to final shape. With this low cost production method and significant weight saving, a successful combiner concept was developed.

5 Acknowledgement

The investigations within this program were made possible by the European Commission. The NICETRIP partners wish to acknowledge the European Commission for the financial support of this project within the 6th Research Framework Program of the European Union. I also want to acknowledge Ralf Creemers (NLR) who did all the FEM analyses which are briefly described within this paper.