



Dedicated to innovation in aerospace

PUBLIC VERSION

NLR-CR-2017-160 | May 2017

RNAV Approach - Short Intercept

CUSTOMER: Air Traffic Control The Netherlands



NLR – Netherlands Aerospace Centre

Netherlands Aerospace Centre

NLR is a leading international research centre for aerospace. Bolstered by its multidisciplinary expertise and unrivalled research facilities, NLR provides innovative and integral solutions for the complex challenges in the aerospace sector.

NLR's activities span the full spectrum of Research Development Test & Evaluation (RDT & E). Given NLR's specialist knowledge and facilities, companies turn to NLR for validation, verification, qualification, simulation and evaluation. NLR thereby bridges the gap between research and practical applications, while working for both government and industry at home and abroad.

NLR stands for practical and innovative solutions, technical expertise and a long-term design vision. This allows NLR's cutting edge technology to find its way into successful aerospace programs of OEMs, including Airbus, Embraer and Pilatus. NLR contributes to (military) programs, such as ESA's IXV re-entry vehicle, the F-35, the Apache helicopter, and European programs, including SESAR and Clean Sky 2.

Founded in 1919, and employing some 650 people, NLR achieved a turnover of 71 million euros in 2016, of which three-quarters derived from contract research, and the remaining from government funds.

For more information visit: www.nlr.nl

RNAV Approach - Short Intercept

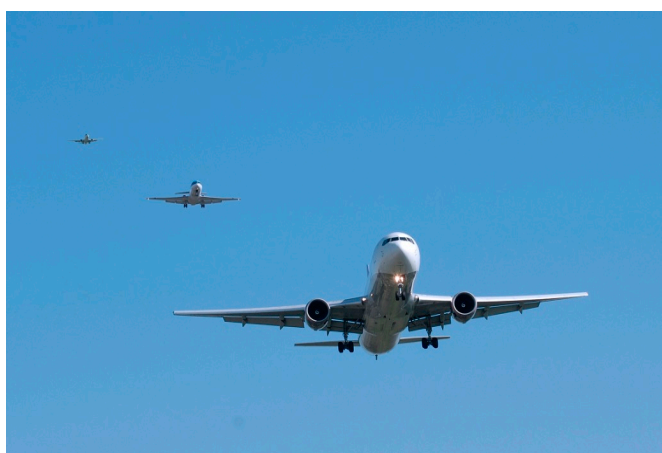

Problem area

To increase operational integrity, an RNAV approach can be published as a back-up for an existing ILS procedure, while still providing vertical guidance, with comparable minima and therefore without a large effect on the operational performance when in use.

However, there are some specific differences between an ILS approach and an RNAV approach. Operationally, the final approach altitude (FAA) and intercept point are to a large extent irrelevant on an ILS approach: another intercept point, or another intercept altitude, work equally well. An RNAV approach resides inside the Flight Management System (FMS) of the aircraft. Different aircraft architectures, FMS algorithms and operational procedures do not always provide a predictable set of circumstances for controllers and pilots. What may be an acceptable vector-to-final for one aircraft may not be acceptable for another.

REPORT NUMBER

NLR-CR-2017-160

AUTHOR(S)

A.K. Karwal
N. de Gelder
O.F. Bleeker

REPORT CLASSIFICATION

UNCLASSIFIED

DATE

May 2017

KNOWLEDGE AREA(S)

ATM and Airport Operation
Flight Operations

DESCRIPTOR(S)

RNP APCH
LNAV/VNAV
LPV
Intercept

Description of work

This report investigates certification/approval and regulatory aspects, operational flight crew procedures and FMS/autopilot architecture, and how these may possibly pose constraints on procedure design or operational use of vectors-to-final when vectored to a short approach. For validation and demonstration purposes a flight trial with the NLR Cessna Citation II, equipped with a Universal UNS1Fw FMS, was flown where the effect on aircraft guidance as a result of different short intercepts was investigated.

Results and conclusions

In general the following can be concluded from the findings of this report:

1. When vectoring an aircraft towards final for an RNAV approach, the aircraft must pass abeam the IF;
2. The Final Approach Fix (FAF) is a special waypoint in an RNAV approach and the aircraft must approach the final approach track 2 NM before the FAF, with an intercept angle of not more than 45°, and an XTE less than 1.6 NM;
3. The aircraft can intercept the vertical path at, below or above the published Final Approach Altitude (FAA). An intercept of the vertical path below the FAA will however not change the FAF and associated enabling/sequencing criteria of the RNAV approach. Therefore, vectoring to a lower altitude followed by a shorter intercept (i.e. inside the FAF) is not possible for RNAV approach operations contrary to ILS operations;
4. Intercepting the glide path from above is operationally not recommended;
5. To cater for possible discontinuities when transitioning from a barometric to a geometric path, ATC should clear the aircraft for approach when below the transition level and already flying on QNH.

Applicability

The results of this study are generally applicable to vector-to-final operations towards and RNAV approach to LPV, LNAV/VNAV or LNAV minima.

NLR

Anthony Fokkerweg 2

1059 CM Amsterdam

p) +31 88 511 3113 f) +31 88 511 3210

e) info@nlr.nl i) www.nlr.nl



Dedicated to innovation in aerospace

PUBLIC VERSION

NLR-CR-2017-160 | May 2017

RNAV Approach - Short Intercept

CUSTOMER: Air Traffic Control The Netherlands

AUTHOR(S):

A.K. Karwal
N. de Gelder
O.F. Bleeker

NLR
NLR
OFBleeker Consult

The er has granted NLR permission to publish this report.
 The contents of this report may be cited on condition that full credit is given to NLR and the author.

CUSTOMER	Air Traffic Control The Netherlands
CONTRACT NUMBER	68033
OWNER	NLR
DIVISION NLR	Aerospace Operations
DISTRIBUTION	Unlimited
CLASSIFICATION OF TITLE	UNCLASSIFIED

APPROVED BY :																			
AUTHOR							REVIEWER							MANAGING DEPARTMENT					
A.K. Karwal							P. van der Geest							A. Rutten					
DATE	2	5	0	4	1	7	DATE							DATE					

Summary

With the introduction of RNAV approaches new opportunities are given to procedure designers, controllers and pilots. Procedures can be designed with more flexibility; both the lateral and vertical path can be optimized for noise abatement and efficiency, leading to benefits for operators and environment. In addition, RNAV approaches do not require a ground infrastructure, leading to possible savings for service providers on maintenance of navigation aids. Safety is improved as well, as RNAV systems may provide both lateral and vertical guidance on final approach to any runway end, reducing the risk of a Controlled Flight Into Terrain (CFIT). To increase operational integrity, an RNAV approach with vertical guidance can be published as a back-up for an existing ILS procedure, with only slightly higher minima and therefore without a large effect on the operational performance when in use.

However, there are some specific differences between an ILS approach and an RNAV approach. An aircraft can intercept the ILS localizer, and glideslope, in principle at any point on the approach. When radar vectored, the aircraft can be vectored on a long or short final, the intercept logic and operational procedures in the cockpit are the same. Operationally, the final approach altitude (FAA) and intercept point are to a large extent irrelevant on an ILS approach: another intercept point, or another intercept altitude, work equally well, as long as certain minimum localizer intercept distances are taken into account. An RNAV approach resides inside the Flight Management System (FMS) of the aircraft. Different aircraft architectures, FMS algorithms and operational procedures do not always provide a predictable set of circumstances for controllers and pilots. What may be an acceptable vector-to-final for one aircraft may not be acceptable for another.

This report investigates certification/approval and regulatory aspects, operational flight crew procedures and FMS/autopilot architecture, and how these may possibly pose constraints on procedure design or operational use of vectors-to-final when vectored to a short approach, where any approach that intercepts the final track inside the Intermediate Fix (IF) or Final Approach Fix/Point (FAF/P) is considered a short approach. For validation and demonstration purposes a flight trial with the NLR Cessna Citation II, equipped with a Universal UNS1Fw FMS, was flown where the effect on aircraft guidance as a result of different short intercepts was investigated.

A review of existing ICAO, EASA, RTCA and FAA airworthiness and approval regulations show that not all intercepts are allowed. Although ATC will clear the aircraft for an “RNAV approach”, depending on aircraft equipment and operational approvals held by the operator and/or crew, the aircraft will fly an approach to LPV minima, to LNAV/VNAV minima (using either Baro-VNAV or GNSS/SBAS-VNAV¹), or to LNAV minima (without vertical guidance). Different criteria apply to aircraft guidance and (short) intercept capabilities for these procedures, affecting the possibility of using vector-to-final functionality, or the way that the FMS handles waypoint sequencing. Generally applicable to all types of RNAV approaches are the following:

- ATC tactical interventions in the terminal area may include radar headings to intercept the initial or intermediate legs of the approach;
- ‘Direct to’ clearances may be given to the IAF or IF, not to the FAF;
- The final approach trajectory should be intercepted no later than 2 NM before the FAF;

A review of operational procedures described for different aircraft and different FMS types reveal that there are different implementations of the regulations, especially in terminology. Common wording used include approach “activation”, “arming”, “loading”, “engagement”, “selection”, and more. Similarly, the FMS nomenclature uses the

¹ When the term SBAS is used in this document it is shorthand for GNSS/SBAS.

Final Approach Coarse Fix (FACF, or short CF), where approach plates may indicate Intermediate Fix (IF). The same word may mean something different with another manufacturer, or different terminology may refer to the same action in response to an ATC instruction. In general the following can be stated when reviewing operating procedures:

- All FMS types can accommodate a vector to intercept the final track outside the IF; most can accommodate a vector to intercept the final track between the IF and the FAF. There are no operating procedures available that describe how to intercept or what can happen when intercepting an approach when vectored inside the FAF.
- The approach segment is protected in the FMS. When manipulating the flight plan or flight plan waypoint attributes this leads to invalidation of the approach and loss of guidance or even inappropriate guidance. Depending on the FMS type the segment FAF-MAP is protected or in some cases the segment IF-MAP.
- Vertically there are some differences in the way the FMS constructs a path before the IF, between the IF and FAF, and passed the FAF. The final approach segment is always a geometric path with a prescribed angle, other segments may use other ways of defining the VNAV path.
- For LPV approaches, the transition from a barometric altitude to an earth-fixed geometric path may introduce some discontinuities with extreme QNH values or temperatures. To avoid these issues, the aircraft should intercept the final approach path when already flying at an altitude.
- All guidance systems can cater for an intercept from above the glide path and most operators describe operational procedures for this event, but operationally this is not recommended.

Different combinations of FMS and Aircraft Flight Guidance and Control Systems (AFGCS) have been reviewed in context of RNAV approach operations. In general the logic applied in selecting and activating the desired approach including transitioning from 'en-route' to 'terminal' operations and subsequently from terminal operations to approach operations are found to be fully comparable. Some differences occur in the detailed logic associated with enabling/activation/capturing of the approach path, but in general the analogy with ILS operation can be made. If approach leg sequencing does not take place because the logic conditions are not met, then the aircraft will continue to operate in its previous navigation guidance function.

In order to achieve orderly approach trajectory interception and tracking there are special criteria for the FAF to sequence, i.e. for the approach path between FAF and MAP to become active, in deviation from standard waypoint sequencing criteria (passing abeam, or passing the turn bisector). This limits the way that the final segment must be intercepted and the margins in which the FAF has to be overflowed.

A test flight with the NLR Citation II, equipped with a Universal UNS1Fw FMS, was performed at Eelde on March 22. A test matrix was drafted aimed at investigating the influence of intercept angle, intercept altitude, and intercept distance, and SBAS versus Baro-VNAV. The flight test results may in detail not be valid for all aircraft/FMS combinations, but in general demonstrated that:

1. A short line-up can lead to operational problems for the flight crew because the final approach may not be the active leg due to waypoint sequencing rules. Correct guidance was only available if the aircraft had passed abeam the IF during the line-up;
2. There are no problems intercepting the vertical path at lower or higher altitudes than the published final approach altitude.

In general the following can be concluded from the findings of this report:

1. When vectoring an aircraft towards final for an RNAV approach, the aircraft must pass abeam the IF;

- The FAF is a special waypoint and the aircraft must approach the FAF within certain margins. These margins are that the aircraft must approach the final approach track 2 NM before the FAF, with an intercept angle of not more than 45° , and an XTE less than 1.6 NM, see figure below;

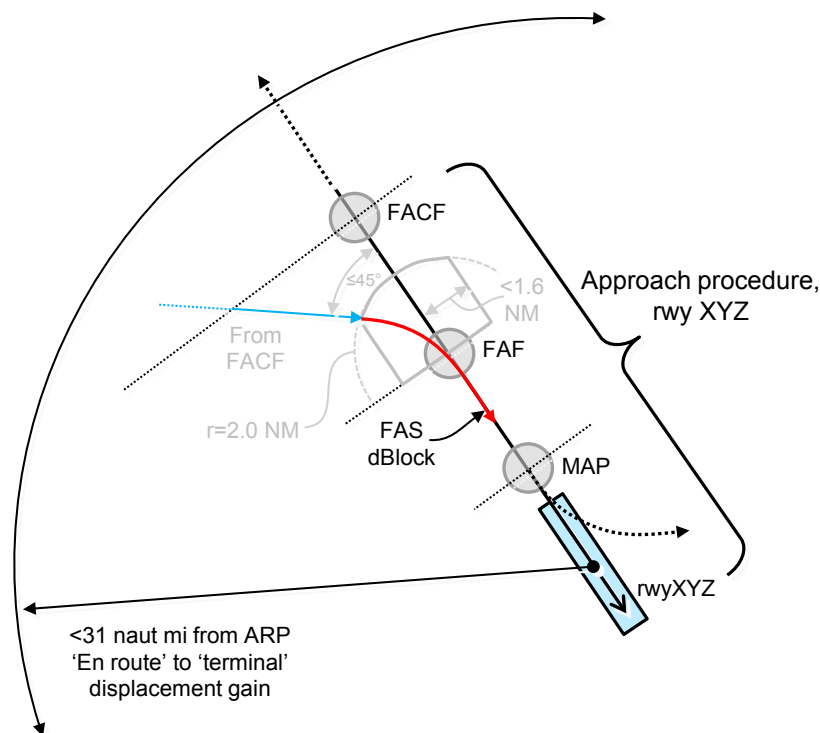

Limitations in approaching the FAF

- The aircraft can intercept the vertical path at, below or above the published Final Approach Altitude (FAA), but the aircraft altitude must be less than 3000 feet above the FAF altitude constraint. An intercept of the vertical path below the FAA will however not change the FAF and associated enabling/sequencing criteria of the RNAV approach. Therefore, vectoring to a lower altitude followed by a shorter intercept (i.e. inside the FAF) is not possible for RNAV approach operations contrary to ILS operations;
- Intercepting the glide path from above is operationally not recommended;
- A clearance for an RNAV approach means the crew can decide, depending on aircraft equipment and operational conditions and approvals, if it will fly the vertical path using SBAS or Baro-VNAV, or without vertical guidance. To cater for possible discontinuities (in case of using SBAS) when transitioning from a barometric to a geometric path, ATC should clear the aircraft for approach when below the transition level and already flying on QNH.



Contents

Acronyms	9
1 Introduction	13
2 Review of material	15
2.1 Approvals/Certification and Regulations	15
2.1.1 ICAO Doc 9613, PBN Manual	15
2.1.2 EASA	17
2.1.3 FAA	20
2.1.4 RTCA DO-229E	21
2.1.5 ICAO Doc 8168 PANS OPS	24
2.2 Operational Procedures	25
2.2.1 Airbus	25
2.2.2 Boeing	28
2.2.3 Embraer	30
2.2.4 Universal FMS	31
2.2.5 Collins FMS	32
2.2.6 Garmin	33
2.2.7 Overview	34
2.3 Aircraft Equipment	35
2.3.1 Aircraft Navigation Guidance and Control functions	35
2.3.2 Approach operations	36
2.3.3 Reference trajectory construction	43
2.3.4 FMS RNAV approach 'procedure'	45
2.3.5 FMS RNAV approach enabling and capturing conditions	45
2.3.6 FAF sequencing criteria	47
3 Analysis	48
3.1 Findings from Approvals/Certification & Regulations	48
3.2 Findings from Citation Flight Test	49
3.3 Findings from Aircraft Systems	51
3.3.1 FMS, differences between manufacturer	51
3.3.2 Summary	52
4 Conclusions and Recommendations	53
5 References	54
Appendix A Approach Charts EHGG	56

Appendix B	Flight Test Results	59
Appendix B.1	Run 1 - Nominal	59
Appendix B.2	Run 2 – 45° intercept	60
Appendix B.3	Run 3 – Intercept inside the FAF (BaroVNAV)	61
Appendix B.4	Run 4 – Intercept inside the FAP (SBAS)	63
Appendix B.5	Run 5 – Intercept outside the IF (Baro VNAV)	64
Appendix B.6	Run 6 - Intercept outside the IF (SBAS)	65
Appendix B.7	Run 7 – Intercept outside the IF, auto-activation (BaroVNAV)	66
Appendix B.8	Run 8 - Intercept outside the IF, auto-activation (SBAS)	67
Appendix B.9	Run 9 - 45° intercept (headwind)	68
Appendix B.10	Run 10 – Long intercept inside FAF	69
Appendix B.11	Run 11 - 45° intercept (tailwind, localizer)	70

Acronyms

ACRONYM	DESCRIPTION
AC	Advisory Circular
AEEC	Airlines Electronic Engineering Committee
AFGCS	Automatic Flight Guidance and Control System
AGL	Above Ground Level
AMC	Acceptable Means of Compliance
AOC	Air Operator Certificate
AOM	Aircraft Operating Manual
APP, APPR	Approach
APV	Approach Procedure with Vertical guidance
ARP	Airport Reference Point
ATC	Air Traffic Control
ATIS	Automatic Terminal Information Service
AWO	All Weather Operations
Baro-VNAV	Barometric Vertical Navigation
CAT	Category
CF	Course to a Fix
CRC	Cyclic Redundancy Check
CS-ACNS	Certification Specification – Airborne Communications, Navigation and Surveillance
CFIT	Controlled Flight Into Terrain
EASA	European Aviation Safety Agency
EGNOS	European Geostationary Navigation Overlay Service
ETSO	European Technical Standard Order
FAA	Federal Aviation Administration; Final Approach Altitude
FACF	Final Approach Course Fix
FAF	Final Approach Fix
FAP	Final Approach Point
FAS	Final Approach Segment
FAWP	Final Approach Waypoint
FBW	Fly-By-Wire
FCOM	Flight Crew Operating Manual
FCS	Flight Control System
FCTM	Flight Crew Training Manual
FMC	Flight Management Computer
FMS	Flight Management System

FPAP	Flight Path Alignment Point
FSD	Full-Scale Deflection
FTE	Flight Technical Error
FTP	Fictitious Threshold Point
GA	General Aviation
GBAS	Ground-Based Augmentation System
GLS	GNSS/GBAS Landing System
GNSS	Global Navigation Satellite System
GP	Glide Path
GPA	Glide Path Angle
GPS	Global Positioning System
HW	Hardware
IAC	Instrument Approach Chart
IAF	Initial Approach Fix
IAN	Integrated Approach Navigation
IAP	Instrument Approach Procedure
ICAO	International Civil Aviation Organization
IF	Intermediate Fix
ILS	Instrument Landing System
ISA	International Standard Atmosphere
IWP	Intermediate Waypoint
LDA	Localizer-type Directional Aid
LNAV	Lateral Navigation
LORAN	Long Range Navigation system
LoS	Level of Service
LP	Localizer Performance
LPV	Localizer Performance with Vertical guidance
LTP	Landing Threshold Point
LVNL	Luchtverkeersleiding Nederland (Air Traffic Control The Netherlands)
MAPt, MAP	Missed Approach Point
MAWP	Missed Approach Waypoint
MDA	Minimum Descent Altitude
MLS	Microwave Landing System
MMR	Multi-Mode Receiver
MSL	Mean Sea Level
NAV	Navigation
NDB	Non-Directional Beacon

NLR	Netherlands Aerospace Centre
NPA	Non Precision Approach
NSC	No Significant Cloud
OM	Outer Marker
PA	Precision Approach
PAR	Precision Approach Radar
PBN	Performance Based Navigation
RNAV, RNV	Area Navigation
RNP	Required Navigation Performance
RNP APCH	Required Navigation Performance Approach
RNP AR	Required Navigation Performance Authorisation Required
RWY	Runway
SBAS	Satellite-Based Augmentation System
SOP	Standard Operating Procedure
STAR	Standard Arrival Route
SW	Software
TAWS	Terrain Awareness and Warning System
TCH	Threshold Crossing Height
TCP	Trajectory Change Point
TF	Track to a Fix
THR	Threshold
TKE	Track Angle Error
TRANS	(Approach) Transition
TSE	Total System Error
TSO	Technical Standard Order
VAL	Vertical Alert Limit
VDA	Vertical Descent Angle
VDEV	Vertical Deviation
VHF	Very High Frequency
VNAV	Vertical Navigation
VOR	VHF Omnidirectional Radio Range
VTF	Vector To Final
WAAS	Wide Area Augmentation System
WGS	World Geodetic System
WPT	Waypoint
XTE	Cross-Track Error

This page is intentionally left blank.

1 Introduction

With the introduction of RNAV approaches new opportunities are given to procedure designers, controllers and pilots. Procedures can be designed with more flexibility; both the lateral and vertical path can be optimized for noise abatement and efficiency, leading to benefits for operators and environment. In addition, RNAV approaches do not require a local ground infrastructure, leading to savings for service providers on maintenance of navigation aids. Safety is improved as well, as RNAV systems may provide a near-ILS precision approach path with both lateral and vertical guidance on final approach to any runway end, reducing the risk of a Controlled Flight Into Terrain (CFIT).

Since the early days of instrument flying, the ILS has been an extremely reliable and accurate system for final approach navigation, both vertically and laterally. The (analog) system behaviour and anomalies are well understood, aircraft guidance systems capable of capturing and tracking localizer and glideslope signals have been certified up to automatic landing in zero visibility, and operational procedures are well-established and routinely used by controllers and pilots around the world.

However, RNAV approaches are different in that respect. The approach does not use relative navigation signals and resides inside the FMS. Although standards exist, absolute position determination and corresponding guidance to control the aircraft along a certain reference trajectory is created by the FMS using proprietary algorithms. Different FMS types and different sensors may yield different guidance and therefore different behaviour during the capture and tracking phases of the approach, both lateral and vertical.

An ILS approach emits a lateral (localizer) and vertical (glideslope) beam that is usable to a maximum of approximately 30 NM. An aircraft can intercept the localizer, and glideslope, in principle at any point on the approach. When radar vectored, the aircraft can be vectored on a long or short final, the intercept logic and operational procedures in the cockpit are the same. Operationally, the final approach altitude (FAA) and intercept point are to a large extent irrelevant on an ILS approach: another intercept point, or another intercept altitude, work equally well, as long as certain minimum localizer intercept distances are taken into account.

On an RNAV approach this may not be the case. Different aircraft architectures, FMS algorithms and operational procedures do not always provide a predictable set of circumstances for controllers and pilots. What may be an acceptable vector-to-final for one aircraft may not be acceptable for another.

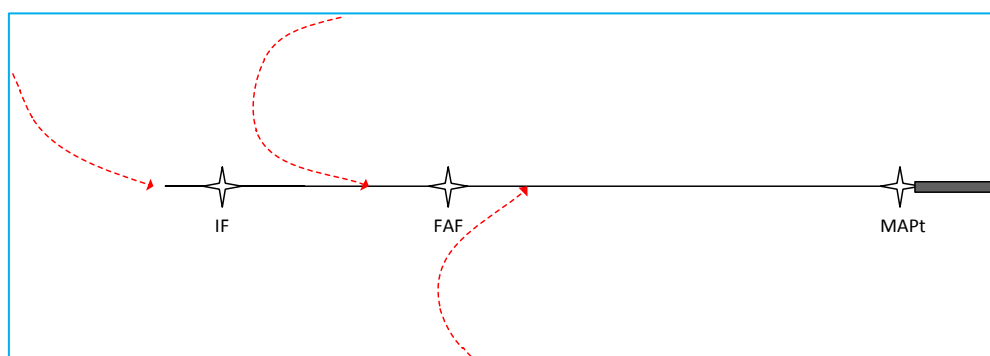

The picture shows some of the possible lateral intercepts of the final approach azimuth from radar vectors. The intercept may be located before the IF, between the IF and FAF and after the FAF.

Vertically, the elevation (glidepath) may be intercepted at, above or below the published Final Approach Altitude. The glidepath may be defined as a barometric path (slope depends on temperature) or a geometric path using SBAS.

This report looks into the following aspects of vectoring to a short final approach:

- What do the regulations state about different intercept possibilities? (Section 2.1)
- Do aircraft operating procedures allow short intercepts? (Section 2.2)
- Can aircraft guidance systems cope with short intercepts? (Section 2.3)

A flight test with the NLR Citation II equipped with a Universal UNS1Fw Flight Management System was performed, where different lateral and vertical intercepts were attempted towards an RNAV (LNAV/VNAV or LPV) approach.

2 Review of material

2.1 Approvals/Certification and Regulations

This section provides an overview of criteria from standards and regulations that are relevant to the intercept of RNAV Approach (RNAV APCH) operations down to LNAV/VNAV and LPV minima.

The following documents have been reviewed:

- [1] ICAO Doc 9613, PBN Manual, 4th Edition
- [2] EASA AMC 20-27, Airworthiness Approval and Operational Criteria for RNP APPROACH (RNP APCH) Operations Including APV BARO-VNAV Operations
- [3] EASA AMC 20-28, Airworthiness Approval and Operational Criteria related to Area Navigation for Global Navigation Satellite System approach operation to Localiser Performance with Vertical guidance minima using Satellite Based Augmentation System
- [4] EASA Certification Memorandum CM-AS-002, Issue: 02, Clarifications to AMC 20-27
- [5] EASA Air Operations Regulation, EASA Decisions 2016/014/R to 2016/021/R
- [6] FAA AC 20-138D, Change 2, Airworthiness Approval of Positioning and Navigation Systems
- [7] FAA AC 90-105A, Approval Guidance for RNP Operations and Barometric Vertical Navigation in the U.S. National Airspace System and in Oceanic and Remote Continental Airspace
- [8] FAA AC 90-107, Guidance for Localizer Performance with Vertical Guidance and Localizer Performance without Vertical Guidance Approach Operations in the U.S. National Airspace System
- [9] RTCA DO-229E, Minimum Operational Performance Standards for Global Positioning System/Satellite-Based Augmentation System Airborne Equipment
- [10] RTCA DO-283B, Minimum Operational Performance Standards for Required Navigation Performance for Area Navigation
- [11] ICAO Doc 8168, Procedures for Air Navigation Services Aircraft Operations (PANS OPS), Volume I Flight Procedures, 5th Edition up to and including amendment 7.

Typically, EASA and FAA airworthiness regulations refer, to a large extent, to criteria included in Technical Standard Orders (ETSO/TSO). These ETSOs/TSOs again refer to requirements in EUROCAE/RTCA documents.

For example, AMC 20-27 refers to equipment qualifications set forth in ETSO-C146/TSO-C146 and ETSO-C145/TSO-C145 and these ETSOs/TSOs again refer to standards set forth in RTCA document DO-229D.

2.1.1 ICAO Doc 9613, PBN Manual

Chapter 5 in Volume II of the ICAO PBN Manual describes standards regarding implementation of RNP APCH. It contains two sections: the first section describes RNP APCH Operations down to LNAV and LNAV/VNAV minima and the second section describes RNP APCH Operations down to LP and LPV minima. One of the main differences is that RNP APCH Operations down to LP and LPV minima are based on augmented GNSS, in practice this means that SBAS is required.

The ICAO standard for RNP APCH is mainly based on the advisory material from EASA and FAA.

2.1.1.1 Functional Criteria related to intercepting RNP APCH procedures

RNP APCH Operation down to LNAV/VNAV minima may be flown with augmented GNSS (i.e., SBAS) provided that the installation complies with either the requirements for Baro-VNAV or the requirements for RNP Operations down to LPV minima.

It is important to note the requirements for LNAV/VNAV are based on linear lateral and vertical deviations for both monitoring and steering, whereas for LPV the requirements are based on lateral and vertical deviations equivalent to ILS. Therefore, aircraft equipped with SBAS (enabling operations down to LPV minima) will have a different method of monitoring and steering compared to aircraft not equipped with SBAS.

LNAV, LNAV/VNAV

- The lateral deviation display must have a full-scale deflection ('displacement gain') suitable for the current phase of flight and must be based on the TSE requirement. Scaling is ± 1 NM for the initial and intermediate segments and ± 0.3 NM for the final segment.
- The navigation system must provide the capability to continuously display to the pilot flying the aircraft position relative to the vertically defined path. The display must allow the pilot to readily distinguish if the vertical deviation exceeds +22 m/-22 m (+75 ft/-75 ft).
- A 'vector to final' function is not required.
- Waypoint sequencing has to be automatic. No specific sequencing criteria have been defined.
- Baro-VNAV is intended to be applied where vertical guidance and information are provided to the pilot on IAPs containing a vertical flight path defined by a vertical path angle. Baro-VNAV may also be defined by altitude constraints but only for flight phases other than approach.

LPV

- The deviation display must have a suitable full-scale deflection based on the required track-keeping accuracy.
- The lateral and vertical full scale deflection are angular and associated to the lateral and vertical definitions of the Final Approach Segment (FAS) contained in the FAS data block.
- The capability to immediately provide track deviation indications relative to the extended FAS, in order to facilitate the interception of the extended FAS from a radar vector (e.g. VTF function).
- Waypoint sequencing is not applicable.

2.1.1.2 Operational Criteria related to intercepting RNP APCH procedures

The following criteria are listed in relation to operational procedures for LNAV, LNAV/VNAV as well as LPV:

- ATC tactical interventions in the terminal area may include radar headings, "direct to" clearances which bypass the initial legs of an approach, interception of an initial or intermediate segment of an approach, or the insertion of waypoints loaded from the database. In complying with ATC instructions, the pilot should be aware of the implications for the RNP system:
 - a) The manual entry of coordinates into the RNP system by the pilot for operation within the terminal area is not permitted; and
 - b) "Direct to" clearances may be accepted to the IF provided that the resulting track change at the IF does not exceed 45 degrees.

Note - "Direct to" clearance to FAF/FAP is not acceptable.

LNAV, LNAV/VNAV specific criteria

- The lateral definition of the flight path between the FAF and the MAPt must not be revised by the pilot under any circumstances.
- The aircraft must be established on the final approach course no later than the FAF before starting the descent (to ensure terrain and obstacle clearance).
- When Barometric VNAV is used for vertical path guidance during the FAS, deviations above and below the Barometric VNAV path must not exceed +22 m/–22 m (+75 ft/–75 ft), respectively.

LPV specific criteria

- The approach system provides the capability for the pilot to intercept the final approach track well before the FAP (VTF function or equivalent). This function should be used to respect a given ATC clearance.
- The approach mode will be activated automatically by the RNP system. When a direct transition to the approach procedure is conducted (e.g. when the aircraft is vectored by the ATC to the extended FAS and the crew selects the VTF function or an equivalent function), the LPV approach mode is also immediately activated.
- The system provides lateral and/or vertical guidance relative to the LPV FAS or to the extended FAS (for the direct transition).
- The FAS should be intercepted no later than the FAP in order for the aircraft to be correctly established on the final approach course before starting the descent (to ensure terrain and obstacle clearance).

2.1.2 EASA

Various EASA documents are related to RNP APCH Operations. For airworthiness criteria, one should look at the AMCs, in particular AMC 20-27, AMC 20-28 and Certification Memorandum CM-AS-002, the latter is a clarification of AMC 20-27. For operational criteria, the Air Operations Regulations should be considered. Note that the AMCs also include operational criteria, but these are superseded by the Air Operations Regulations.

It is worthwhile to mention that EASA is drafting an update of the CS-ACNS, which will include RNP airworthiness criteria and will therefore in the future replace the material in the AMCs. It is expected that the new CS-ACNS material addressing RNP APCH is largely based on the two AMCs and CM-AS-002.

The AMCs refer, to a large extent, to ETSO-C145/TSO-C145 and ETSO-C146.TSO-C-146. These TSOs in turn refer to RTCA DO-229D. Therefore, the minimum performance standards of DO-229D are part of the airworthiness criteria via this mechanism.

2.1.2.1 Functional Criteria related to intercepting RNP APCH procedures

2.1.2.1.1 AMC 20-27 – RNP APCH including Baro-VNAV

Along a required function on the navigation data base, the following note is written:

- Note: When a procedure is loaded from the database, the RNAV system is required to fly it as published. This does not preclude the flight crew from having the means to modify a procedure or route already loaded into the RNAV/GNSS system as permitted by the RNP APCH Operational Criteria.

Recommended functions are:

- Capability, following ATC instructions, to immediately provide horizontal track deviation indications relative to the extended final approach segment, in order to facilitate the interception of this extended final approach segment from a radar vector (Vector To Final (VTF) function).
- Capability to automatically intercept the vertical path at FAP using a vertical flyby technique.

2.1.2.1.2 AMC 20-28 - LPV

AMC 20-28 requires that GNSS augmented by SBAS is the primary navigation system to support LPV approach operations.

Required functions are:

- The lateral and vertical Full Scale Deflections are angular and associated to the lateral and vertical definitions of the FAS contained in the FAS Data Block.
- Capability to immediately provide indications of deviation from the intended flight path relative to the extended final approach segment. Note: This is to facilitate the interception of the extended final approach segment from a radar vector (e.g. Vector To Final (VTF) function).

2.1.2.1.3 CM-AS-002 – Clarifications to AMC 20-27

This EASA Certification Memorandum provides clarifications in a number of areas; one of these areas is the use of GNSS/SBAS geometric altitude as source for approach to LNAV/VNAV minima.

When AMC 20-27 was drafted, it was assumed that vertical navigation (VNAV) would be based on barometric altitude. Industry standards, like RTCA DO-229C (and later revisions), however contained provisions which would enable SBAS capable GNSS receivers to provide steering commands and guidance data on approaches to LNAV/VNAV minima.

A required function is:

- The deviation display must have a suitable full-scale deflection based on the required lateral and vertical track keeping accuracy.

In order for an approach to LNAV/VNAV minima to be flown with VNAV guidance based on GNSS/SBAS geometric altitude, the angular nature of the guidance should have been taken into account in the procedure design. States publishing the approach should explicitly declare whether or not angular guidance has been accounted for in the approach design. Where approaches with angular guidance can be used, this is indicated by the database provider by coding an approach with the character 'A' in the ARINC 424 GNSS/FMS indicator field of the navigation database.

Because BARO-VNAV will be in use for most flight phases, including missed approach, there will be a need for a smooth transition from BARO-VNAV to GNSS/SBAS-VNAV and vice versa.

Another area, in which clarification is provided, is the provisioning of steering and monitoring signals with barometric angular vertical deviations as opposed to the linear deviations assumed in AMC 20-27.

Options are:

- The angular deviation is provided within the vertical boundaries of the 'standard' linear approach to LNAV/VNAV minima, or

- The angular deviation complies with a Full Scale Deflection (FSD) of $\pm 0.25 \times$ (glide path angle), as defined in RTCA DO-229D.

2.1.2.2 Operational Criteria related to intercepting RNP APCH procedures

The Air Operations Regulations has acceptable means of compliance and guidance material (AMC and GM) for specific kind of operations, for example AMC and GM to Part-CAT addresses Commercial Air Transport Operations.

The following AMC and GM on air operations include operational criteria related to RNP APCH:

Part-CAT	Commercial Air Transport Operations.
Part-NCO	Non-commercial operations with other than complex motor-powered aircraft.
Part-NCC	Non-commercial operations with complex motor-powered aircraft.
Part-SPO	Specialised Operations.

The criteria related to RNP APCH are similar for all above-mentioned Parts.

The relevant operational criteria are:

- The lateral and vertical definition of the flight path between the FAF and the missed approach point (MAPt) retrieved from the database should not be revised by the flight crew.
- ATC tactical interventions in the terminal area may include radar headings, 'direct to' clearances which bypass the initial legs of an approach procedure, interceptions of an initial or intermediate segments of an approach procedure or the insertion of additional waypoints loaded from the database.
- In complying with ATC instructions, the flight crew should be aware of the implications for the navigation system.
- 'Direct to' clearances may be accepted to the IF provided that it is clear to the flight crew that the aircraft will be established on the final approach track at least 2 NM before the FAF. [Note: this effectively limits the resulting track change at the IF based on the distance between IF and FAF].
- 'Direct to' clearance to the FAF should not be acceptable. Modifying the procedure to intercept the final approach track prior to the FAF should be acceptable for radar-vector arrivals or otherwise only with ATC approval.
- The final approach trajectory should be intercepted no later than the FAF in order for the aircraft to be correctly established on the final approach track before starting the descent (to ensure terrain and obstacle clearance). Note: other documents prescribe that aircraft must approach the final approach track 2 NM before the FAF.
- Deviations below the vertical path should not exceed 75 ft at any time, or half-scale deflection where angular deviation is indicated, and not more than 75 ft above the vertical profile, or half-scale deflection where angular deviation is indicated, at or below 1000 ft above aerodrome level. The flight crew should execute a missed approach if the vertical deviation exceeds this criterion, unless the flight crew has in sight the visual references required to continue the approach.
- Cross-track error/deviation (the difference between the area-navigation-system-computed path and the aircraft-computed position) should normally be limited to $\pm \frac{1}{2}$ time the RNAV/RNP value associated with the procedure. Brief deviations from this standard (e.g. overshoots or undershoots during and immediately after turns) up to a maximum of 1 time the RNAV/RNP value should be allowable.

2.1.3 FAA

2.1.3.1 Functional Criteria related to intercepting RNP APCH procedures

2.1.3.1.1 AC 20-138D

Relevant airworthiness criteria are:

- For LNAV/VNAV approaches collocated with LPV approaches, GPS/SBAS equipment must use the final approach segment (FAS) data block to define the final approach segment as described in RTCA/DO-229D, Change 1. But, a FAS data block is not provided for LNAV/VNAV approaches that are not collocated with an LPV approach. The vertical path for such approaches is defined by the threshold location, threshold crossing height, and glidepath angle. However, the altitude of the threshold is published as the height above/below mean sea level (MSL), rather than as the height above/below the WGS-84 ellipsoid. The latter is needed when using GPS/SBAS equipment for vertical guidance. Therefore, when using GPS/SBAS equipment, the published MSL height (interpreted as a height above/below the WGS-84 geoid) must be converted to height above/below the WGS-84 ellipsoid prior to being used.
- Receiver manufacturers may consider performing the conversion within the GPS/SBAS equipment or using a database process that provides threshold crossing height directly as height above/below the WGS-84 ellipsoid for GPS/SBAS approaches. However, GPS/SBAS integrations with baro-VNAV will need to address the issue of WGS-84 ellipsoid versus MSL height. This can be done through conversion or storing threshold data as both WGS-84 ellipsoid and MSL height to use for GPS/SBAS or baro-VNAV as appropriate.
- GPS/SBAS and GPS/GBAS sensors can be approved on aircraft without baro-VNAV to provide vertical path guidance for RNAV approaches down to LNAV/VNAV or LPV minima.
- GNSS is the primary navigation system to support RNP approach procedures.
- When constructing the descent path for the final approach segment of an RNP instrument approach procedure, the RNP equipment must always use the procedure-defined flight path angle.
 - Note: RNP instrument approach procedures may have a final approach fix with an 'AT' altitude constraint. The intent of the guidance is to use the published flight path angle for descent path construction. This is to ensure geometric point-to-point between two 'AT' constraints is not used for the final approach segment.
- The lateral deviation display must have a full-scale deflection suitable for the current phase of flight and must be based on the TSE requirement. Scaling of ± 1 NM for the initial, intermediate, and missed approach segments and ± 0.3 NM for the final segment is acceptable. It is also acceptable for the scaling to be more conservative than the TSE; for example, ± 0.3 NM for the initial, intermediate, and missed approach segments. However, the final approach segment scaling must not be smaller than 0.3 NM (not applicable to RNP AR, LP/LPV, GLS, or when using RTCA/DO-229() angular scaling).
- Note: GPS/SBAS Class 2 and Class 3 as well as GPS/GBAS vertical positioning performance exceeds the accuracy requirements of a barometric sensor used for final approach VNAV. The GPS/SBAS 50m Vertical Alert Limit (VAL) used for LNAV/VNAV is consistent with baro-VNAV and may also be used to comply with RNP approach.
- Baro VNAV systems using angular vertical scaling must meet the following:
 - The deviation scaling supports the FTE monitoring and bounding (75 ft deviation below path).
 - Note: This may require limiting the length of the approach to exclude operating where the angular deviations no longer support FTE monitoring and bounding.

- The deviation limits are equivalent to the operational limits for glideslope deviations during an ILS approach.
- Issues with transitioning from GPS/SBAS to baro-VNAV vertical guidance on the final approach segment include:
 - Temperature errors, particularly if the GPS/SBAS approach was started outside the allowable baro-VNAV temperature range.
 - MSL versus WGS-84 ellipsoid for path definition.
 - Quasi-straight geometric path for baro-VNAV versus fully-straight geometric path for SBAS-VNAV.
 - Linear baro-VNAV guidance versus angular GPS/SBAS guidance.

2.1.3.2 Operational Criteria related to intercepting RNP APCH procedures

2.1.3.2.1 AC 90-105A

Nothing new concerning the RNAV Approach intercept in comparison with the material above.

2.1.3.2.2 AC 90-107

Nothing new concerning the RNAV Approach intercept in comparison with the material above.

2.1.4 RTCA DO-229E

Relevant RNAV/RNP equipment requirements in DO-229E are:

- The equipment shall provide the ability to edit the flight plan, including the ability to insert or delete any waypoint in the flight plan other than those waypoints which are part of a published procedure (departure, arrival, approach). For those waypoints which are part of a published procedure, the equipment shall provide the capability to bypass waypoints or proceed to a waypoint not part of the published procedure. Modifying the final approach segment (i.e., inserting a waypoint between the FAWP and MAWP or bypassing the FAWP or MAWP) shall disable the approach mode.
- Leg sequencing
 - If cross-track deviations are provided relative to a curved path through the turn at a waypoint and the estimated position is within the theoretical transition area, the waypoint shall be sequenced when the estimated position crosses the bisector of the angle defined by the leg on either side of the waypoint.
 - If cross-track deviations are not provided relative to a curved path through the turn at a waypoint, the waypoint shall be sequenced at the turn initiation point and deviations provided relative to the extension of the next leg.
 - For VNAV guidance, vertical deviations are based upon sequencing to the next leg at the bisector. Therefore, sequencing at the turn initiation point is not acceptable for VNAV.
- Approach mode switching
 - VTF has been selected; or all of the following conditions are true:
 - On an approach procedure;
 - and the FAWP, MAWP (LTP/FTP), or the first waypoint in the missed approach procedure is the active waypoint and prior to the turn initiation point (the first waypoint in the missed

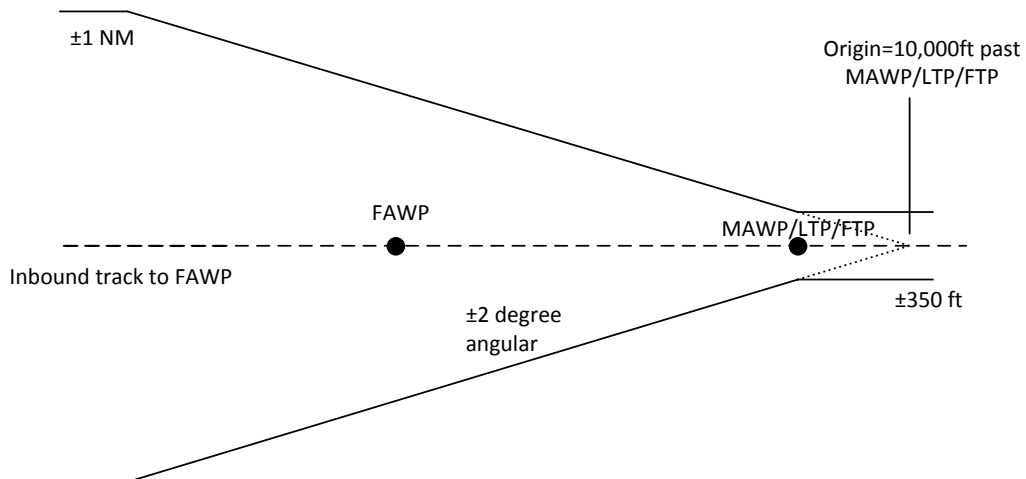

Figure 2-2: Full scale deflection and defined path for LNAV VTF approach

- Vertical Path for NPA Procedures
 - The equipment may provide a vertical path and display vertical deviations for non-precision approach procedures. When this capability is provided, then the vertical path shall be defined as described for LNAV/VNAV approaches.
- Non-Numeric Cross-Track Deviation
 - The full-scale deflection for non-precision approach mode shall either be identical to the precision approach mode (only possible for procedures with FAS path definition records); or shall be as follows:
 - If a VTF approach has not been selected:
 - Prior to 2 nm from the FAWP, the FSD shall be 1 nm;
 - Between 2 nm from the FAWP and the FAWP, the FSD shall gradually change to the FSD specified in (c) below at the FAWP;
 - At and beyond the FAWP, but before initiating a missed approach, the full-scale deflection shall be the minimum of: constant FSD of ± 0.3 Nautical Miles (NM); or angular Full-Scale Deflection (FSD) defined by a ± 2.0 degree wedge with origin located 10,000 feet past the MAWP. The FSD shall continue to decrease or shall reach a minimum of ± 350 feet. See Figure 2-12 for an illustration of the linear sensitivity close to the runway.
 - If a Vector-to-Final (Approach) (VTF) has been selected, the FSD shall be the minimum of: constant FSD of 1 nm; or angular FSD defined by a ± 2.0 degree wedge with origin located 10,000 feet past the Missed Approach Waypoint (MAWP). The FSD shall continue to decrease or shall reach a minimum of 350 feet. See Figure 2-13 for an illustration of the linear sensitivity close to the runway.
- Display Transition Requirements
 - Upon entering the nonprecision approach mode when a VTF has not been selected, there is no change in FSD until the aircraft reaches a distance of 2 nm from the FAWP.
 - Upon entering the nonprecision approach mode when a VTF has been selected, the equipment shall immediately transition to the angular/linear guidance relative to the (extended) FAS.
 - Note: The approach sensitivity at the FAWP depends upon the length of the final approach segment. It will be the minimum of ± 0.3 nm and the angular splay illustrated in DO-229E Figure 2-12.

- The requirements below apply to WAAS equipment, which provides vertical deviations for LNAV/VNAV approaches.
 - For procedures defined by a FAS data block, the final approach path shall be defined by the Flight Path Alignment Point (FPAP) and Landing Threshold Point/Fictitious Threshold Point (LTP/FTP), and by the Threshold Crossing Height (TCH) and glidepath angle. The threshold location is referred to as the LTP if it is collocated with the runway and FTP if it is displaced from the runway. The glidepath angle is defined relative to the local tangent plane of the WGS-84 ellipsoid.
 - The final approach path for standalone LNAV/VNAV approaches (without a FAS data block) is defined by the intersection of the non-precision approach lateral path with the vertical path defined by the threshold location, threshold crossing height, and glidepath angle.
 - For standalone LNAV/VNAV approaches, the azimuthal alignment is defined by the vector from the FAWP to the MAP, rather than the LTP/FTP and the FPAP.

2.1.5 ICAO Doc 8168 PANS OPS

Nothing new is described in Doc 8168 concerning the RNAV approach intercept in comparison with to the material above.

2.2 Operational Procedures

This section describes some of the standard operational procedures currently published for a number of aircraft and FMS types. It is important to realise that such an overview cannot be complete with a multitude of different aircraft options, FMS types and options and operator procedures around. However, a general overview is given based on aircraft and FMS manufacturer using the following breakdown:

1. AOC operations with Transport Category Aircraft
 - a. Airbus (Thales, Honeywell)
 - b. Boeing (GE/Smiths for 737NG, Honeywell for 747, 777 and 787)
 - c. Embraer (Honeywell)

2. GA operations, small and medium size aircraft
 - a. Universal UNS
 - b. Collins
 - c. Garmin

The review will investigate possible restrictions for lateral intercepts, vertical intercepts, and use of the autopilot approach mode (if available). For the review reference is made to both the Aircraft Operating Manual (AOM) and Flight Crew Training Manual (FCTM) for Transport Category Aircraft, and the FMS Pilot's Operating Manual for GA operations.

2.2.1 Airbus

The Airbus fleet is highly standardized with respect to standard operational procedures. Instructions valid for the A318/319/320/321 are almost identical to those applied on the A330/340 and later models A380 and A350. [12] [13] [14] [15] [16]

Airbus aircraft typically are equipped with either a Honeywell or Thales FMS, but both implementations are almost identical: the pilot cannot easily determine which FMS type is installed.

2.2.1.1 Lateral path

For lateral intercepts, the Airbus FCTM addresses the potential for inappropriate leg sequencing by instructing the crew to keep the flight plan up-to-date when vectored to final approach:

INTERCEPTION OF FINAL APPROACH COURSE

It is essential to have a correct F-PLN in order to ensure proper final approach guidance. Indeed the NAV and APPR NAV modes are always guiding the aircraft along the F-PLN active leg and the managed vertical mode ensures VDEV = 0, VDEV, being computed along the remaining F-PLN to destination. Hence, the crew will monitor the proper sequencing of the F-PLN, more specifically if HDG mode is selected, by checking that the TO WPT, on upper right hand corner of ND, is the most probable one and meaningful.

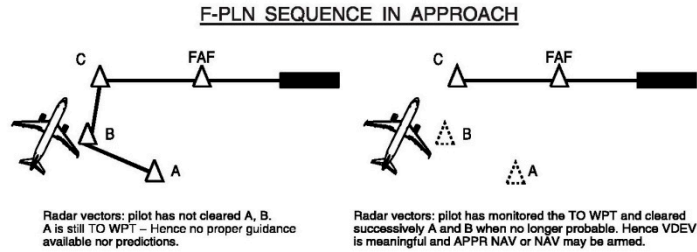
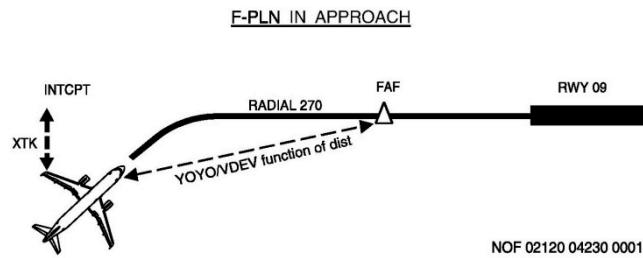

Figure 2-3: Airbus lateral intercept FMS path (all types)

Airbus aircraft may come with or without a capability to create a RADIAL INBOUND towards a selected waypoint. For equipped aircraft, the FCTM provides a technique to create a flight path that intercepts the final approach track prior to the FAF:



When cleared for final approach course interception, the pilot will either

- ⇒ For managed approach
Press APPR p/b on FCU. On the FMA, APP NAV becomes active and FINAL becomes armed. The VDEV or "brick" scale becomes active and represents the vertical deviation, which may include a level segment. The VDEV/brick scale will only be displayed if ILS or LS pb is not pressed. If the ILS or LS pb is pressed by mistake, the V/DEV will flash in amber on the PFD
- ⇒ For selected approach
Select adequate TRK on FCU in order to establish final course tracking with reference to raw data. When established on the final course, the selected track will compensate for drift.

The final approach course interception will be monitored through applicable raw data.

Figure 2-4: Airbus line-up with RADIAL IN option

For aircraft without the RADIAL IN functionality a different technique applies to fly the approach in FINAL APP (managed) mode:

When ATC gives radar vector and clears for final approach course interception, the crew will:

- ⇒ For managed approach
 - Select HDG according to ATC
 - Select APPR p/b on FCU
 - Check on FMA the final approach mode engagement

If the green solid line intercepts the F-PLN active leg (1), this creates an INTERCPT point with final approach axis. APP NAV will engage when intercepting the final approach course.

If the green solid line intercepts the PRE NAV engagement path (2), APP NAV engages when intercepting the final approach course. The PRE NAV engagement path is at least 1 NM and may be longer depending on aircraft speed.

HDG or TRK may be used to smooth the final approach course interception. When close to the final approach course, DIR TO function may be used.

If the green solid line does not intercept the PRE NAV engagement path (3), APP NAV will not engage.

XTK is related to the beam and the ND gives a comprehensive display. Additionally, the VDEV becomes active and represents the vertical deviation, which may include a level segment. The VDEV/brick scale will only be displayed if ILS or LS pb is not pressed. If the ILS or LS pb is pressed by mistake, the V/DEV will flash in amber on the PFD.

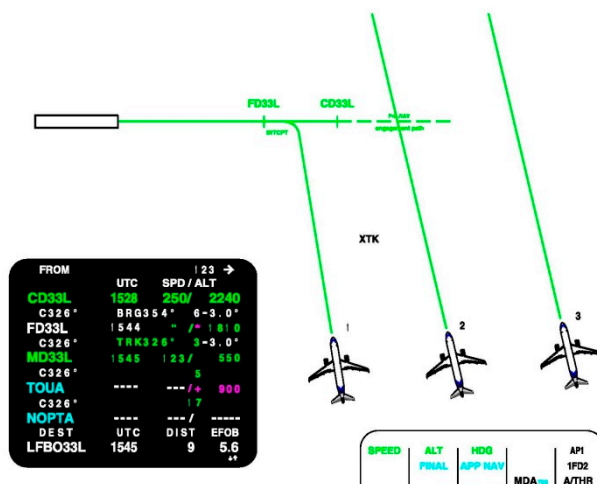

The Airbus SOP identifies different intercept points: between the FAF and IF, just before the IF and well before the IF. Although not specifically prohibited as a Limitation, there are no instructions on how to handle intercepts passed the FAF. The FCOM does mention the following: “It is essential that the crew does not modify the final approach in the MCDU FPLN page”, without explaining possible consequences.

2.2.1.2 Vertical path

For the vertical path the FCOM and FCTM do not indicate a specific altitude where the glidepath must be intercepted. In fact, for RNP AR approaches Airbus indicates that the FINAL APP mode is available when the aircraft intercepts the final approach vertical path to the runway at an altitude above 400 ft AGL.

Airbus types 318-321 and 330/340 fly RNAV approaches using BaroVNAV, the newer types (A350 and A380) offer customer options for SBAS (LPV) and GBAS approach capability.

2.2.1.3 Approach mode

Airbus aircraft can fly the final approach segment in FINAL APP mode, similar to an ILS approach. Use of the autopilot approach capability is available on all Airbus narrow- and wide-body aircraft.

2.2.2 Boeing

As is the case with Airbus products, Boeing Operating Procedures are very similar across the fleet. Unlike Airbus products the installed FMS is not typically a customer option: 737NG aircraft have a GE/Smiths FMS, other products a Honeywell FMS. However, the look-and-feel across the platforms is similar and instructions in FCOM and FCTM are almost identical for 737NG, 777 and 787. [17] [18] [19] [20] [21]

2.2.2.1 Lateral path

The 737 FCOM states the following in the section Normal Procedures, Instrument Approach RNAV (GPS), RNAV (GNSS) or RNP:

“When receiving radar vectors from ATC, intercept course modifications may be used to join the LNAV path at any point on the initial, intermediate or missed approach segments”.

Intercepts on the Final Leg (passed the FAF) are therefore not authorized for 737NG operations. Direct To modifications are not permitted when the fix is the Final Approach Fix (FAF) for the procedure. If a waypoint is added or deleted from the database procedure, the “on approach” logic is partially or completely disabled and VNAV may not be available for the approach or may not provide adequate obstacle clearance.

The 777 and 787 FCOM Normal Procedures section “Instrument Approach RNAV (GPS) or RNAV (GNSS)” states the following Notes:

- If on radar vectors, arm LNAV when approaching or established on an intercept heading to the final approach course.
- 'Direct to' clearances may be accepted to the Intermediate Fix (IF) provided that the resulting track change at the IF does not exceed 45°.
- Direct-To modifications are not permitted when the fix is the Final Approach Fix (FAF) for the procedure.
- No lateral or vertical modifications after IAF, are allowed except to add a cold temperature correction, when appropriate, to the waypoint altitude constraint.

Although not specifically excluded, the FCTM SOPs are written with reference to the Final Approach Fix. No instructions are provided that describe a line-up passed the FAF.

For aircraft with Integrated Approach Navigation (IAN, B787, option on 737NG) another procedure is applicable, an IAN approach can be flown as an ILS as long as the database has a published approach angle and a MAWP at the runway threshold. The above notes are not applicable.

2.2.2.2 Vertical path

When available, VNAV may be used without restrictions on final approach. The database will normally provide a 3° glideslope to cross the threshold at 50 ft. The vertical path is a BaroVNAV path for all Boeing types. Although 3rd party vendors are available for 737NG STC retrofit SBAS packages there are no known 737NG operators in Europe with SBAS capability. The new 737MAX will have SBAS available as OEM option.

The way that the Boeing FMS provides deviations relative to a calculated glide path is explained in the FCTM (all types):

Where there is a glide path (GP) angle coded in the navigation database, the FMC builds the descent path upward and back in the direction of the FAF by starting at the location of the missed approach waypoint (MAP) and its associated altitude constraint. The FMC calculates this path using the coded GP angle, also called the vertical angle. The MAP is normally shown on the LEGS page as a RWxx or MXxx waypoint. In some cases a named waypoint is used as the MAP. A GP angle is coded in the navigation database for nearly all straight-in approach procedures. This GP angle is normally defined by the regulatory authority responsible for the approach procedure and provides a continuous descent at a constant flight path angle for a final approach path that complies with minimum altitudes at intermediate step-down fixes. The typical GP angle is approximately 3.00°, but can vary from 2.75° to 3.77°. The projection of the vertical path upward and back toward the FAF along this coded GP angle stops at the next higher limiting altitude in the vertical profile, (Ed: typically an altitude constraint at the FAF).

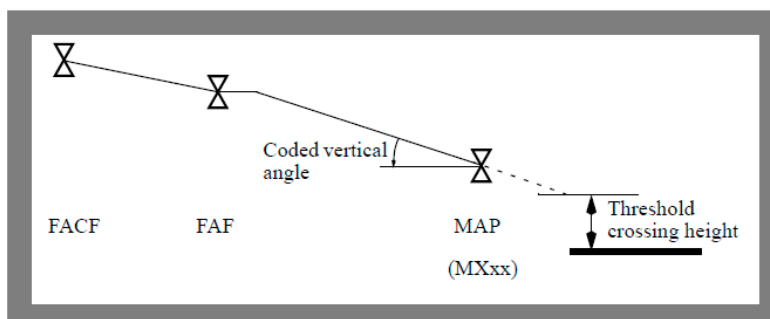

Note: The final approach course fix (FACF) is typically located on the final approach course approximately 7 NM before the FAF. The FAF referred to in the following procedures refers to the charted FAF and is intended to mean the point at which the final approach descent is begun.

For the non-ILS approach procedures with an “At” constraint altitude at the FAF, a short, level segment between the FAF and the final glide path (also called a “fly-off”) may result. For the ILS procedure, the constraint altitude at the FAF is computed to be the crossing altitude of the glide slope.

Figure 2-5: Boeing Vertical Path definition

A vertical path is always available for VNAV operations and can be captured at any point on the approach, including the final approach leg. Although SOPs describe a stable approach with a level segment at the Final Approach Altitude, lower vertical intercepts do not change the vertical navigation capabilities as the VNAV PATH segment is simply captured closer to the runway.

2.2.2.3 Approach mode

Most Boeing aircraft will fly an RNAV approach in LNAV and VNAV autopilot modes. An option for Integrated Approach Navigation (IAN) is available and indeed implemented in several European 737NGs, all 787 aircraft have IAN capability. The FMC transmits IAN deviations to the autopilot and display system. The pilot procedures for IAN are derived from current ILS pilot procedures and are consistent for all approach types: Select the approach on the FMC control display unit, tune the appropriate station, and arm the autopilot approach mode.

2.2.3 Embraer

The Embraer jetline 170/175/190/195 is equipped with a Honeywell FMS, with SBAS as an available option. [22] No survey was performed to determine which aircraft of the Embraer fleet actually have the SBAS option.

2.2.3.1 Lateral path

When selecting an RNAV approach from the database, the pilot is requested to select either a transition or vectors to final. When selecting VECTORS, and subsequently activating the approach, guidance is given to intercept the final approach track to the FAF.

Approximately 2 NM prior to the FAF, angular approach scaling replaces RNP scaling both vertically and laterally. When SBAS is available, the vertical path will revert to SBAS-referenced.

2.2.3.2 Vertical path

A vertical path is always available for VNAV operations and can be captured at any point on the approach, including the final approach leg. Although SOPs describe a stable approach with a level segment at the Final Approach Altitude, lower vertical intercepts do not change the vertical navigation capabilities as the VNAV PATH segment is simply captured closer to the runway.

2.2.3.3 Approach mode

The APP mode is available for ILS approaches only, RNAV approaches must be flown in NAV and VNAV modes. Aircraft with SBAS enabled may fly LPV approaches in the APP mode.

2.2.4 Universal FMS

Universal UNS products are typically found in small and medium sized jet aircraft and turboprop aircraft, although privately owned larger aircraft may have installed a UNS FMS with a Supplemental Type Certificate (STC). Approach capability is available with either BaroVNAV and/or SBAS, depending on installation. The NLR Citation II is also equipped with a Universal UNS1Fw (BaroVNAV, EGNOS/WAAS SBAS) FMS, see section 3. [23] [24]

2.2.4.1 Lateral path

The UNS FMS approach logic identifies two distinct phases:

1. Approach ARMING, and
2. Approach ACTIVATION

When an approach is ARMED, the following happens:

- Scaling is reduced from Enroute to Terminal (1NM) scaling.
- Applicable sensors are tuned (VHF), selected (GPS) or deselected (non-TSO GPS or older position sensors such as LORAN).
- The best available “Level of Service” (BaroVNAV or when appropriate and RAIM sufficient: SBAS) is calculated and selected for the final approach segment. The LoS can be changed by the crew when the approach is ARMED.

Approach arming is available from 50 NM out for manual selection and is automatically selected within 30 NM.

When an approach is activated it is available for autopilot coupling. Activation of the approach occurs automatically when an approach waypoint is sequenced (typically the IF). When an approach is ACTIVATED manually, the following happens:

- All intervening waypoints from the present FR-TO leg to the first approach waypoint will be sequenced, and HSI guidance will be to that waypoint.
- Desired track pointer will be set to the inbound course of the approach.

The FMS discriminates between procedures with a published capture fix (IF) and procedures without a published capture fix. When the aircraft overflies the IF the approach is automatically activated. If there is no IF the FMS will designate a point 2 NM prior to the FAF for approach activation.

When overflying the FAF the following happens:

- Lateral deviation scaling is reduced from Terminal (1NM fixed) to angular Approach scaling (2° splay with a width of 350 ft at the runway threshold).
- When enabled, SBAS will be used to provide vertical deviations.
- Vertical scaling is reduced from a fixed 500 ft (full scale) to angular scaling with a minimum of 150 ft (BaroVNAV) or 45 ft (SBAS).

The FMS Training Manual and Operating Manual both provide instructions for capturing the final approach track prior to the IF, or when no IF is published the FAF. No explanation is offered what can or will happen when the intercept on radar vectors will capture the final approach passed the FAF.

2.2.4.2 Vertical path

Enroute VNAV, available until the FAF, uses barometric altitude inputs. Depending on aircraft equipment, either BaroVNAV and/or SBAS will be available on final approach when passing the FAF.

The FMS manuals accurately describe how the vertical path is constructed. Prior to the FAF the path will always be barometric, passed the FAF it may be SBAS when available and the aircraft is adequately equipped. There are no limitations on where to capture the vertical (BaroVNAV or SBAS) vertical path.

2.2.4.3 Approach mode

For aircraft with approach mode capability, the FMS can provide (angular) deviations for approach mode coupling similar to ILS signals. The approach mode coupling is available after the FMS approach is (manually or automatically) ACTIVATED.

2.2.5 Collins FMS

The Collins FMS-3000 FMS is commonly found on turboprop and smaller jet aircraft such as the King Air, Falcon, Gulfstream, Cessna Citation and Legacy aircraft. Installations with and without SBAS (LPV) capability are available, depending on aircraft options. [25]

2.2.5.1 Lateral path

Selection of an approach requires selection of either an approach transition (TRANS) or VECTORS if radar vectors are anticipated. The FMS Operator's Guide states the following:

Select the VECTORS transition when vectors to final approach are expected. This transition consists of a course-to-fix leg in the flight plan leading to the final approach course toward the Final Approach Fix (FAF) or toward the Final Approach Course Fix (FACF) fix if present. With this course-to-fix leg established, follow radar vectors manually with the autopilot, or with the flight director. When the aircraft is properly positioned and cleared for the approach, intercept the course-to-fix leg leading to final approach, either manually or using the flight control system.

This means that, when selecting the approach, the active leg will be an inbound course to the FACF (=IF).

In addition, to sequence to the final approach segment of the approach special conditions apply for overflying the FAF:

To prevent the FAF from sequencing prematurely, regardless of the aircraft position, special waypoint passage criteria applies to the FAF. At 2.0 NM radial distance from the FAF, the criteria that follow must be true:

- The aircraft must have less than 1.6 NM cross track deviation.

- The magnitude of intercept (track angle minus outbound course from the FAF) must be less than 90 degrees.
- The aircraft altitude must be less than 3000 feet above the FAF altitude constraint.
- The FAF must be the TO waypoint or next waypoint after the TO waypoint.

This means that the aircraft can bypass the FAF for a short line-up, but only under specific XTE and VDEV constraints. In principle the FAF has to be overflowed.

2.2.5.2 Vertical path

As with all other installations, the Collins FMS-3000 calculates and displays VNAV information based on available aircraft sensors (BaroVNAV and/or SBAS). Depending on installation, VNAV is either advisory or available for autopilot coupling. There are no specific equipment-related altitude constraints for the use of VNAV: the approach can be vertically captured anywhere on the approach, including passed the FAF.

2.2.5.3 Approach mode

The earlier implementations of the Collins-3000 FMS are not compliant with AC20-26 or 27, therefore do not offer RNAV approach capability. The FMS will provide lateral and vertical deviations, but these are advisory only. Recent installations on Challenger, Hawker, Falcon and Gulfstream aircraft offer full LPV capability and autopilot approach mode coupling.

2.2.6 Garmin

Garmin integrated solutions (G1000) are a popular choice for small single- or dual engine aircraft including Beechcraft, Cessna (all piston and Mustang jet aircraft), Diamond, Cirrus Design, Mooney, Piper and Quest Aircraft, with retrofit packages available for the C90 KingAir. Non-integrated solutions (G400 series) are available on a wide range of older small aircraft. Both the G1000 as well as the G430w offer SBAS capability, some aircraft may be equipped with an Air Data Computer as part of the system architecture, providing BaroVNAV (enroute and approach) capability. [26] [27] [28]

2.2.6.1 Lateral path

Garmin distinguished between “loading” an approach from the database and “activating” an approach. When “activating” the approach the pilot is offered the option to do that via a published procedure, or via “VECTORS”. When selecting VECTORS the following happens:

- The FAF will become the active waypoint, and guidance is provided to establish on the final inbound course.
- Lateral scaling reduces from 2NM (enroute) to 1NM (terminal).
- 2NM prior to overflying the FAF the approach mode becomes active and lateral scaling becomes angular with a 2° splay.

The G1000 allows the pilot to manually select any approach, departure, or arrival leg as the active leg of the flight plan. For automatic sequencing to occur, the aircraft must also cross the “bisector” of the turn being navigated.

2.2.6.2 Vertical path

Although again the final approach segment can in principle be intercepted at any point in the approach, Garmin systems with TAWS enabled do provide a warning when attempting to intercept below the published FAA on an SBAS approach:

When the Final Approach Fix (FAF) is the active waypoint in a GPS SBAS approach using vertical guidance, a Low Altitude Annunciation may appear if the current aircraft altitude is at least 164 feet below the prescribed altitude at the FAF. A black-on-yellow LOW ALT annunciation appears to the top left of the Altimeter, flashing for several seconds, then remaining displayed until the condition is resolved.

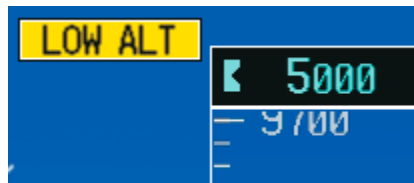

2.2.6.3 Approach mode

Garmin products are found in a wide range of aircraft with differing capabilities. An autopilot with approach mode may be coupled to the Garmin VDEV, allowing for approach mode steering.

2.2.7 Overview

The following table provides a tabulated overview of the review of Operating Manuals for the different aircraft types and FMS capabilities:

FMS/aircraft type	Operational procedure	FPL protected	Latest vertical capture	Vertical guidance
Airbus	Intercept before FAF	FAF-THR	400 ft AGL	BaroVNAV
Boeing	Intercept before FAF	FAF-THR	None	BaroVNAV
Embraer	Intercept before FAF	FAF-THR	None	BaroVNAV/SBAS
Universal FMS	Intercept before FAF	IF-THR	None	BaroVNAV/SBAS
Collins FMS	Has to overfly the FAF	FAF-THR	None	BaroVNAV/SBAS
Garmin Integrated Flight Deck	Intercept before FAF	FAF-THR	FAA	SBAS

2.3 Aircraft Equipment

2.3.1 Aircraft Navigation Guidance and Control functions

Aircraft functions associated with navigation in general and with approach operations more specifically may be generalized to form a closed loop controller: manipulating the vehicle (guidance and control of the aircraft), to manoeuvre from its current position (part of the aircraft current state) to achieve a future position (control reference state – as a function of time), following a plan.

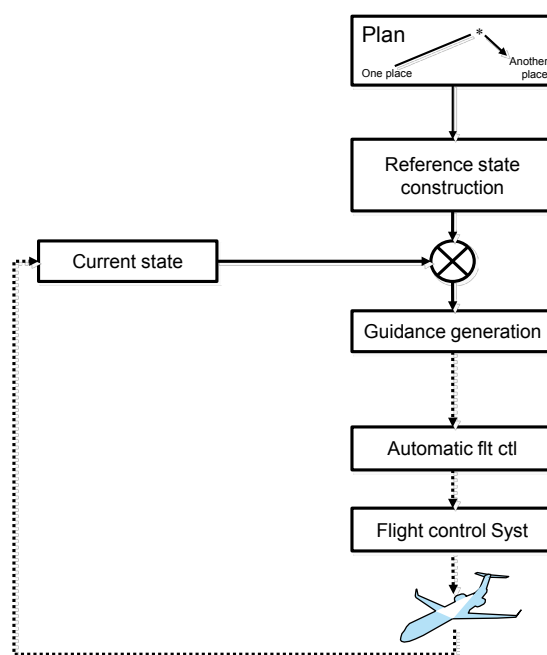

Figure 2-6: Aircraft generalized navigation function

Figure 2-6 illustrates the concept, showing the ‘plan’ at the top, which is evolved into the control reference state, driving the control functions and thereby influencing the aircraft current state, thus closing the loop around the reference trajectory.

A more detailed depiction is in Figure 2-7 showing the ‘layered’ structure, with the position loop at the top (the ‘outermost loop’) and the flight control system loop at the bottom (operating the flight control surfaces), also referred to as the ‘innermost loop’.

In addition, the generic allocation of main functions is shown, with the flight management computer (FMC) part of the flight management system (FMS) at the top and the flight control system (FCS) at the bottom.

The FMC performs the flight planning function and derives the reference trajectory by performing a ‘forward simulation’ covering the planned origin-destination including points underway (as applicable), considering aircraft performance and engine data, the navigation data base, any inserted constraints and options, aircraft economy cost index and other pertinent parameters. The result is a description of the path the aircraft is expected to follow as a function of time in the lateral and vertical sense; this path is subject to re-calculation on the basis revised assumptions (e.g. wind speeds aloft), revised constraints (e.g. a required time of arrival over a certain position), or changing aircraft properties and performance (e.g. changing mass over the duration of the flight, conditions like an engine out).

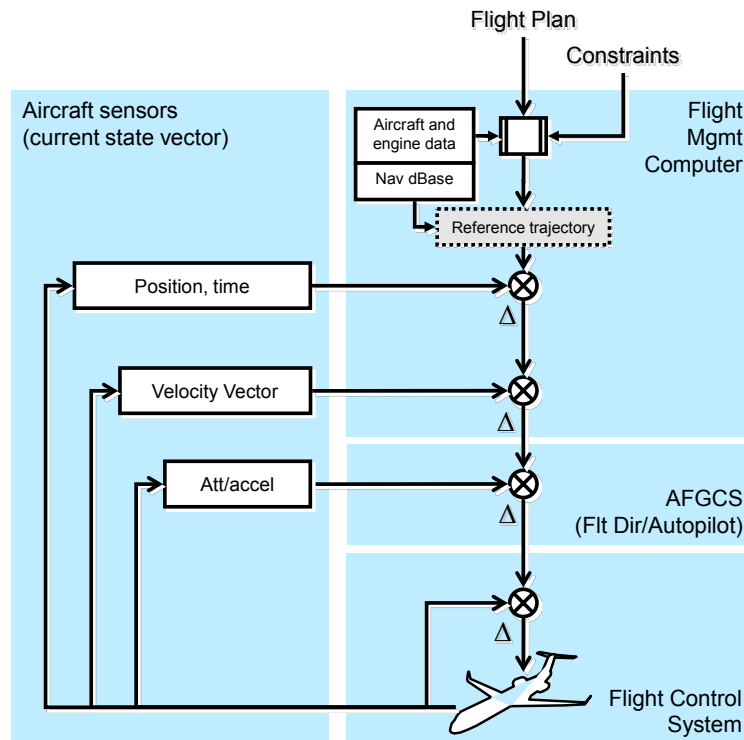

Figure 2-7: Aircraft navigation, guidance and control functions

For a given instantiation of the reference trajectory, the aircraft present position is used to compute the control error at the velocity vector level. In turn, the present value of the velocity vector is used to compute the control error at the attitude and accelerations level, i.e. commanded roll/pitch body angle, as well as angular/longitudinal rates. This control error is delivered to the automatic flight guidance and control system (AFGCS) which, in turn, computes flight control surface demands to the FCS, on the basis of current aircraft attitude and accelerations. The FCS loops are closed by flight control surface angles, including more or less sophisticated ‘autonomous’ dampening, stabilization and envelope limiting functions, as in fly by wire (FBW) implementations. The flight control system operates on the aircraft, thus manipulating the aircraft current state and causing the higher level control loops to close, ultimately at the position level thus closing the loop around the reference trajectory. The Reference trajectory is constructed and laid out taking into account of not only aircraft/engine performance, but also attitude/angular rate limitations and aircraft properties (as they will exist for several reasons and causes), elements from the navigation database and any governing options and constraints.

2.3.2 Approach operations

2.3.2.1 General

An approach operation is a generic navigation operation but, rather than proceeding to an in-flight waypoint, it is aimed at the runway threshold or typically a point before that, suitably selected for landing to be undertaken and completed – either manually or automatically and subject to decision associated with verifying acceptable initial

conditions. If these conditions cannot be met, a missed approach is undertaken, comprising a 'go-around' manoeuvre followed by resumption of navigation to the missed approach procedure.

For this reason, an approach typically comprises the following key elements, ref [29]. Figure 2-8 illustrates:

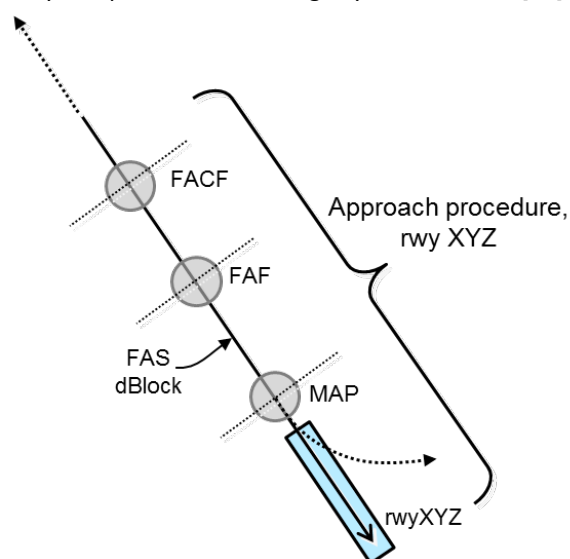

Figure 2-8: Approach - key elements

- RwyXYZ is the runway to which the approach for landing is being made; an approach procedure into this runway will be referred to as such.
- Final Approach Course Fix (FACF, short CF) is the initial point of the approach procedure, spaced away from the final approach fix by up to 8 NM, but no less than 2 NM.
- Final Approach Fix (FAF, short FF) or also Final Approach Point (FAP) is the point from where the final approach to the runway commences which, in the case of an ILS precision approach, would typically coincide with the location of the Outer Marker (OM).
- Missed Approach Point (MAP) is the point on the approach path from which the missed approach procedure begins, up to the missed approach holding fix. It is not to say that a particular flight will start a missed approach from the MAP should it be needed; rather does it mean that a coded missed approach procedure originates at the MAP – wherever the missed approach operation is started from in the actual operation.

2.3.2.2 Final Approach Segment - FAS

One key element of an RNAV approach is the final approach segment (FAS) data block. The FAS dBlock comprises the approach path descriptor of the approach procedure, basically between the final approach fix (FAF) and the runway threshold, as it was designed by the designated national air navigation service provider.

This procedure design is "coded" by one of a few aviation charting companies (e.g. Jeppesen, Lido) into a generic format suitable for conversion by the avionics manufacturer into an aircraft avionics-compatible format. The resulting data is stored in a 'compartment' of the aircraft FMS database, with subsets protected by a cyclic redundancy check (CRC) function required to maintain integrity of the data suitable for application in approach to land operations (Figure 2-9).

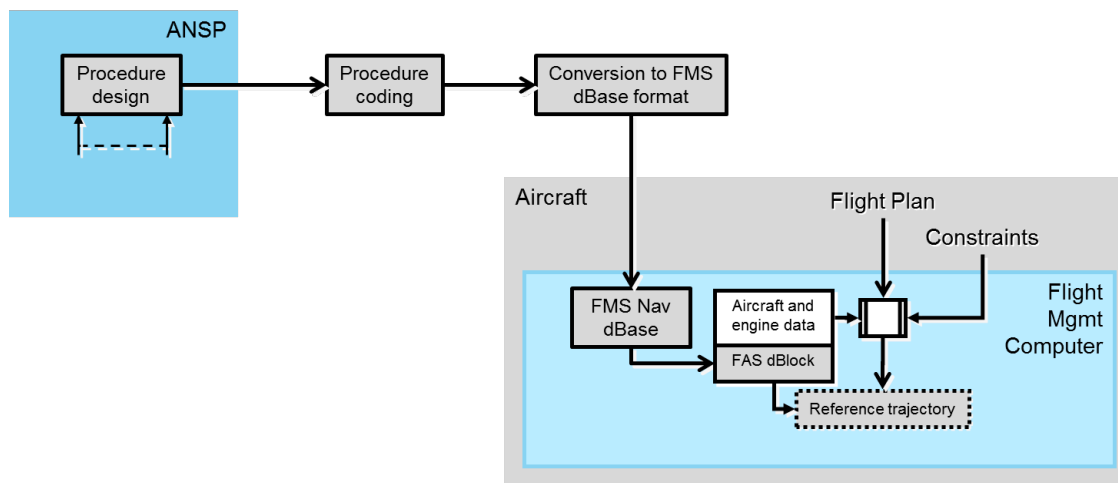

Figure 2-9: Approach procedure, FAS dBlock

2.3.2.3 Approach classification

Approach operations may be classified as per ICAO Annex 6 ('Operation of Aircraft', ref [30])

1. Non-precision approach (NPA) procedure
 - a. An instrument approach procedure designed for 2D instrument approach operations Type A
2. Approach procedure with vertical guidance (APV)
 - a. A performance-based navigation (PBN) instrument approach procedure designed for 3D instrument approach operations Type A
3. Precision approach (PA) procedure
 - a. An instrument approach procedure based on navigation systems (ILS, MLS, GLS and SBAS CAT I) designed for 3D instrument approach operations Type A or B.

This being operational classification, technically, as far as the aircraft installation is concerned, only two main aircraft system arrangements exist associated with approach to landing:

1. An 'extended' area navigation function
2. An installation receiving deviation inputs from a glidepath radio arrangement relative to the runway.

The main principal difference between these two installations is in the navigation principle:

1. The (extended) area navigation system generates and contains the reference trajectory as part of the aircraft system, while the position estimate needed to navigate towards this reference is generated by the aircraft system as well. "Extended" in this context refers to the approach application, where the navigation process is extended all the way to a minimum descent altitude, or decision point, for landing.
2. In the second category, the reference trajectory (glidepath) is comprised in a set of external radio signals without being explicitly defined, from which the aircraft ILS or MLS² receiver measures deviation in the lateral and vertical sense, basically without requiring a present position estimate either³. These deviations are converted by the AFGCS into flight control system roll and pitch commands. We may see that this latter installation is not burdened by accuracy/resolution, continuity and integrity requirements on the reference trajectory and on

² Instrument Landing System – ILS, or Microwave Landing System – MLS

³ A third "XLS" receiver class is the GNSS based landing system (GLS); GLS also delivers glidepath deviation to the AFGS, in format compatible with ILS, thus allowing AFGCS performance and sub-mode switching like in the case of ILS or MLS ("ILS look alike"). GLS is not treated in this report for reason of scope limitation

ownership position, thus considerably reducing the contributing factors to function critical faults and failures and enabling operation down to very low minimums and to no-decision height type operations.

2.3.2.4 RNAV approach

Figure 2-10 shows the general navigation guidance and control arrangement discussed above, but more specific to “extended” RNAV (approach) operation up to and including Localizer Precision with Vertical approach (LPV) as the maximum available level of service.⁴

The functions outlined in black perform the RNAV approach operation.

As discussed, in principle the RNAV approach is treated as the ‘extension’ of the ordinary flight plan, by calling up the approach procedure from the data base and appending it to the flight plan. The FMC then treats it in the same way as any other flight plan element and derives control error at the level of the attitude/acceleration loop, delivering roll and pitch steering to the AFGCS.

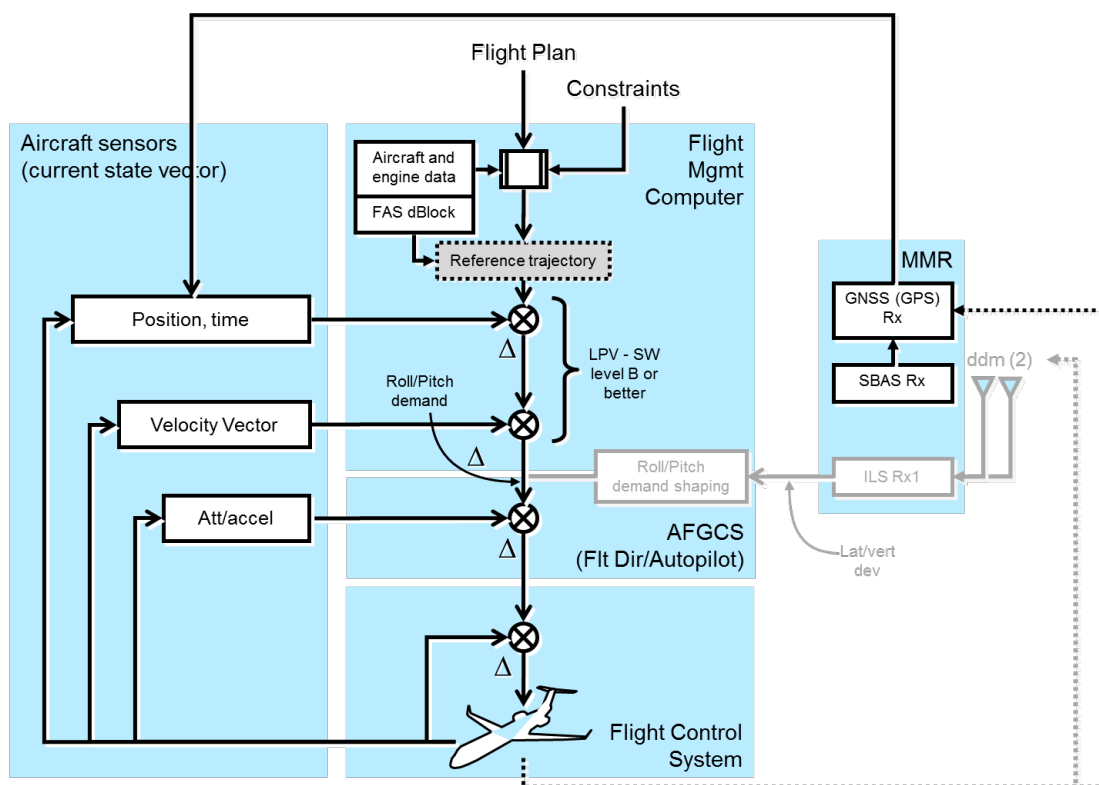

Figure 2-10: Aircraft arrangement, RNAV incl. RNAV approach

There is number of implications to this arrangement, primarily that the AFGCS does not “treat” the commanded body angles (apart from any possible downstream attitude/acceleration protection or other envelope limitations). It means that the FMS computes all terms required to fly the interception and the subsequent approach procedure, down to the point of disconnecting from the approach guidance at approach minimums. Any approach interception and capture criteria and control functions go by the rules the FMS applies in developing guidance, including feed-forward terms (turn anticipation), turn radius, track keeping, wind drift correction, reference trajectory leg sequencing, etc.

⁴ The MMR is part of a typical air transport aircraft arrangement, business aircraft typically have dedicated ILS and GNSS/SBAS receivers

There are several types of RNAV approach operation; they all have in common that the FMS navigates to a reference trajectory designed to approach a runway; the difference being in the way this reference is defined and the way the present position is estimated.

In each case, lateral navigation is random area navigation (RNAV) from one set of coordinates to the next, while the vertical path component is described in one of two ways:

1. a sequence of barometric altitudes each to specific geographic coordinates
2. a geometrically defined path defined in polar coordinates, i.e. a point and an angle as in the case of LPV FAS data block.

Because of improvements in the way the reference trajectory may be defined and ‘contained’ (in terms of data integrity) and in the way the present position may be estimated and assured, an increase in service level has become available. The most demanding RNAV approach service level is Localizer Performance with Vertical (LPV), comprising integrity in both the reference path and in the present position estimate. The function allows approaching the landing runway to minimums as low as 200’ (comparable with ILS precision approach category-I)

In addition to the data aspect, the computational functions associated with these operations must be designed to achieve an elevated level of trustworthiness, demanding hardware and software reliability consistent with the hazard classification of the operation (Table 2-1 and Table 2-2 illustrate)

Table 2-1: Approach Hazard Classification (FAA AC 20-138C)

	Advisory Vertical Guidance	Enroute/Terminal Area/Nonprecision Approach (LNAV or RNP 0.3)	Nonprecision Approach with Vertical Guidance (LNAV/VNAV)	LP/LPV Approach	GNSS Precision Approach (Cat. I)
Loss of Navigation	No Effect	Major	Major	Major	Major
Misleading Information	Minor	Major	Major	Hazardous	Hazardous

Table 8. Typical Hazard Classifications

Following CS 23/25 .1309, the [sub-] systems contributing to the function must meet corresponding reliability requirements, summarized in Table 2-2, showing the required HW and SW design assurance levels as they flow down from the potential effect of misleading information in LPV.

Table 2-2: System design assurance (FAA AC20-165)

Figure 9. System Design Assurance Table

SDA Value	Supported Failure Condition ^{Note 2}	Probability of Failure causing transmission of False or Misleading Information ^{Note 3,4}	Software & Hardware Design Assurance Level ^{Note 1,3}
3	Hazardous	$\leq 1 \times 10^{-7}$ Per Hour	B
2	Major	$\leq 1 \times 10^{-5}$ Per Hour	C
1	Minor	$\leq 1 \times 10^{-3}$ Per Hour	D
0	Unknown/ No safety effect	$> 1 \times 10^{-3}$ Per Hour or Unknown	N/A

Note 1: Software design assurance per RTCA/DO-178B or equivalent. Airborne electronic hardware design assurance per RTCA/DO-254 or equivalent.

Note 2: Supported failure classification defined in AC 25.1309-1, AC 23.1309-1, and AC 29-2.

2.3.2.5 ILS, MLS Precision approach

The second principal aircraft approach system installation, per para 2.3.2.3, sub 2, comprises Instrument Landing System (ILS), or Microwave Landing System (MLS) operation.

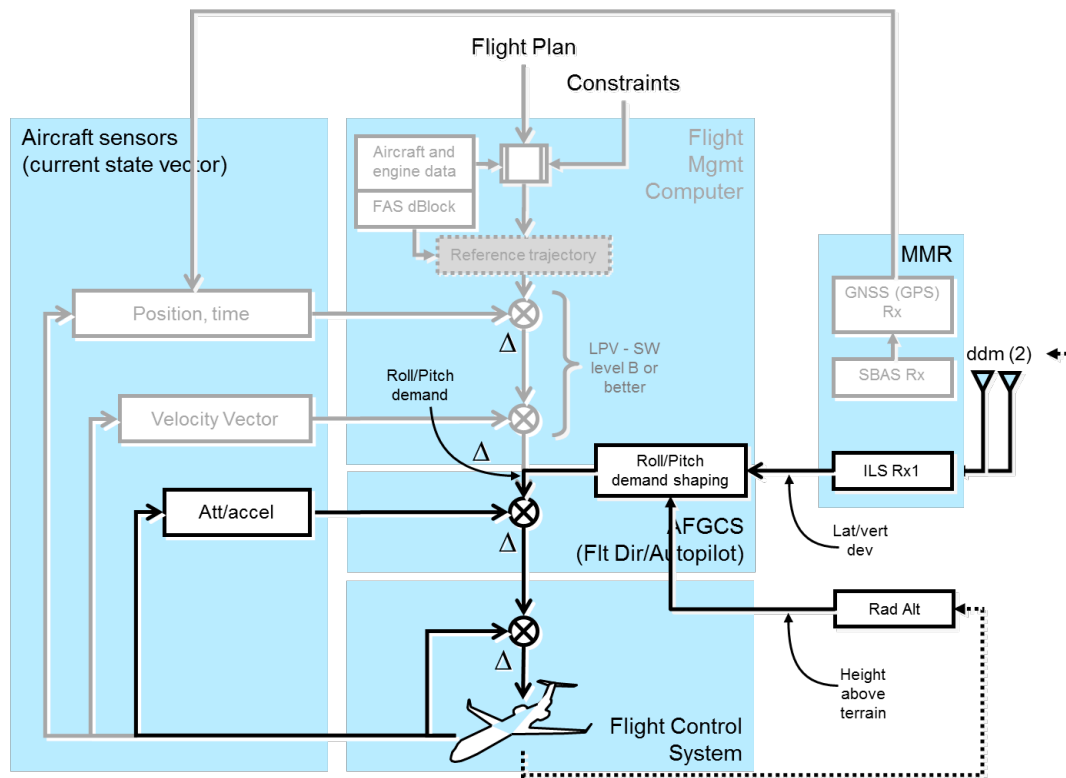

Figure 2-11: Aircraft arrangement, precision approach

This installation enables precision approach ranging from category I to category III all-weather operations (AWO), involving not only delivering the aircraft to the point from where landing will be initiated, but also performing the landing automatically, given that in the critical cat III case there are no [visible] cues for the human pilots to judge trustworthiness of the aircraft position and velocity vector relative to the touchdown point and the runway centreline. An automatic landing under such conditions is critical to the safety of the persons on board of the aircraft, so that the level of reliance placed on the function and all of its sub-functions is extremely high; this requires system complexity to be minimized in order to achieve such levels of reliability both in terms of precision, reliability and integrity (fault containment)

Figure 2-11 shows the generalized aircraft arrangement with the functions outlined in black performing the precision approach and, ultimately, automatic landing operation.

Input to the AFGCS is lateral and vertical deviation from the ILS receivers⁵. There is no explicit path reference on board of the aircraft, only path deviations are measured; likewise, the present position estimate and position-level error generation are not required, thus greatly simplifying the construct and enabling elevated levels of reliability and integrity to be achieved. Deviations indicate control error at the level of the aircraft velocity vector, so that the AFGCS in this case derives roll and pitch command from deviation. This [AFGCS] function is at work only in the case of precision approach operation while also in essence controlling [ILS] interception and capture mode logics⁶.

⁵ For simplicity, one ILS receiver is shown; in practical cat-III AWO autoland installations up to 3 are installed to enable sensor voting

⁶ In all other cases, the FMS delivers roll and pitch command to the AFGCS and performs all logical sequencing

Another key input is radio altitude. ILS displacement gain increases inversely with distance to the runway threshold, while the ILS glideslope becomes anomalous from approximately 100' above the threshold onwards and radio altitude⁷ is used to estimate these functions and to enable sub-mode switching associated with control-law scheduling, all the way to landing the aircraft (main landing gear and nose landing gear) considering prevailing environmental conditions (wind, gust, temperature, humidity).

In lieu of ILS receivers, MLS receivers may be installed, all other functions remaining more or less identical. MLS has distinct advantages over ILS in that the airborne system comprises fewer parts (a single RF front end for both lateral and vertical deviation), while the installation and operation overall is much less prone to interference than is ILS. GLS is a relatively complex function involving many sub-functions including the on-board replication of a reference path towards the runway, quite analogous to the FAS dBlock in LPV but at a level of dependability corresponding with cat III operational requirements. Similarly, a form of RNAV must be performed to derive lateral and vertical deviation, but again at a much increased level of dependability. As a result of the range of GLS sub-functions and dependencies and the dependability requirements flowing down from the cat III performance requirement, the present state of art in GLS is limited to a cat-I approach service level.

In today's system architectures, the ILS receiver and potentially MLS and or GLS functions, are installed by way of a multimode approach receiver (MMR). To enable future GLS, the GNSS receiver has become part of the MMR so that, also for any other position determination purpose, this [GNSS] information is obtained from the MMR even if GLS is not installed.

2.3.2.6 Approach operation mode switching

In general, FMS coupling to the AFGCS is by way of the AFGCS LNAV and VNAV modes, for lateral and vertical guidance respectively (Figure 2-10).

Precision approach operations are performed by way of the AFGCS APPR mode, with ILS (MLS) as the source of navigation information (Figure 2-11).

RNAV LPV operation is a combined area navigation-approach function, with the FCS operated in the APPR mode in order to have guidance to the FMS generated vertical glide path (combined logic using FMS as the nav source, RNAV LPV active and APPR as the FCS mode).

The terms LNAV and VNAV are used interchangeably to indicate the mode of operation for AFGCS coupling to FMS guidance and the process of performing lateral (vertical) navigation (see Figure 2-12). Aircraft operating and training manual typically refer to LNAV (VNAV) as the AFGCS mode of operation while standards, equipment characteristics and authoritative documents many times refer to it as the type of navigation.

⁷ Only one radio altimeter is illustrated, in practical installations up to 3 radio altimeters are installed to achieve the required level of dependability

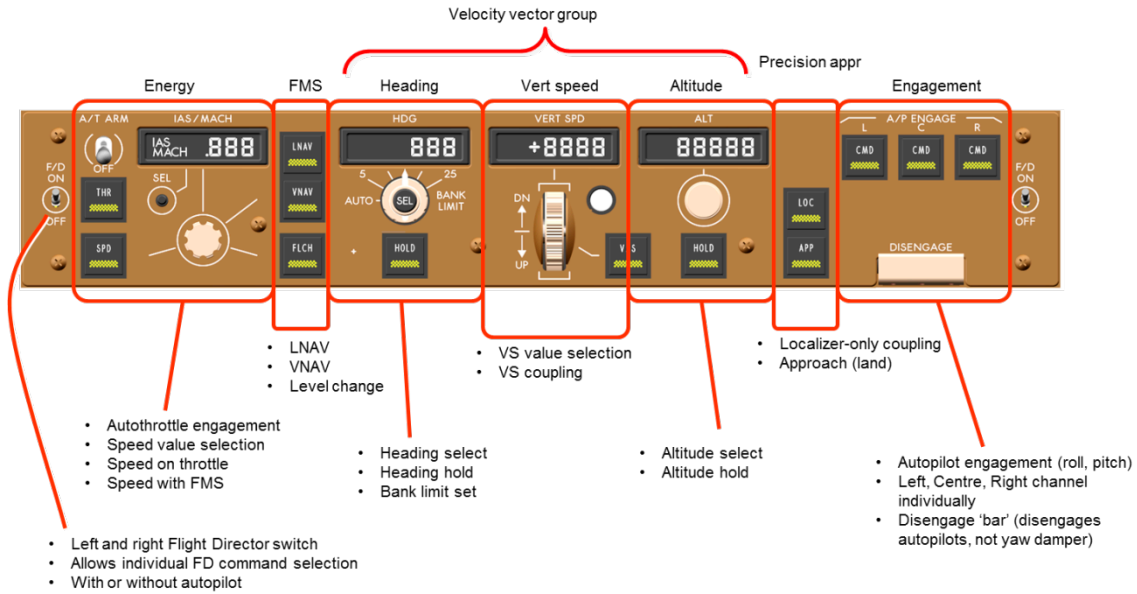

Figure 2-12: Example AFGCS flight mode panel (Boeing B757, -767, -747)

2.3.3 Reference trajectory construction

The FMS constructs the reference trajectory following the flight plan, while recognizing the aircraft aerodynamic properties, engine characteristics, generic aircraft dynamic control properties, as well as economy and optimization functions. The result is a path definition in the horizontal, vertical and time dimension, which the aircraft is to follow in order to respect all of the above.

The Reference trajectory is characterized by trajectory change points (TCP) and other attributes needed to describe straight segments, turns, climbs/descents, etc. This information is coded following a standardized protocol; examples are shown in Figure 2-13 and Figure 2-14. [31]

In the example, the “Named Waypoint” is the waypoint called out in the flight plan, in this case a Fly-By waypoint including altitude constraints. The FMS generates a range of TCPs “around” this waypoint needed to construct straights, turns, connections, vertical path elements, etc., so as to unambiguously define the complete path consistent with aircraft capability and economy requirements.

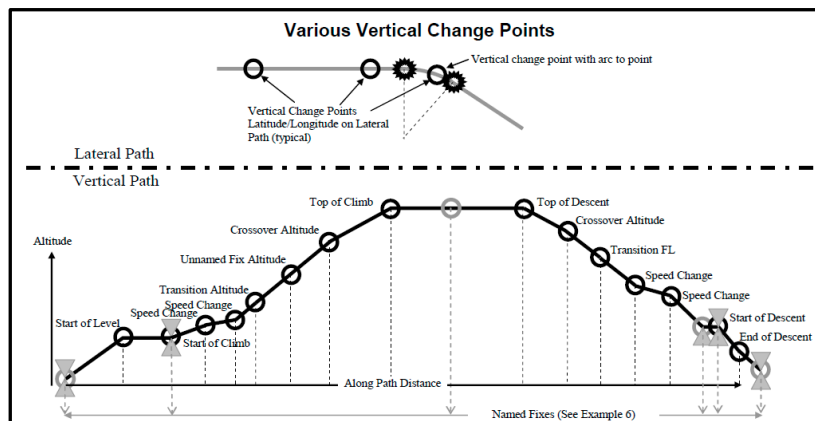

Figure 2-13: Reference Trajectory example (1/2)

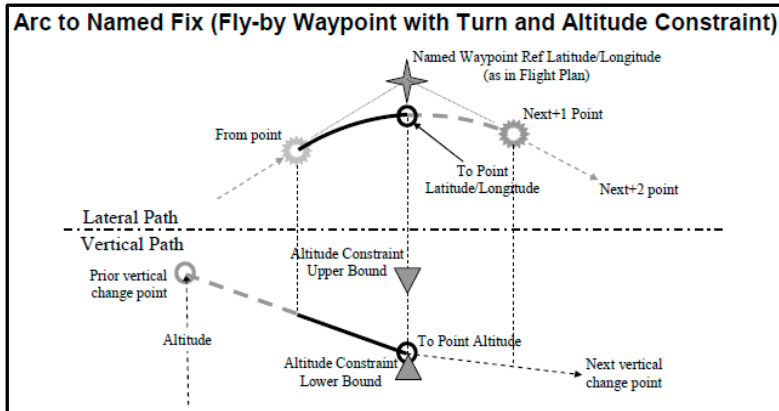

Figure 2-14: Reference Trajectory example (2/2)

In this way the FMS constructs the entire reference path from departure/present position principally up until the destination.

To maneuver from one point to the next, the FMS performs flight plan 'leg sequencing'; the criteria for sequencing are generally as follows:

- Straight segments
 - The FMS sequences from the current 'To' point to the next when the aircraft crosses any point abeam of the waypoint (passing "overhead" being one).
 - Example in Figure 2-15: Wpt A, C, D, FAF and MAP.
- In turns
 - When proceeding through a turn, the leg would sequence as the aircraft crosses the bisector of the turn.
 - Example in Figure 2-15: Wpt B, FAF.

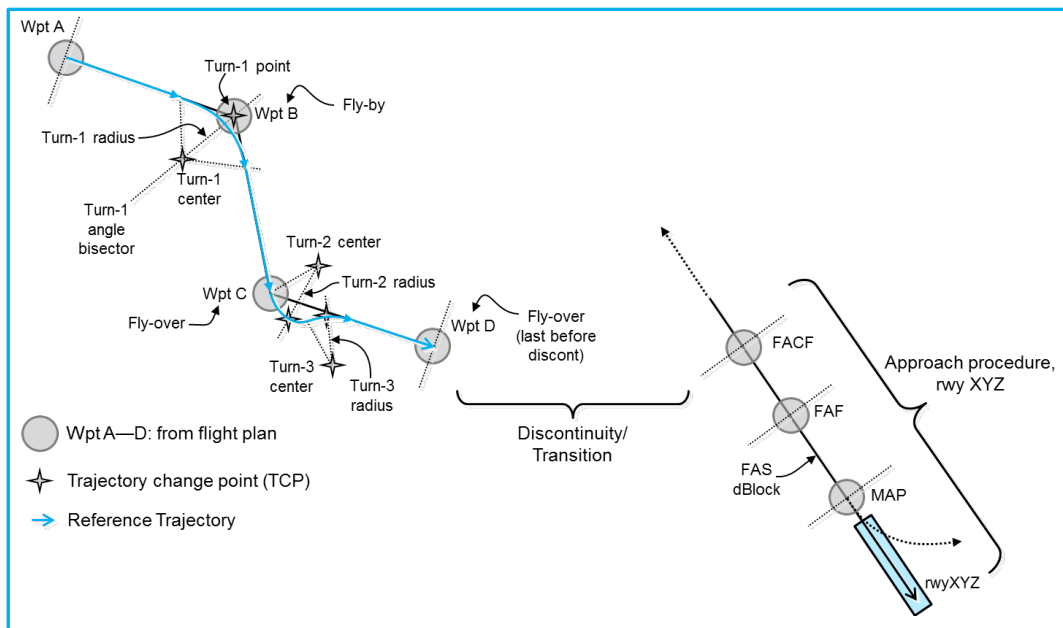

Figure 2-15: Flight plan and approach procedure

2.3.4 FMS RNAV approach ‘procedure’⁸

The approach procedure to be followed at the destination airport depends on winds at the time of arrival, as well as constraints from an air traffic control perspective.

For this reason, the approach to be flown will usually⁹ be selected as part of the arrival planning. Arrival planning comprises selection of the desired runway from the destination airport set. This set may be limited to the [two] runway ends of a single runway up to [two runway ends each of] several runways, like in the case of Amsterdam Airport Schiphol. For each runway end, typically a number of approach procedures may exist, such as an NDB non-precision procedure, an ILS cat I-II-III procedure, an LPV procedure, etc. Thus, the number of possible procedures into a given airport may be numerous and each one will exist in the FMS data base for the runway in question¹⁰, so that it may be selected and called up to become appended to the flight plan.

Because of the above, by default, the flight plan will be ‘discontinuous’ from the final waypoint of the en-route or standard arrival (STAR) segment (as applicable) onwards. Such discontinuity must be removed (resolved) between this final waypoint and the approach procedure in question, in order to connect the two, see Figure 2-15.

To append the approach, the discontinuity may be removed by one of the following:

- Selecting and activating a ‘Transition’ [29]
 - Transitions to the final approach exist in FMS data base if they were designed in association with the approach procedure.
 - Typically, transitions comprise the Initial Approach Fix (IAF, or short AF) as well as additional sequences such as a holding, ultimately towards the Final Approach Course Fix (FACF) or directly to the FAF (if for the approach in question an FACF is not coded).
- Vectors
 - If a Transition to the approach is not selected, the default is ‘Vectors’ in which heading and altitude selections are used, typically in response to air traffic control (ATC) to direct the aircraft towards the final approach path.
 - The FMS flight plan continues to sequence as vectors are being executed. Assuming the discontinuity to the approach was resolved, it means that the waypoints towards the FACF or FAF will sequence as the aircraft settles on the approach path.
 - AFGCS hdg/alt/speed, with Flight plan set up for the desired approach.
- Direct to
 - A direct-to a waypoint of the approach procedure (for example the FACF) may be selected in which case the aircraft will proceed from present position directly to that selected position.

2.3.5 FMS RNAV approach enabling and capturing conditions

When the FMS sequences from the en route segment to the approach segment and the [great circle] distance to the airport reference point (ARP) falls below 31 NM, the system transitions from en-route cross track deviation displacement gain (± 10 NM, full scale) to ‘terminal’ displacement gain (± 1.0 NM), while vertical deviation scaling adjusts to ± 500 feet, full scale.

⁸ The word ‘procedure’ is used interchangeably between the ‘flight path/sequence of waypoints and constraints’ as designed by the state/national air navigation service provider, uploaded into the FMS navigation data base and the list of steps the flight crew are to take in setting up an aircraft, or [navigation] system configuration

⁹ In some cases the runway in use may be known earlier than by the time arrival planning is performed, for example in case of a very short flight time

¹⁰ Airport approach procedures will be in FMS data base assuming the procedures were published and the FMS data base is current

As the aircraft is being maneuvered onto the approach path, in ways described in para 2.3.4 above, the approach will be enabled if:

- the FAF is the 'from' waypoint
- and the distance to the FAF is 2 NM
- and the intercept angle to the final approach course is ≤ 45 degrees¹¹.

Figure 2-16 illustrates.

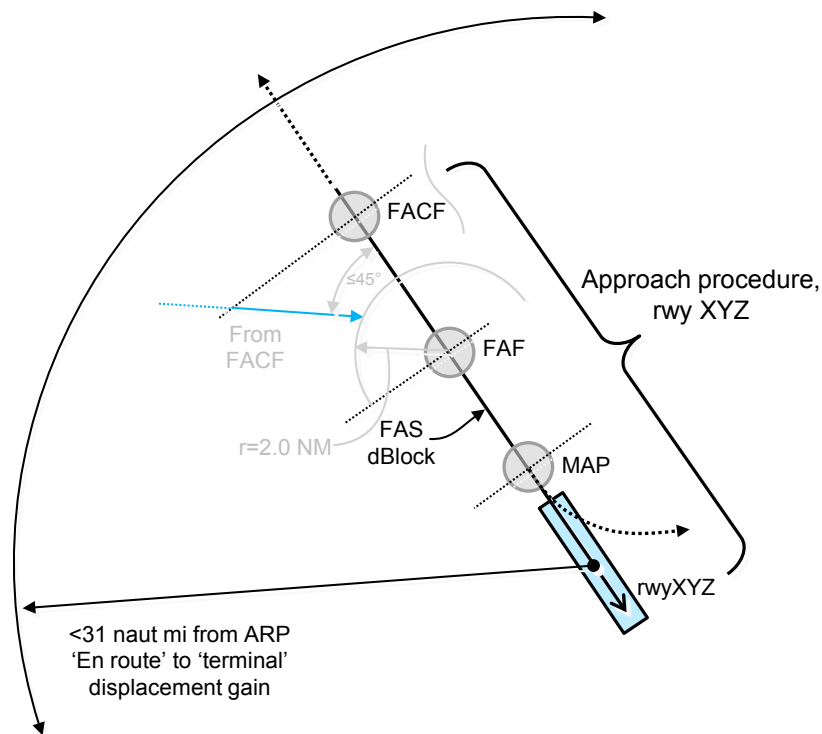

Figure 2-16: 'Approach' enabling conditions

This set of conditions is to assure that the aircraft path is towards the FAF while converging onto the centerline including allowance for aircraft turn control dynamics. If these conditions cannot be met, the flight plan will not sequence so that the approach path will not become enabled.

FMS vertical guidance is based on Baro-VNAV¹² until SBAS VNAV is used for LPV or L/V approach. Since Baro-VNAV is affected by current atmospheric conditions while SBAS VNAV is not, the two glidepaths will not always coincide.

Once proceeding on the approach and the FAF waypoint sequences, the system automatically transitions to approach deviation sensitivity (± 0.3 NM in case of general RNAV approach, or angular-converging scaling in the case of RNAV LPV approach or angular displacement gains if LPV).

¹¹ The 45 deg condition is to comply with regulations associated with obstacle clearance when performing approach operations

¹² There is no geometrically defined path for the part of the approach prior to LPV path interception, therefore barometric altitude reference path until that point

2.3.6 FAF sequencing criteria

In order to achieve orderly approach trajectory interception and tracking there are special criteria for the FAF to sequence, i.e. for the approach path between FAF and MAP to become active, in deviation from standard waypoint sequencing criteria (passing abeam, or passing the turn bisector).

The following FAF sequencing criteria apply:

- The FAF must be the TO waypoint or the next waypoint after the present TO waypoint, thus assuring that the aircraft reference trajectory is towards the FAF.
- At 2 NM before the FAF, the aircraft must have less than 1.6 NM cross track deviation, assuring a position close to the centerline.
- The track angle error¹³ must be less than 90 degrees, assuring that the aircraft is approaching the FAF in a direction towards the runway.
- The aircraft altitude must be less than 3000 feet above the FAF altitude constraint.
- Inside those logical conditions, the aircraft must pass the FAF in order to sequence, making the MAP the TO waypoint.

Figure 2-17 illustrates.

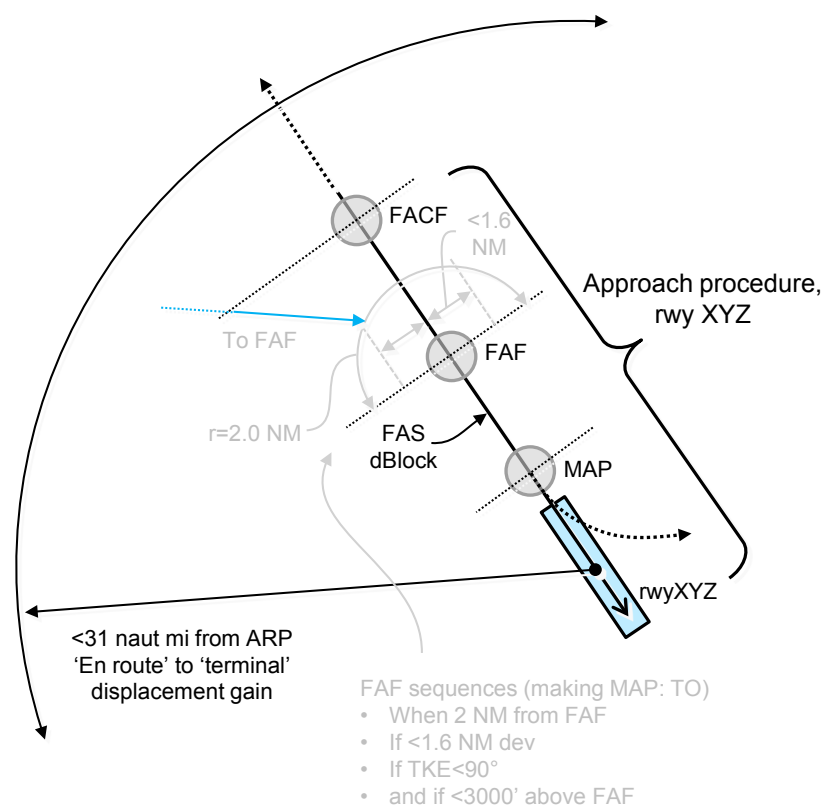

Figure 2-17: FAF special sequencing conditions

¹³ Absolute value of aircraft track angle minus the centerline course angle

3 Analysis

3.1 Findings from Approvals/Certification & Regulations

The review of the operational criteria in section 2.1 show:

- It is not allowed to modify the lateral and vertical definition of the flight path between FAF and Missed Approach Point.
- A direct to the FAF is not acceptable.
- Modifying the procedure to intercept the final approach track prior to the FAF is acceptable.
- A direct to the IF is allowed, provided that the aircraft is established on the final approach track at least 2 NM before the FAF (EASA) or provided that the resulting track change at the IF does not exceed 45 degrees.
- The final approach trajectory must be intercepted no later than the FAF, in order to be correctly established on the final approach track before starting the descent (to ensure terrain and obstacle clearance).

The review of the airworthiness criteria in section 2.1 show:

- For LPV, it is required to provide cross-track deviation indications relative to the extended Final Approach Segment, in order to facilitate the interception of the extended Final Approach Segment from a radar vector (e.g. VTF function). This capability is not required for RNP APCH operations down to LNAV or LNAV/VNAV minima.
 - Note 1: Aircraft equipped with augmented GNSS (SBAS) typically have this capability as they are certified for LPV.
 - Note 2: Irrespective of SBAS equipage, aircraft typically have the capability to intercept (from a heading vector) a selected inbound course to a fix, e.g., final approach course inbound to the FAF.
- The lateral and vertical deviations for steering and monitoring are assumed to be linear for RNP APCH operations down to LNAV and LNAV/VNAV minima. For RNP APCH operations down to LPV minima these deviations must be angular. Criteria exist to accept angular deviations on RNP APCH down to LNAV and LNAV/VNAV minima.
- Waypoint sequencing must be automatic for RNP APCH down to LNAV, LNAV/VNAV minima.
- Waypoint sequencing is not applicable to RNP APCH down to LPV minima, then mode switching occurs from terminal to approach.
- Definitely for VNAV guidance, waypoints must be sequenced when the estimated position crosses the bisector of the legs on either side of the waypoint (DO-229E).
- For waypoint sequencing, no specific cross-track deviation requirements apply.
- There are no specific requirements to prevent early waypoint sequencing.
- Modifying the final approach segment shall disable the approach mode (DO-229E).
- Switching to Approach mode must occur when (DO-229E):
 - VTF has been selected, or
 - On an approach procedure AND FAWP (i.e., FAF) or MAPt AND if FAWP is the active waypoint the bearing is within 45 degrees of the final approach track.

- Approach path definition (DO-229E):
 - If the pilot has not selected a VTF approach, deviations shall be provided with respect to the active leg of the approach procedure.
 - If the pilot has selected a VTF approach, deviations shall be provided relative to the inbound course to the FAF. The active waypoint shall initially be the FAWP (i.e., FAF). The equipment should also account for short turns onto the final approach where the FAF may not be crossed. Note that the latter is a recommendation only.
 - If the pilot has selected Direct-To the FAWP (i.e., FAF), and the difference between the desired track and the desired track of the final approach segment is greater than 45 degrees, the equipment shall indicate that the FAWP will not be sequenced (the intercept angle at the FAWP is too sharp). In this case, the equipment shall suspend automatic sequencing.

3.2 Findings from Citation Flight Test

On March 22, 2017 a flight was performed to Eelde (EHGG) with the NLR Citation II PH-LAB equipped with a Universal UNS1Fw Flight Management System, with a current database (1705). Eelde has published RNAV procedures (LNAV, LNAV/VNAV, LPV) to runways 05 and 23, see appendix.

At the time of the flight the ATIS reported: EHGG ATIS M RWY23 TL45 10005 KTS 080VAR140 10KM NSC 9/-3 Q1014.

At 2000 ft the wind was a bit stronger, approximately 12020 KTS.

To investigate the influence of intercept angle, intercept altitude, intercept distance and SBAS versus Baro-VNAV, a test card with the following test matrix was used:

Run#	Description	FMS LoS	App Act	Speed	Intercept	Altitude (ft)	Intercept angle
1.	RNAV nominal run	LNAV	MAN	180	8 NM	2000	30°
2.	Normal line-up	LNAV	MAN	180	8 NM	1500	45°
3.	Intercept within FAF	LNAV	MAN	160	5 NM	1500	30°
4.	Intercept within FAF SBAS (if possible check effect of close downwind prior final vector)	LPV	MAN	160	5 NM	1500	30°
5.	Intercept published final approach track @ 3000 ft	LNAV	MAN	180	11 NM	3000	30°
6.	Intercept published final approach track @ 3000 ft	LPV	MAN	180	11 NM	3000	30°

Run#	Description	FMS LoS	App Act	Speed	Intercept	Altitude (ft)	Intercept angle
7.	Added straight/3deg 'transition' to altitude 3000 ft. Intercept between 3000 ft point and FAF	LNAV	AUTO	180	8 NM	2500	30°
8.	Spare for run #1-7						
9.	If time permits; As # 7 with intercept at 2000 ft	LNAV	AUTO	170	8 NM	2000	30°

Intercepts were done on "own navigation", meaning ATC did not assign intercept headings. No other traffic was flying at the time of the flight, meaning the test points could be set up by the crew according to the test matrix.

A total of 11 runs were flown, the data of these runs is presented in Appendix B.

From these runs the following observations were made:

1. When intercepting the vertical path of the final approach segment of the RNAV approach, there is no discernible difference between intercepting a BaroVNAV vertical path (LNAV, LNAV/VNAV) or an SBAS vertical path (LPV).
2. Transitioning from (enroute) BaroVNAV to (approach) SBAS for an LPV approach did not result in any problems. During the flight both QNH and temperature were approximately as in ISA, in very high temperatures and QNH the aircraft may end up above the glidepath on such a transition when the lateral intercept does not provide sufficient space before the glidepath intercept point.
3. Intercepting the final approach laterally without passing abeam the IF will not arm the final approach. In such a scenario the approach will not be available for capture. On the EHGG published approach the IF was located at 10 NM and the FAF was located at 6 NM. Lateral intercepts were attempted at 11, 8, 6 and 5 NM. Intercepts inside the IF were only successful if the aircraft passed abeam the IF.
4. Assuming the aircraft intercepts the glidepath from below, intercepting the final approach vertically at an altitude above or below the Final Approach Altitude is possible. In the trials the FAA was 2000 ft, successful intercepts were made at 1500, 2000, 2500 and 3000 ft.
5. Intercepting the lateral path of the final approach with a 45° intercept angle leads to a significant overshoot. This is an autopilot feature, as the same behavior is observed when intercepting an ILS localizer.

These results are not generally applicable, another FMS and another aircraft guidance system may yield different results. Nevertheless, the results show that a short intercept (without passing abeam the IF) is something that is not advisable, the crew may get into trouble in getting the correct guidance for the approach.

3.3 Findings from Aircraft Systems

3.3.1 FMS, differences between manufacturer

Differences are found between FMS manufacturers especially in naming conventions for specific steps in the process of setting up the aircraft for approach to landing. The following main differences were found, considering contemporary flight management systems in general aviation and larger business regional application.

Garmin [32] refers to 'loading' the approach from the set associated with a destination, preparing the approach for being 'executed', i.e. actually appending it to the active flight plan; this may include any desired transition (IAF waypoint prior to the final approach path). Changeover from en-route to terminal operation (i.e. changing displacement sensitivity) occurs at 30 NM from the destination airport. Transition to final approach displacement gain is at 2 NM inbound to the FAF.

Universal [33] refers to manual or automatic 'arming' of the approach which indicates transitioning from 'en-route' to 'terminal' operation (displacement gains), following the same 30 NM criterion. Subsequently, the approach is 'activated', indicating that it has become appended to the active flight plan. Approach activation implies operation of the transition, i.e. flying the waypoints prior to the final approach segment. The Universal FMS allows intercept headings into the final approach with track angle error $<80^\circ$ (or $<15^\circ$ if older autopilot version is installed). If the final turn into the approach is larger (i.e. $>80^\circ$), then the FMS will perform the turn and, once passing 80° (or 15°), activate the approach when inside 0.3 NM cross track deviation.

Rockwell Collins [34] uses 30 NM distance from the airport criterion for transitioning system displacement gains from en-route to terminal. 'Loading' the approach procedure and any transition precedes 'activation' of the procedure, i.e. appending it to the active flight plan. When meeting the capture criteria (intercept heading $<45^\circ$, 2 NM from FAF) the approach is 'enabled' signifying tracking of the final approach path and sequencing towards the MAP if inside 1.6 NM deviation and at less than 3000' above the FAF.

These differences should be subtle and in general the main logics are found to be comparable. The joint set of conditions for RNAV approach path tracking from FAF to MAP are summarized in Figure 3-1.

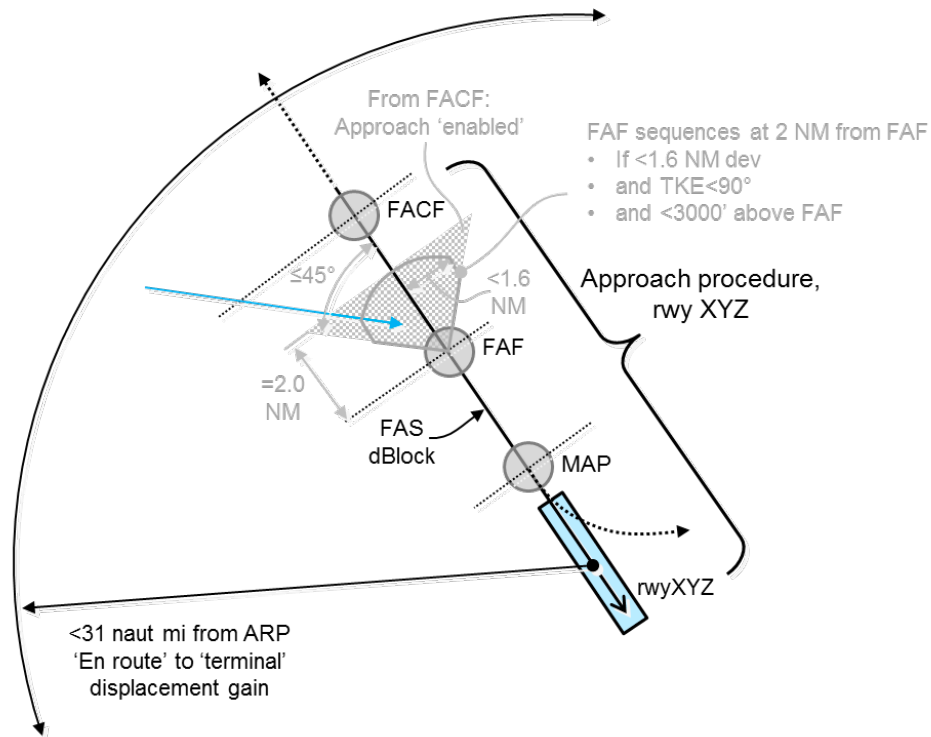

Figure 3-1: Joint RNAV approach path tracking conditions

3.3.2 Summary

Different combinations of FMS and AFGCS have been reviewed in context of RNAV approach operations. In general the logic applied in selecting and activating the desired approach including transitioning from 'en-route' to 'terminal' operations and subsequently from terminal operations to approach operations are found to be fully comparable. Some differences occur in the detailed logics associated with enabling /activation/capturing of the approach path, but in general the analogy with ILS operation can be made. If approach leg sequencing does not take place because the logic conditions are not met, then the aircraft will continue to operate in its previous navigation guidance function.

4 Conclusions and Recommendations

When investigating regulations, aircraft guidance and operational procedures, it is obvious that there are many subtle or less subtle differences in implementation across different FMS and aircraft types. Nevertheless, it is possible to derive a number of conclusions and recommendations that are generally applicable.

Conclusions:

1. There are differences both in terminology and in logic between different FMS manufacturers and aircraft interfaces when describing system behavior and operation related to RNAV approach operations, but in general these differences are small and overall the analogy with ILS operations can be made.
2. When ATC clears the aircraft for an "RNAV approach", depending on aircraft equipment and operational approvals held by the operator and/or crew, the aircraft will fly an approach to LPV minima, to LNAV/VNAV minima (using either Baro-VNAV or SBAS-VNAV), or to LNAV minima (without vertical guidance), this is transparent to ATC. However, different regulations and design criteria apply to aircraft guidance and (short) intercept capabilities.
3. ATC tactical interventions in the terminal area may include radar headings to intercept the initial or intermediate legs of the approach.
4. 'Direct to' clearances may be given to the IAF or IF, not to the FAF.
5. The FAF is a special waypoint, the aircraft must approach the final approach track 2 NM before the FAF, with an intercept angle of not more than 45°, and an XTE less than 1.6 NM.
6. The aircraft can intercept the vertical path at, below or above the published Final Approach Altitude (FAA). An intercept of the vertical path below the FAA will however not change the FAF and associated enabling/sequencing criteria of the RNAV approach. Therefore, vectoring to a lower altitude followed by a shorter intercept (i.e. inside the FAF) is not possible for RNAV approach operations contrary to ILS operations.
7. Intercepting the glide path from above is operationally not recommended.
8. A clearance for an RNAV approach means the crew can decide, depending on aircraft equipment and operational conditions and approvals, if it will fly the vertical path using SBAS or using Baro-VNAV. To cater for possible discontinuities when transitioning from a barometric to a geometric path, ATC should clear the aircraft for approach when below the transition level and already flying on QNH.

Recommendations:

When considering vector-to-final operations, the following recommendations are made:

- The procedure should contain an Initial Fix (IF), the vectoring path should make sure the aircraft has passed abeam the IF;
- The aircraft may be vectored to intercept the final approach track at the latest 2 NM before the FAF, with an angle of not more than 45°;
- Vertically the aircraft can intercept the approach path at any altitude, not necessary restricted to the published Final Approach Altitude, but an intercept from above should be avoided;
- When clearing the aircraft for the approach, the aircraft should be below the transition level (altimeter reference is local QNH).

5 References

- [1] ICAO, Doc 9613, PBN Manual, 4th Edition, 2013.
- [2] EASA, AMC 20-27, Airworthiness Approval and Operational Criteria for RNP APPROACH (RNP APCH) Operations including APV BARO-VNAV Operations, 2009.
- [3] EASA, AMC 20-28, Airworthiness Approval and Operational Criteria related to Area Navigation for Global Navigation Satellite System approach operation to Localizer Performance with Vertical guidance minima using Satellite Based Augmentation System, 2012.
- [4] EASA, EASA Certification Memorandum CM-AS-002, Issue: 02, Clarifications to AMC 20-27, 2014.
- [5] EASA, Air Operations Regulation, EASA Decisions 2016/014/R to 2016/021/R, 2016.
- [6] FAA, AC 20-138D, Change 2, Airworthiness Approval of Positioning and Navigation Systems, 2016.
- [7] FAA, AC 90-105A, Approval Guidance for RNP Operations and Barometric Vertical Navigation in the U.S. National Airspace System and in Oceanic and Remote Continental Airspace, 2016.
- [8] FAA, AC 90-107, Guidance for Localizer Performance with Vertical Guidance and Localizer Performance without Vertical Guidance Approach Operations in the U.S. National Airspace System, 2011.
- [9] RTCA, Inc, DO-229E, Minimum Operational Performance Standards for Global Positioning System/Satellite-Based Augmentation System Airborne Equipment, 2016.
- [10] RTCA, DO-283B, Minimum Operational Performance Standards for Required Navigation Performance for Area Navigation, 2015.
- [11] ICAO, Doc 8168, Procedures for Air Navigation Services Aircraft Operations, Volume I Flight Procedures, 5th Edition up to and including amendment 7, 2016.
- [12] Airbus, A318 to A321 Flight Crew Training Manual (FCTM), 2008.
- [13] Airbus, A330/A340 Flight Crew Operating Manual (FCOM), 2016.
- [14] Airbus, A330/A340 Flight Crew Training Manual (FCTM), 2016.
- [15] Airbus Flight Operations Support and Line Assistance, Getting To Grips with Modern Navigation, 2002.
- [16] Airbus Flight Operations Support and Services, Getting To Grips with RNP AR, 2009.
- [17] Boeing, Boeing 737-700/800/900 Flight Crew Operating Manual (FCOM), 2017.
- [18] Boeing, Boeing 737-700/800/900 Flight Crew Training Manual (FCTM), 2016.
- [19] Boeing, Boeing 777 Flight Crew Operating Manual (FCOM), 2017.
- [20] Boeing, Boeing 777/787 Flight Crew Training Manual (FCTM), 2016.

- [21] Boeing, Boeing 787 Flight Crew Operating Manual (FCOM), 2017.
- [22] Embraer, Airplane Operations Manual E190, 2008.
- [23] Universal Avionics, Operator's Manual SCN 1000 and 1100 FMS, 2010.
- [24] Universal Avionics, Operator's Training Manual for SCN 1000 and 1100 FMS, 2011.
- [25] Rockwell Collins, FMS-3000 Operator's Guide, 2006.
- [26] Garmin, Garmin 1000 Integrated Flight Deck Pilot's Guide, 2008.
- [27] Garmin, Garmin 1000 Integrated Flight Deck Training Guide, 2008.
- [28] Garmin, Garmin G400w Series Pilot's Guide and Reference, 2006.
- [29] AEEC, "Navigation System Database, ARINC specification 424-21," SAE ITC, Bowie, Maryland 20715 USA, 2016.
- [30] ICAO, "Annex 6, Operation of Aircraft, 10th edition, 2016," ICAO, Montreal, Quebec, Canada, 2016.
- [31] Airlines Electronic Engineering Committee - AEEC, "Advanced Flight Management System, ARINC CHARACTERISTIC 702A-3," AERONAUTICAL RADIO, INC., Annapolis, Maryland 21401-7435, USA, 2006.
- [32] Garmin, Garmin GNS480, 560-0984-01_G, Olathe, Kansas 66062, USA: Garmin International, Inc., 2015.
- [33] Universal Avionics, FLIGHT MANAGEMENT SYSTEM (FMS) SCN-1000 SERIES, Report 3044sv1000/1100, Tucson, AZ 85756, USA: UNIVERSAL AVIONICS, SYSTEMS CORPORATION, 2009.
- [34] Rockwell Collins, FMS-6000 v4.0 Flight Management System, 5230809284, Cedar Rapids, Iowa 52498-0001, USA: Rockwell Collins, 2009.
- [35] FAA, US, "Aeronautical Information Manual, chptr 5-4-5 (7), TERPS criteria," Superintendent of Documents, U.S. Government Printing Office, P.O. Box 979050, St. Louis, MO 63197-9000, 2014 (03 apr).

Appendix A Approach Charts EHGG

During the flight trials (see section 3.2) the following approaches were flown:

1. EHGG RNAV 05 (AD2.EHGG-IAC-05.1) 15 SEP 2016
2. EHGG RNAV 23 (AD2.EHGG-IAC-23.23.3) 15 SEP 2016

AIP NETHERLANDS EELDE INSTRUMENT APPROACH CHART RNAV (GNSS) RWY 05 AD 2.EHGG-IAC-05.1 15 SEP 2016

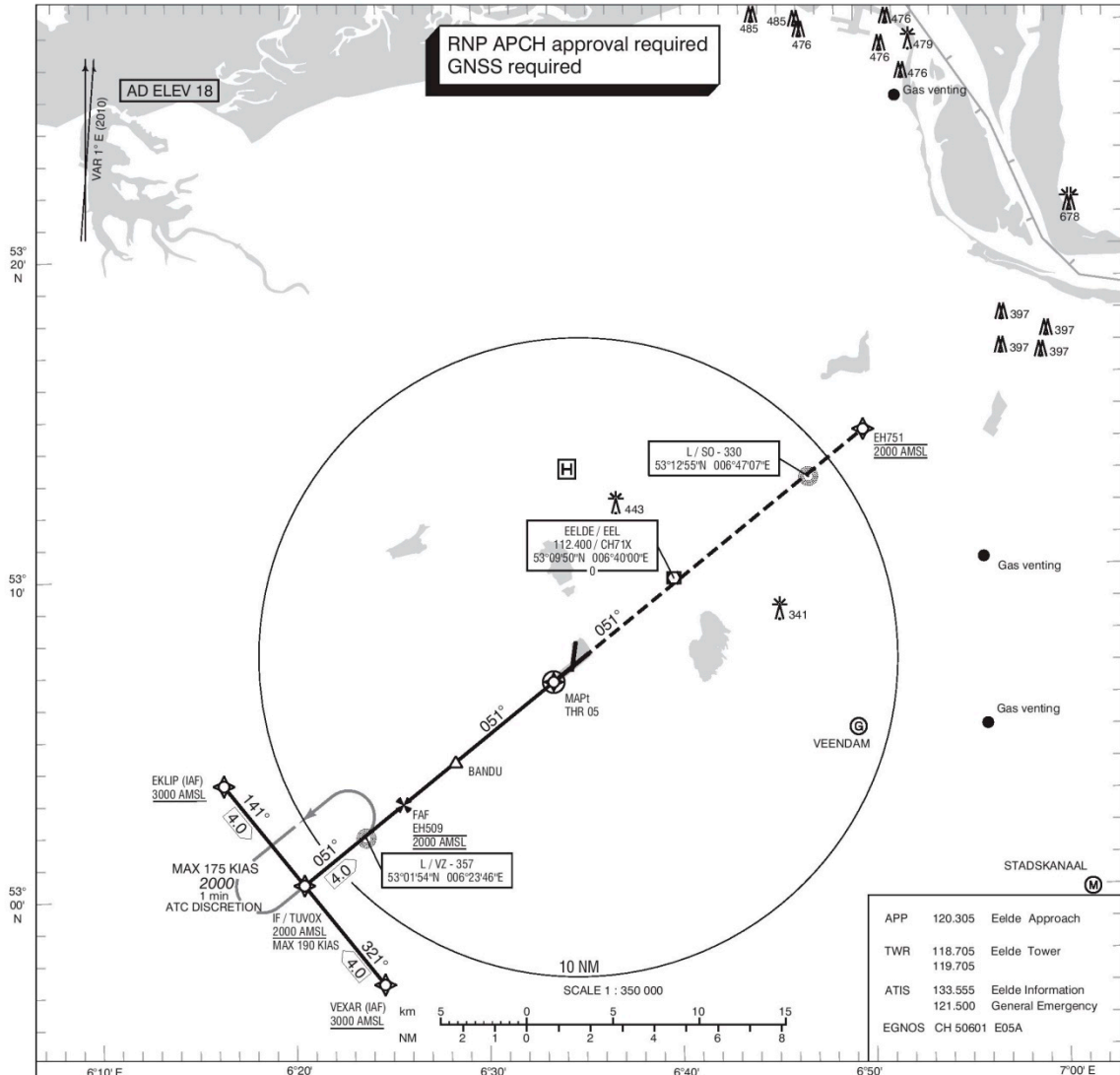

- Missed Approach:
 - Track 051° MAG and climb to 2000 ft AMSL. Inform ATC.
- Missed Approach in case of communication failure:
 - Track 051° MAG and climb to 3000 ft AMSL;
 - When passing 2000 ft AMSL start a left turn to 320° MAG;
 - When reaching 3000 ft AMSL proceed to VZ;
 - After arriving over VZ hold or descend to 2000 ft AMSL in an outbound turn, intercept final approach and execute the instrument approach procedure again.

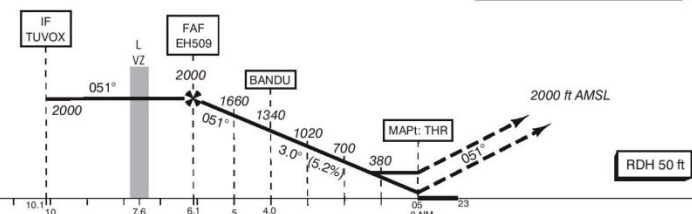

GS IN KT	60	80	100	120	140	160	180
VERTICAL SPEED	320 ft/min	425 ft/min	530 ft/min	635 ft/min	745 ft/min	850 ft/min	955 ft/min

OCA (OCH) ELEV THR 05: 13.3 ft

ACFT CAT	LPV	LNAV/VNAV MNM TEMP -15°C	LNAV	CIRCLING*	THR 05 53°06'40"N 006°33'39"E EH509 53°02'54"N 006°25'44"E EH751 53°14'22"N 006°50'01"E
A	313 (300)	320 (307)	440 (420)	450 (430)	
B	313 (300)	320 (307)		520 (500)	
C	313 (300)	320 (307)		620 (600)	
D	313 (300)	320 (307)		840 (830)	

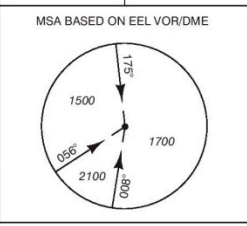

CEILING AND VISIBILITY MINIMA

TAKE-OFF DAY:	DAY:	NIGHT:	DAY:	NIGHT:
	NA		NA	

* Circling approaches shall be executed south-east of the AD, unless otherwise instructed by ATC.

BEARINGS ARE MAGNETIC DISTANCES IN NM ALTITUDES AND ELEVATIONS IN FEET

CHANGE: COM channels: editorial.

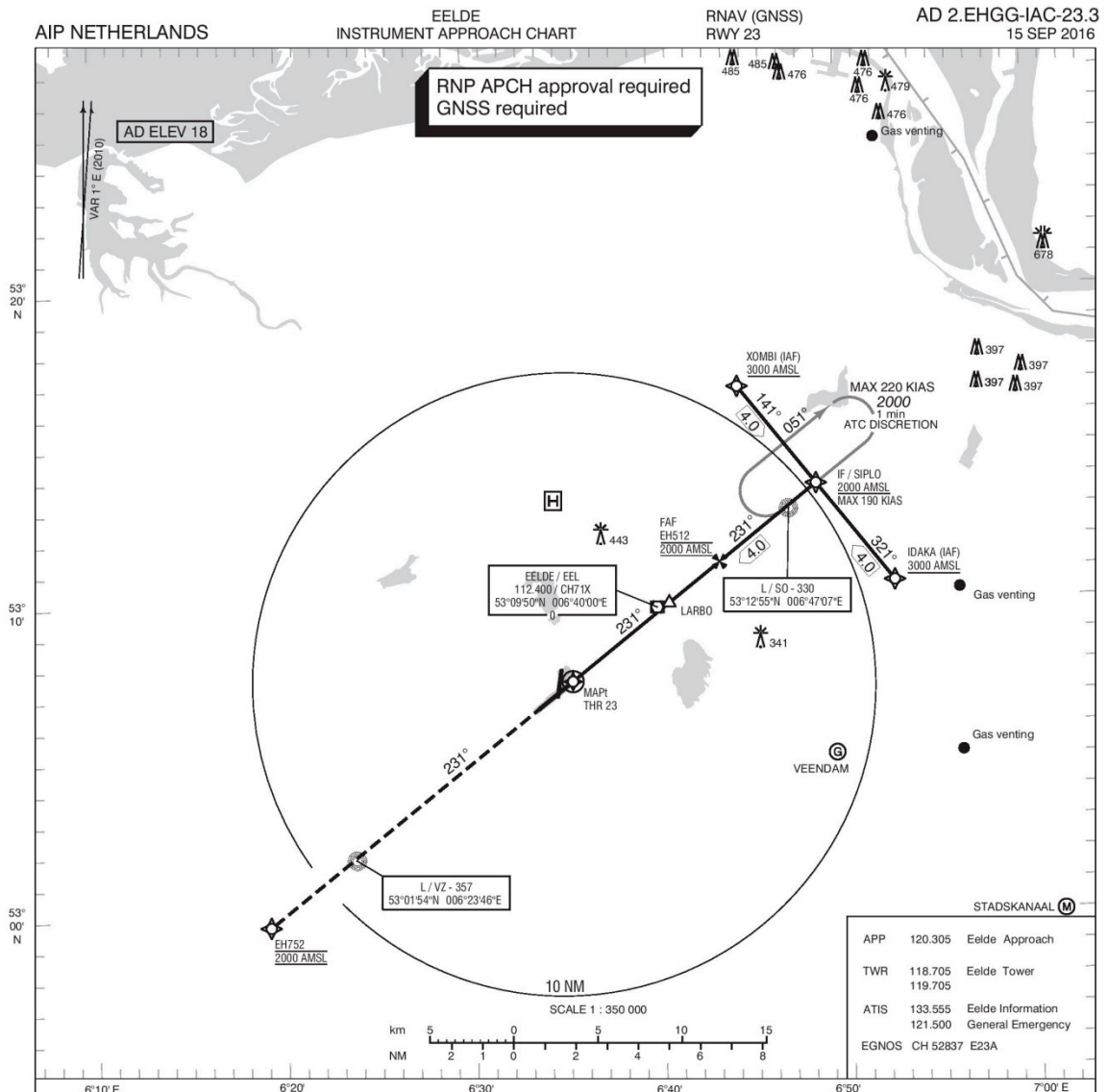

TRANSITION LEVEL BY ATC
TRANSITION ALTITUDE 3000 ft AMSL

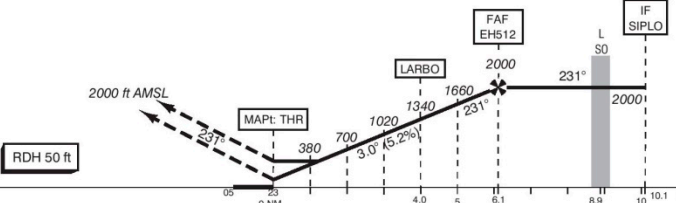

GS IN KT	60	80	100	120	140	160	180
VERTICAL SPEED	320 ft/min	425 ft/min	530 ft/min	635 ft/min	745 ft/min	850 ft/min	955 ft/min

OCA (OCH) ELEV THR 23: 12.5 ft				
ACFT CAT	LPV	LNAV/VNAV MNM TEMP -15°C	LNAV	CIRCLING*
A	263 (250)	280 (268)	440 (430)	450 (430)
B	263 (250)	290 (278)		520 (500)
C	263 (250)	300 (288)		620 (600)
D	263 (250)	310 (298)		840 (830)

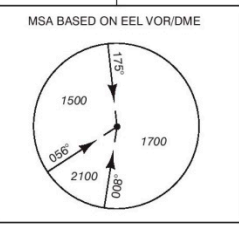

CEILING AND VISIBILITY MINIMA			* Circling approaches shall be executed south-east of the AD, unless otherwise instructed by ATC.	BEARINGS ARE MAGNETIC DISTANCES IN NM ALTITUDES AND ELEVATIONS IN FEET
TAKE-OFF	DAY: NA	NIGHT: NA		
LANDING	DAY: NA	NIGHT: NA		

© Air Traffic Control the Netherlands

AIRAC AMDT 10/2016

CHANGE: COM channels: editorial.

Appendix B Flight Test Results

Appendix B.1 Run 1 - Nominal

Run#	Description	FMS LoS	App Act	Speed	Intercept	Altitude (ft)	Intercept angle
1.	RNAV nominal run	LNAV	MAN	180	8 NM	2000	30°



This approach was made to runway 05, the actual intercept of the lateral path of the final approach was at approximately 7 NM and was uneventful.

Appendix B.2 Run 2 – 45° intercept

Run#	Description	FMS LoS	App Act	Speed	Intercept	Altitude (ft)	Intercept angle
2.	Normal line-up	LNAV	MAN	180	8 NM	1500	45°



On this run the 45° intercept was flown to runway 23 with a lefthand pattern, meaning on the intercept leg a tailwind of approximately 20 knots was present resulting in a groundspeed of approximately 200 KTS, relatively high for the Citation autopilot. The line-up resulted in a significant overshoot (maximum XTE was 0.28NM) which the pilots qualified as “unacceptable”.

It was not clear if this was due to the wind (and therefore high groundspeed), the FMS capture logic or the autopilot capture logic, therefore it was decided to repeat this run at the end of the program using the localizer beam instead of the LNAV path (run 11) and with an intercept with headwind (run 9).

Appendix B.3 Run 3 – Intercept inside the FAF (BaroVNAV)

Run#	Description	FMS LoS	App Act	Speed	Intercept	Altitude (ft)	Intercept angle
3.	Intercept within FAF	LNAV	MAN	160	5 NM	1500	30°



On this run the intercept was inside the FAF. The selected approach (RNAV 05) was selected in the FMS and the approach was activated by the crew, as per SOPs for a radar vectored line-up to final. The FMS then creates an extended path to TUVOX, and TUVOX becomes the active waypoint.

Because the short line-up TUVOX was not passed, the crew attempted on the baseleg to make the segment EH509-THR05 the active leg. The result of this was that the approach activation was cancelled by the FMS. A second setup was made, reloading the approach and manually activating the approach, but this repeated the problem: manual activation of the approach makes the inbound leg to TUVOX the active leg, and trying to change the active leg results in the approach deactivated by the FMS.

Only on the third attempt, when the XTE was approximately 0.8 NM and distance to THR was 5 NM, the FMS sequenced to EH509-THR05 as the active leg. The identified problem is that the FMS, as per ARINC 424 specification, contains a protected approach segment. When the pilot tries to manipulate the flight plan inside the protected

segment, the approach activation is automatically cancelled and XTE deviations will not be according to the intended flight path. See the following figure: the protected part of the approach is identified by the pseudo-waypoint *RNV 05* and contains the IF, FAF and MAWP. The altitude over the IF is calculated by the FMS.

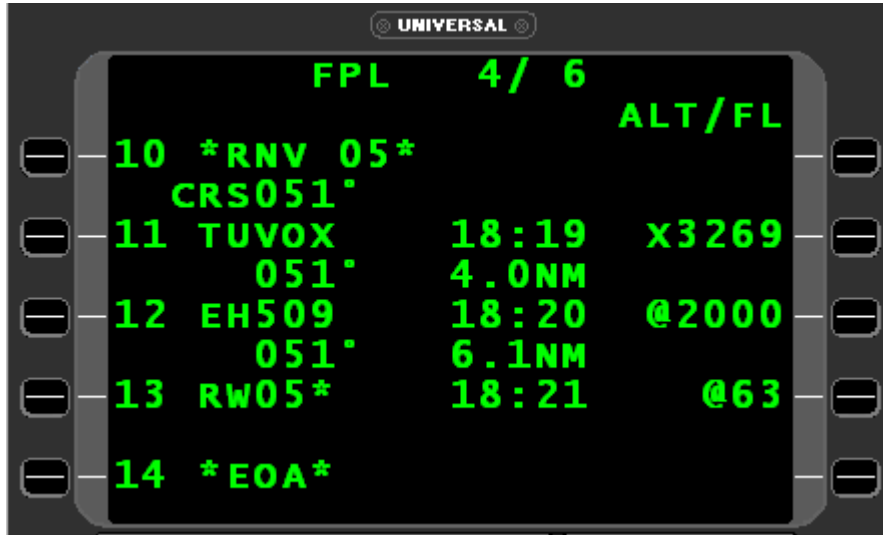

The result will be that the approach cannot be captured when radar vectored inside the IF.

The third attempt was made when the aircraft was almost on the final track, so no intercept was required.

Appendix B.4 Run 4 – Intercept inside the FAP (SBAS)

Run#	Description	FMS LoS	App Act	Speed	Intercept	Altitude (ft)	Intercept angle
4.	Intercept within FAF SBAS (if possible check effect of close downwind prior final vector)	LPV	MAN	160	5 NM	1500	30°



This run confirmed the problems encountered on the previous run: on an intercept inside the FAF, and in particular when radar vectored inside IF, it is not possible to select FAF-MAWP as the active leg, as a result it is not possible to capture the final approach.

The overshoot shown was the result of manually flying towards the final approach path by the Pilot Flying, while the Pilot Not Flying manipulated the FMS to attempt to get proper guidance.

There was no discernible difference between BaroVNAV (run 3) and SBAS (run 4) vertical guidance.

Appendix B.5 Run 5 – Intercept outside the IF (Baro VNAV)

Run#	Description	FMS LoS	App Act	Speed	Intercept	Altitude (ft)	Intercept angle
5.	Intercept published final approach track @ 3000 ft	LNAV	MAN	180	11 NM	3000	30°



Compared to the previous two runs here the FMS active leg after approach activation can be intercepted therefore no problems were encountered.

The FMS extends the final approach 3° vertical path leading to a TUVOX calculated nominal altitude of 3269 ft, therefore the 3° final approach BaroVNAV path is intercepted about 1 NM after passing TUVOX

When the aircraft was established on final approach and well passed the FAF, the approach was discontinued.

Appendix B.6 Run 6 - Intercept outside the IF (SBAS)

Run#	Description	FMS LoS	App Act	Speed	Intercept	Altitude (ft)	Intercept angle
6.	Intercept published final approach track @ 3000 ft	LPV	MAN	180	11 NM	3000	30°



In-flight it was decided to attempt a line-up between the IF and FAF from 3000 ft. Laterally it is a repeat of Run 1, vertically the intercept was made above the FAA, and using SBAS.

There were no problems with such an intercept. The vertical path is followed using Enroute VNAV (=BaroVNAV), when the approach mode captures the lateral path, the final approach SBAS path becomes available. Transitioning from BaroVNAV to SBAS is uneventful, although it must be noted that during the flight the temperature was almost ISA and the QNH 1010 hPa. In very high temperatures and QNH the aircraft may end up above the glidepath on such a transition when the lateral intercept does not provide sufficient space before the glidepath intercept point.

Appendix B.7 Run 7 – Intercept outside the IF, auto-activation (BaroVNAV)

Run#	Description	FMS LoS	App Act	Speed	Intercept	Altitude (ft)	Intercept angle
7.	Added straight/3deg 'transition' to altitude 3000 ft. Intercept between 3000 ft point and FAF	LNAV	AUTO	180	8 NM	2500	30°



This run is similar to the previous run 5 (BaroVNAV) and 6 (intercept between IF and FAF at 2500 ft), with the exception that the crew does not manually activate the approach. The FMS logic will auto-activate the approach within 2 NM of the FAF. Once established on the final approach, and passed the FAF, the approach was discontinued.

Appendix B.8 Run 8 - Intercept outside the IF, auto-activation (SBAS)

Run#	Description	FMS LoS	App Act	Speed	Intercept	Altitude (ft)	Intercept angle
8.	Added straight/3deg 'transition' to altitude 3000 ft. Intercept between 3000 ft point and FAF	LPV	AUTO	180	8 NM	2500	30°



Similar to run 7, but with SBAS. The transition between (enroute) BaroVNAV and (approach) SBAS was uneventful and transparent, the vertical 3° final approach path is captured on the segment IF-FAF from 2500 ft.

Appendix B.9 Run 9 - 45° intercept (headwind)

Run#	Description	FMS LoS	App Act	Speed	Intercept	Altitude (ft)	Intercept angle
9.	Normal line-up	LNAV	MAN	180	8 NM	1500	45°



Run 2 yielded a significant overshoot when intercepting the final approach track at an intercept angle of 45°. With headwind (20015 KTS) and a groundspeed of approximately 170 KTS the overshoot was not seen.

Appendix B.10 Run 10 – Long intercept inside FAF

Run#	Description	FMS LoS	App Act	Speed	Intercept	Altitude (ft)	Intercept angle
10.	Intercept within FAF	LNAV	MAN	160	5 NM	1500	30°



This run was a repeat of run 3, but with the difference that the short line-up was initiated with the aircraft beyond abeam the IF. When activating the approach the active leg becomes the inbound leg to the IF, when the aircraft passes abeam the IF, the leg IF-FAF becomes the active leg, and when the aircraft passes abeam the FAF, the leg FAF-MAWP becomes the active leg. Leg sequencing is correct, final approach is intercepted at approximately 4 NM (inside the FAF).

Appendix B.11 Run 11 - 45° intercept (tailwind, localizer)

Run#	Description	FMS LoS	App Act	Speed	Intercept	Altitude (ft)	Intercept angle
11.	Normal line-up	LNAV	MAN	180	8 NM	1500	45°



Run 2 showed a significant overshoot in tailwind conditions when intercepting the final approach course, run 9 showed that this overshoot was not present in headwind conditions. This run is a repeat of run 2, except that not the RNAV final approach path was captured but the ILS localizer. With a groundspeed of 200 KTS also the localizer is overshoot significantly, showing that the overshoot is due to autopilot capture logic and not related to the approach type.

NLR

Anthony Fokkerweg 2

1059 CM Amsterdam, The Netherlands

p) +31 88 511 3113 f) +31 88 511 3210

e) info@nlr.nl i) www.nlr.nl