



NLR TP 96239 U

Integrated Free Flight and 4-D Gate-to-gate Air Traffic Management, Possibilities, Promises and Problems

F.J. Abbink

DOCUMENT CONTROL SHEET

	ORIGINATOR'S REF. TP 96239 U		SECURITY CLASS.												
ORIGINATOR National Aerospace Laboratory NLR, Amsterdam, The Netherlands															
TITLE INTEGRATED FREE FLIGHT AND 4-D GATE-TO-GATE AIR TRAFFIC MANAGEMENT, POSSIBILITIES, PROMISES AND PROBLEMS															
PRESENTED AT The 9th European Aerospace Congress "Visions and Limits of Long-term Aerospace Developments", organised by CEAS, Berlin, 14-15 May, 1996.															
AUTHORS F.J. Abbink		DATE 960404	<table style="width: 100%; border: none;"> <tr> <td style="text-align: right;">pp</td> <td style="text-align: right;">ref</td> </tr> <tr> <td style="text-align: right;">64</td> <td style="text-align: right;">57</td> </tr> </table>	pp	ref	64	57								
pp	ref														
64	57														
DESCRIPTORS <table style="width: 100%; border: none;"> <tr> <td style="width: 50%;">Air traffic control</td> <td style="width: 50%;">Flight safety</td> </tr> <tr> <td>Airline operations</td> <td>Man-computer interface</td> </tr> <tr> <td>Automated en route ATC</td> <td>Multisensor applications</td> </tr> <tr> <td>Automatic landing control</td> <td>Satellite navigation systems</td> </tr> <tr> <td>Avionics</td> <td>Technology assessment</td> </tr> <tr> <td>Collision avoidance</td> <td>Warning systems</td> </tr> </table>				Air traffic control	Flight safety	Airline operations	Man-computer interface	Automated en route ATC	Multisensor applications	Automatic landing control	Satellite navigation systems	Avionics	Technology assessment	Collision avoidance	Warning systems
Air traffic control	Flight safety														
Airline operations	Man-computer interface														
Automated en route ATC	Multisensor applications														
Automatic landing control	Satellite navigation systems														
Avionics	Technology assessment														
Collision avoidance	Warning systems														
ABSTRACT <p>In the 20th century air transport has developed into a safe, reliable and economic means of transportation for passengers, cargo and mail. In the next two decades, the air transport is forecasted to double. To enable this expansion to occur within the limited airspace, with the limited number of airports and runways and with the increasing requirements with respect to safety, noise and emissions, new technological developments are necessary. The use of satellite-based Communication, Navigation and Surveillance (CNS) systems, combined with further steps towards computer-assisted and automated Air Traffic Management (ATM) with digital datalink between ATM and aircraft computer systems, will be necessary. The introduction of new forward-looking warning systems, the increase of precision on approach and landing systems and the improvement of procedures and training levels will be required to improve the safety level. The availability of on board "traffic displays" will allow the flight crew to take care of maintaining safe separation between aircraft, even in reduced visibility conditions. This might lead to more freedom for the flight crew to optimize flight operations. The human will become more and more a system operator who monitors the correct operation of airborne and ground-borne systems. The human must also be able to take over in case of malfunctions. This requires adequately trained individuals adequate display and control systems. Improved Man-Machine Interfaces will have to be introduced to present the data in an organized, natural and intuitive way. The paper describes the development of aviation into today's reliable air transport system and the developments and research required to enable the growth forecasted for the next decades to be realized.</p>															



Summary

In the 20th century air transport has developed into a safe, reliable and economic means of transportation for passengers, cargo and mail.

In the next two decades, the air transport is forecasted to double. To enable this expansion to occur within the limited airspace, with the limited number of airports and runways and with the increasing requirements with respect to safety, noise and emissions, new technological developments are necessary.

The use of satellite-based Communication, Navigation and Surveillance (CNS) systems, combined with further steps towards computer-assisted and automated Air Traffic Management (ATM) with digital datalinks between ATM and aircraft computer systems, will be necessary.

The introduction of new forward-looking warning systems, the increase of precision on approach and landing systems and the improvement of procedures and training levels will be required to improve the safety level.

The availability of on board "traffic displays" will allow the flight crew to acquire an improved "traffic awareness" and potentially to take care of maintaining safe separation between aircraft, even in reduced visibility conditions. This might lead to more freedom for the flight crew to optimize flight operations.

The human will become more and more a system operator who monitors the correct operation of airborne and ground-borne systems. The human must also be able to take over in case of malfunctions. This requires adequately trained individuals with adequate display and control systems. Improved Man-Machine Interfaces will have to be introduced to present the data in an organized, natural and intuitive way.

The paper describes the development of aviation into today's reliable air transport system and the developments and research required to enable the growth forecasted for the next decades to be realized.

Table of contents

1	Introduction	7
2	Development of air transport	9
2.1	The first 25 years: The development of the airliner	9
2.2	The introduction of electronics in aviation	10
2.3	The 1930s: blind flight and metal airliners	11
2.4	The Second World War: radar, jet engines and digital computers	11
2.5	International standardisation and Air Traffic Control	12
2.6	Jet airliners, integrated instruments and automatic landing	13
2.7	Digital avionics and Fly-by-Wire	15
3	Development of scheduled airline production, safety and environmental aspects from 1970 - 1995	17
3.1	Scheduled airline production	17
3.2	Scheduled airline safety	18
3.3	A safety net of Warning Systems	19
3.4	Present-day Air Traffic Control	21
3.5	Aircraft emissions and noise	22
4	Air transport growth in the next decades, problems and solutions	24
4.1	Forecasted growth	24
4.2	New generation of airliners	25
4.3	Improved safety	26
4.3.1	Necessity and strategy to improve air transport safety	26
4.3.2	Improved warning systems	27
4.3.3	Synthetic and Enhanced Terrain Vision	29
4.3.4	Integrated Outside Vision System	32
4.4	Improving the capacity of the airspace by integration and by the use of satellite-based Communication, Navigation and Surveillance	34
4.4.1	Harmonisation and integration of European ATC	34
4.4.2	Satellite-based Communication, Navigation and Surveillance	35



4.5	Increasing the capacity of airports and reducing noise and emissions	36
4.5.1	General	36
4.5.2	Precision approach and landing systems	39
4.5.3	Precision Radar Surveillance Systems	41
4.5.4	Optimal sequencing of approaching aircraft	42
4.5.5	Reduction of fuel consumption, emission and noise through Continuous Descent Approaches	45
5.	Integrated free flight and 4D gate-to-gate ATM	48
5.1	National Route Program	48
5.2	Use of TCAS for In-Trail Climb	48
5.3	Free Flight	49
5.4	Integrated Free Flight and 4D Gate-to-Gate ATM	49
6	Required ATM research and research facilities	51
7	Conclusions	56
8	References	58
9	Abbreviations and acronyms	61

1 Introduction

Since the development of civilisation the transport of people, cargo and information was of vital importance to mankind.

Already in the nineteenth century technical developments had provided great progress in the area of means of transportation. The steam engine had enabled a fast, reliable transportation across the continents by train and the crossing of seas by ships independent of the wind. The internal combustion engine enabled the automobile to develop towards an important means of transportation for the relatively short distances. In the twentieth century a totally new vehicle was developed: the aircraft. Because of its great speed and competitive economics the aircraft surpassed the train and the ship especially on the medium and long distance for the transport of mail and passengers and of valuable cargo.

In hours destinations can be reached that used to take days or weeks. In 1994 about 700 airlines of the 183 Contracting States of the International Civil Aviation Organization (ICAO) carried about 1,203 million passengers and 20 million tons of freight. International scheduled traffic produced 2086 billion passenger-kilometers, 76.5 billion tonne-kilometres freight and 5.47 billion tonne-kilometres mail corresponding to a total of 271.5 billion tonne-kilometers. The enormous growth of commercial air transport was made possible by the fast development of two relatively young technologies : aeronautics and electronics.

Aeronautical engineering concentrated on the aerodynamic shaping and on the stability and control of the aircraft as well as on new methods of construction and propulsion.

Electronical engineering provided the means to develop the aircraft into a mission-oriented vehicle:

- communication systems
- navigation and landing systems
- automatic flight control
- multi-function colour displays
- digital flight-management and flight-warning computer systems

For the next two decades a doubling of air transport is forecasted. To enable this growth within the limited airspace, the limited number of airports and runways and with the increasing requirements with respect to safety, external noise and emissions new technologic developments are required. The combined use of satellite-based Communication, Navigation and Surveillance systems, computer-assisted and automated Air Traffic Management (ATM) and digital datalinks between ATM and aircraft computer systems may be necessary to increase capacity, safety and efficiency of air transport.

Even automated ATM will require the human to monitor the correct operation of the systems and to take over in case of malfunctions in order to provide the required integrity and availability. To enable the human to do so, improved Man-Machine Interfaces in the aircraft as well as on the ground will be



required. To a large extent the improvements in the Man-Machine Interface will have to be aimed at a more direct interpretation of the available data by presenting this data visually in an organized, more natural, intuitive way.

The paper describes the development of the air transport system to its present status and the required systems to provide for the doubling of the air transport while maintaining a high safety level and limiting the burden to the environment.

2 Development of air transport

2.1 The first 25 years: The development of the airliner

On Thursday December 12, 1903 Orville Wright made the first successful manned flight of a fully controllable aircraft near Kill Devil Hills in North Carolina. The flight took only 12 seconds and was executed with an airspeed of 48 km/hr at an altitude of only several meters above the ground. It ended about 36 meters from the take-off location. But in Orville Wright's own words this flight was *"the first in the history of the world in which a machine carrying a man had raised itself by its own power into the air in full flight, had sailed forward without reduction of speed, and had finally landed at a point as high as that from which it started"* [1].

The Wright Brothers had designed the aircraft for carrying only one person, lying down to reduce drag, for a short low-level flight. They solved the problems of aircraft design, stability, and control, aerodynamic shaping and propulsion in a scientific way. For the aerodynamic design they used a home-built wind tunnel and for the verification of the design they used instrumented flight tests.

Since 1903 an enormous development has taken place. The aircraft structures gradually improved and the engines became more powerful, lighter and more reliable. On July 1909 Louis Blériot ventured the crossing of the English Channel in his single-engined Blériot XI monoplane. The flight took only 36 minutes. But the aircraft with their construction of wood, steel wire and linen were still very fragile. This was shown in September 1908 when the Wright biplane aircraft piloted by Orville Wright crashed at Fort Myer, Virginia because of a structural failure of a propeller. Orville Wright was badly injured [2]. His passenger, Lieutenant Thomas Selfridge of the US Army Signal Corps, was the first person to die as passenger in an aircraft accident.

In September 1909 Eugène Lefebvre crashed his Wright Model A aircraft at Port Aviation Juvisy and became the first pilot of a powered aircraft to die in an aircraft accident [2].

World War I gave an enormous impulse to aviation. The performance of the aircraft measured in maximum flying speed, altitude, payload and endurance increased with great steps. The great development in aircraft performance can be well illustrated by the flight of Captain John Alcock and Lieutenant Arthur Whitten Brown in 1919. They made the first non-stop crossing of the Atlantic in a Vickers Vimy Bomber, flying from St. John's, New Foundland to Clifden Country, Galway in Ireland. The total flying time was 16 hours and 27 minutes.

The great surplus of the over 200,000 aircraft built during World War I and the large number of available trained pilots formed the basis for the new airlines that started to transport mail, passengers and cargo on a commercial basis.

In these early days of commercial aviation the weather was a major factor determining whether or not a flight could be safely executed. The pilot required good visibility for a safe take-off, attitude control, navigation, terrain collision avoidance and avoidance of collision with (the few) other aircraft. Good

visibility was also necessary for the avoidance of areas with adverse meteorological conditions as thunderstorms with lightning and heavy turbulence as well as for take-off and landing. The flights had to be executed in Visual Meteorological Conditions (VMC) in which the pilot could “see and avoid” external dangers.

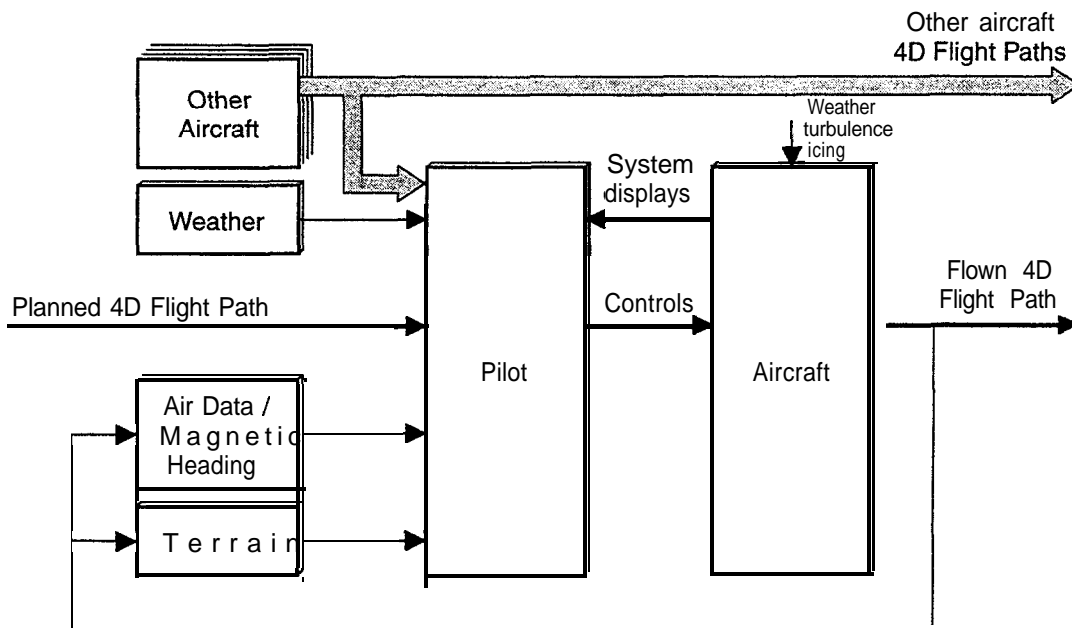

Fig. 1 Flight in Visual Meteorological Conditions

In figure 1 the “control-loop type” block diagram shows the pilot who, using his planned 4D flight path as a reference, controls his aircraft while observing other aircraft, the weather, altitude, airspeed and magnetic heading and the terrain to:

- control the aircraft
- navigate
- avoid collision with terrain
- avoid collision with other aircraft
- avoid bad weather areas

In good visibility conditions, the interpretation of all the information was very straightforward. The pilot used his day-to-day experience during his flights. The outside world seen from the cockpit was easy to interpret.

2.2 The introduction of electronics in aviation

Unfavourable weather and visibility conditions, however, could make safe flight impossible. Radio communication was the obvious way to inform the pilot from the ground about deteriorating weather and visibility conditions. Already in 1916 experiments took place in using radio telephony to communicate between the pilot and the ground. After the war, radio telephony became recognized by

the emerging airlines as an important means for improving safety of operation.

In 1924 the KLM Royal Dutch Airlines introduced Marconi AD-2 radio transceivers in its aircraft. During flight a 60-meter long antenna had to be reeled out. An airscrew driven generator provided the electrical power for the radio transceiver [3].

Although warning the pilot by radio for bad weather and visibility improved the safety of aviation, it did not help to improve the economical requirement of predictable time schedules for the airlines. In bad visibility, flights were cancelled or diverted.

2.3 The 1930s: blind flight and metal airliners

A well directed research project was started to develop blind-flight instruments and blind-flight navigation and landing aids. The introduction of the gyroscopic turn-and-bank indicator was the first step to allow "blind flying". The development of the gyroscopic artificial horizon and directional gyro in 1929 allowed blind flying with an acceptable pilot workload [4].

The combination of blind-flying instruments, the Radio Direction Finder (RDF) and Four-Course Radio-Range beacons allowed safe flight and navigation in bad visibility. To reduce the danger of collisions with terrain and other aircraft, procedures and flight rules were established. In Europe a preliminary air traffic control system based on radio communication and ground-based Radio Direction Finders was developed to make position fixes of the transmitting aircraft.

Deicing and anti-icing systems were introduced to reduce the dangers of ice accretion during flight. Automatic Flight Control Systems reduced the workload of the flight crew related to maintaining altitude, attitude and heading.

In the 1930s the aircraft structure changed dramatically. Boeing, Douglas and Lockheed started to build all-aluminium, twin-engined airliners with a stressed-skin construction, internally braced wings with flaps, radial engines with aerodynamic (NACA) cowlings, controllable-pitch metal propellers and a retractable landing gear. The aircraft were designed so that they could continue flying safely with one engine stopped. The best-known example at this new generation of commercial metal aircraft was the Douglas DC-3.

2.4 The Second World War: radar, jet engines and digital computers

The Second World War gave another enormous impetus to aeronautics. The aircraft was used as an essential tactical and strategic weapon system. Especially for the United Kingdom it was of vital importance to early detect and identify approaching enemy aircraft and to direct the limited number of friendly aircraft towards the enemy forces.

To this purpose the United Kingdom developed an effective radar-based air defence system [5]. A transponder on board the own aircraft allowed Identification Friend or Foe (IFF). Effective radio-navigation systems were introduced that allowed the aircraft to approach their fixed ground targets at night and in bad visibility. At the own air bases, special radio beacons were installed that allowed the

aircraft to approach the runways in bad visibility. This so called Standard Beam Approaching System was the predecessor of the Instrument Landing System.

Later in the Second World War, the fighter aircraft and bomber aircraft were equipped with on-board radar systems, that allowed the pilots to accurately detect and attack their targets. On-board radar proved to be decisive in the detection and suppression of submarines.

Great steps forward were also made in the propulsion and the design of military aircraft. Long-range bomber aircraft were developed. High-speed fighter aircraft, powered by gas turbines or rockets appeared. For these heavy bombers and fast fighters a great number of air bases with long concrete runways were constructed. And finally the digital computer was developed for the breaking of the German Enigma radio-telegraphy codes and for the calculation of the trajectories of ballistic projectiles. These World War II developments provided the basis for the development of post-war international economic commercial air transport.

2.5 International standardisation and Air Traffic Control

In 1947 the International Civil Aviation Organization (ICAO) was founded. Through ICAO an international standardisation was made of standards and procedures for licensing of personnel, rules of the air, Air Traffic Control, meteorological services, certification of new aircraft, etc. [6]. The airspace of the world was divided into Flight Information Regions (FIRs). The nation within the FIR was made responsible for the Air Traffic Control (ATC) within the FIR. Around the major airports in the FIR, so called Control Zones (CTRs) and Terminal Manoeuvring Areas (TMAs) are located. The TMAs are connected by fixed airways or sectors, usually defined by the radials of VHF Omnidirectional Radio Range Beacons (VORs). Distance Measuring Equipment (DME) information is used to complement the VOR directional information.

The flights can be completed by either a precision approach using the Instrument Landing Systems (ILS) or a non-precision approach to a VOR Beacon or Non Directional Beacon (NDB) followed by a "visual" final approach and landing. For the communication between pilots and air traffic controllers a VHF two-way voice radio communication was standardized. For the surveillance of the air traffic, Primary Surveillance Radar (PR), later complemented with Secondary Surveillance Radar (SSR), was introduced.

These VHF Line-of-Sight (LoS) Communication, Navigation and Surveillance (CNS) systems allowed a safe and efficient use of the airspace. Over the oceans and large uninhabited areas where no LoS Communication and Navigation Systems could be used, lower quality High Frequency (HF) voice communication and less accurate Long Range Navigation (LORAN) systems had to be used.



2.6 Jet airliners, integrated instruments and automatic landing

The introduction of straight-jet gas-turbine powered subsonic airliners in the early 1960s provided a quantum jump in the production of air transport. Important examples are the Havilland Comet (1952), the Sud Aviation Caravelle (1955), the Boeing 707 (1957) and the Douglas DC8 (1958). The cruising speed rose to about 900 km/hr and the cruising altitude became about 10 km. The elimination of the vibration of the piston engines and propellers and the flying “above the weather” increased the passenger comfort level significantly.

To avoid areas with bad weather and heavy turbulence, these new aircraft were equipped with weather radar. Integrated electro-mechanical instruments were introduced in the cockpit. The Attitude Director Indicator (ADI) combined the artificial horizon, Flight Director and ILS information. The Horizontal Situation Indicator (HSI) combined magnetic headings, ILS, NDB and VOR directional information. These new integrated instruments allowed the pilot to absorb all required flight and navigation information in an easier way, by a shorter scanning cycle.

For long-range navigation over the oceans and other areas without ground-based Line-of-Sight radio navigation aids, the Boeing 707 and Douglas DC-8 were equipped with the Marconi Doppler Navigation system, in addition to the LORAN-A (hyperbolic) radio-navigation systems.

The Boeing 707 and the Douglas DC-8 were flown by a flight crew of two pilots, a flight engineer, a navigator and occasionally also a radio operator.

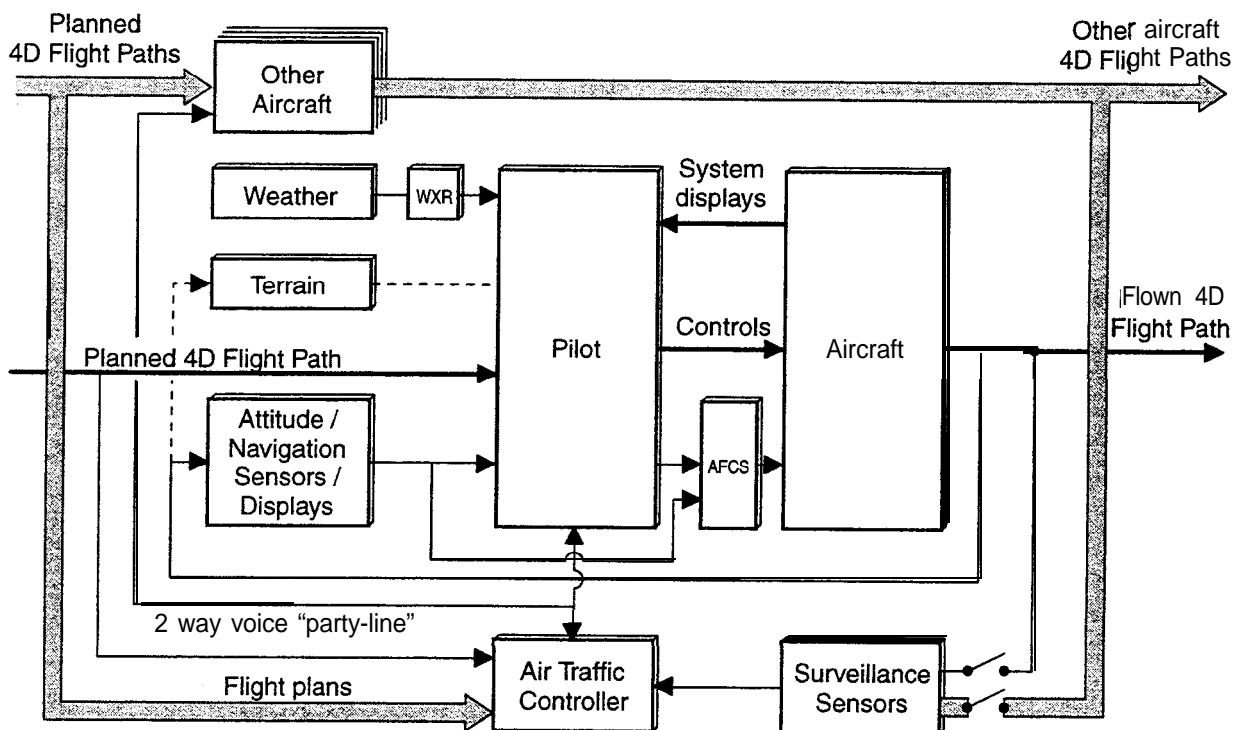

fig. 2 Air Traffic Control for aircraft in IMC



In figure 2 a control-loop diagram is provided for the aircraft and ATC in Instrument Meteorological Conditions (IMC). The pilot uses his planned 4D flight path (provided in a flight plan to ATC and after the ATC clearance) as his reference. He uses his navigation and flight sensors and displays to fly the aircraft along the ATC-cleared 4D flight path. He uses his weather radar to avoid hazardous weather areas. Because in IMC the pilot cannot see the terrain, he has to procedurally maintain an adequate terrain clearance. Because in IMC he also cannot observe the other traffic, he has to rely on ATC to provide an adequate separation with other aircraft.

The Air Traffic Controller is supplied with the flight plans of all the aircraft in his control area. Furthermore through his surveillance sensors (Direction Finding equipment and radars) the Air Traffic Controller can observe the position, direction of flight and altitude of the aircraft. When the pilots of the various aircraft do not comply with their flight plans and cleared flight paths, the Air Traffic Controller has to take action to ensure safe separations between the aircraft. In this "safety control loop" one has to take into account:

- The delays caused by the limited "sampling rates" of the surveillance radars (4-10 sec.).
- The time required by the Air Traffic Controller to detect from a number of observations that one of the aircraft is not complying with the clearance.
- The time required to solve the potential problems and to instruct the affected pilots by VHF two-way voice communication.
- The time required by the affected pilots to react.

Adequate separations between the aircraft are normally necessary to provide enough time for the detection and solution of problems and to maintain a "safe, orderly and expeditious" flow of traffic.

In the United Kingdom a government-sponsored research programme of the Blind Landing Experimental Unit (BLEU) had provided a fully automatic landing system. In 1967 British European Airways (BEA) was the first scheduled passenger carrier to make an automatic landing on Heathrow Airport, with a de Havilland Trident aircraft.

Around 1970 new long-range wide-body airliners such as the Boeing 747, the Douglas DC-10 and the Lockheed L-1011 were introduced. These new airliners, powered by less noisy and less fuel consuming high-bypass-ratio engines, provided a further increase in the productivity and economics of the air transport system. They also introduced a significant new problem: the large wake vortex. The new wide-body airliners were all equipped with a reliable Automatic Landing System (ALS) allowing approach and landing on adequately (Category 3 ILS) equipped runways in conditions without any vertical visibility.

Furthermore the airliners were equipped with an Inertial Navigation System (INS) and a reliable VHF and HF voice communication system, allowing the reduction of the flight crew to two pilots and a flight engineer.

2.7 Digital avionics and Fly-by-Wire

In the 1980s new short-to-medium range airliners such as the Airbus A300/A310 and the Boeing 757/767 appeared. These new narrow-body and wide-body airliners are equipped with an Electronic Flight Instrument System (EFIS), a Flight Management System (FMS) and a Flight Warning Computer System (FWCS). In more detail the EFIS, FMS and FWCS provide the following functions:

- The EFIS Primary Flight Display (PFD) reduces the scanning cycle by a combined presentation of attitude, flight director, Instrument Landing System (ILS) deviation, flight mode annunciation, speed and altitude information on a monochrome Cathode Ray Tube (CRT) display.
- The EFIS Navigation Display (ND) provides integrated map, horizontal flight path, weather radar, heading and wind-vector information on a monochrome CRT display. This integration of information provides an enormous increase in the possibility to directly interpret all aspects of the navigation and avoidance of bad weather. Combined with the information from the Flight Management System, this ND presentation greatly increased the "positional awareness" of the pilot.
- The FMS provides integrated navigation and fuel management information as well as a host of performance and navigation information to the pilot. The FMS integrates the information of all available navigation sensors into an optimal position and wind vector. It computes the actual aircraft mass from the take-off mass and fuel burnt, and by using the aircraft and propulsion system performance data from its database can compute optimal 4-D flight trajectories, fuel remaining on destination, maximum endurance, etc. The FMS largely reduces the flight crew workload with respect to flight management and navigation.
- The FWCS provides alphanumeric and synoptic graphical system information, on two colour CRT displays. The systems status becomes more "natural" for the flight crew, by providing the systems information as schematics and using colours combined with alphanumeric quantitative information.

The Airbus A-310 Electronic Centralized Aircraft Monitoring (ECAM) system is an excellent example of how the flight crew's "aircraft systems awareness" can be improved, largely reducing the workload with respect to systems operation and system malfunction handling.

The "glass" cockpit of the Airbus A-310 and Boeing 757/767 is equipped with six colour CRT graphics displays for the EFIS and FWCS as well as two alphanumeric monochrome Control Display Units (CDUs) for the FMS. Apart from the CRTs, a number of electromechanical instruments are still used for the presentation of airspeed, altitude navigation and engine parameters. The introduction of the EFIS, FMS and FWCS allowed the elimination of the flight engineer from the flight deck. This provided a significant cost reduction for the operation of this type of airliner.

Around 1990, a long/medium-range aircraft with a revolutionary new digital flight control system appeared, no longer using mechanical links between the pilot's control yoke and the hydraulic actuators of the flight control surfaces. This Fly-by-Wire (FBW) technology allowed new flight control concepts and envelope-protection systems. Examples of these new FBW airliners are the Airbus



A320/330/340 and the Boeing 777. The engines of this new generation of airliners are controlled by Full Authority Digital Engine Control (FADEC) systems. In the cockpit, the colour CRTs in the A-320/330/340 and the colour Liquid Crystal Displays (LCDs) in the Boeing 777 have become larger in size. Only a very limited number of mechanical stand-by instruments are left to enable a safe continuation of flight in case all large screen electronic displays would fail.

3 Development of scheduled airline production, safety and environmental aspects from 1970 - 1995

3.1 Scheduled airline production

Between 1970 and 1995 the production as well as the safety record of the about 700 scheduled airlines of the 183 Contracting States of ICAO have increased continuously, as can be seen in table 1.

Table 1 Air transport growth [7]

Year	Number of jet airliners	Passenger Kilometres (Billion)	Tonne-Kilometres Freight (Billion)
1970	3,750	460	10
1980	6,250	1070	29
1990	9,300	1890	59
1994	11,710	2086	77

The contribution of the various Contracting States of ICAO to the total air transport of the world differs significantly, as can be seen in table 2.

Table 2 Contribution in Passenger-Kilometres and total Tonne-Kilometres of the scheduled airlines of ICAO's 12 largest RPK producing States

State	Passenger-kms (10 ⁹)	Total Tonne-kms (10 ⁹)
United States	820.0	96.7
United Kingdom	137.8	19.6
Japan	118.0	16.2
Russian Federation	83.8	8.5
France	67.5	11.3
Australia	63.7	7.8
Germany	56.9	11.2
China	51.4	5.5
Singapore	44.9	7.6
Canada	43.5	5.5
The Netherlands	42.9	7.4
Rep. of Korea	39.6	8.2

About 40% of the world's passenger-kilometres are produced by the USA alone. The United Kingdom, France, Germany and the Netherlands in combination contribute about 15% tot he world's total produced Passenger-Kilometres.

3.2 Scheduled airline safety

In table 3 the development of the safety level of the world's scheduled airlines is given. From this table it becomes clear that the number of fatalities per passenger-kilometer has significantly decreased, the yearly number of fatal accidents and fatalities as well as the fatal accidents per 100,000 flights has stabilized in the last decade.

Table 3 Scheduled airline safety (excl. CIS and PRC) 1970-1994 [7,8]

Safety statistics	1970-1979	1980-1989	1994
Fatal accidents	206	207	28
Pass. fatalities	8251	8700	941
Pass. fatalities per 10 ⁸ pass.-km	0.15	0.06	0.05
Fatal accidents per 10 ⁵ landings	0.29	0.17	0.16

As part of the traffic is produced by turbojet aircraft and part by turboprop aircraft, the relative safety levels, as shown in table 4, are also of interest.

Table 4 Safety of turboprop and turbojet airliners

Aircraft type	Percentage of traffic	Total Accidents	Fatalities
Turbojet	95	11	729
Turboprop	5	17	212
Total	100	28	941

One has to take into account that turboprop aircraft make relatively short flights with more take-offs and landings and operate a much larger percentage of the flight-time closer to the ground and in worse weather conditions than jet airliners.

The main causes of the fatal accidents and fatalities in 1994 are given in table 5. Note that most accidents have multiple contributing causes [7].



Table 5 Main fatal accident causes in 1994

Accident cause	Accidents (%)	Fatalities (%)
Aircrew error	65	68
Controlled Flight into Terrain	37	43
Weather	30	24
Loss of Control	14	34
Engine Failure / Fire	16	7
Structural / System Failure	11	13

The distribution of fatal accident causes for 1994 corresponds to the distribution of the causes in the last decade.

The analysis of the accidents caused by inadequate terrain separation, windshear and mid-air collisions have caused the USA and other countries to develop regulations and requirements with respect to additional warning systems. These warning systems have to serve as a "safety net", in addition to an adequate air traffic control system.

3.3 A safety net of Warning Systems

To assist the flight crew in its task of maintaining safe flight, a "safety net" of warning systems has been introduced.

* Ground Proximity Warning System (GPWS)

Controlled Flight Into Terrain (CFIT) is the primary cause of scheduled airline fatalities. From 1988 until 1992, 23 of the 64 fatal accidents were caused by CFIT, resulting in the loss of 1,577 lives [9]. From as early as 1975, US airliners carrying more than 30 passengers had to be equipped with a GPWS. A number of international airlines followed this US example. The GPWS processes radio altitude, pressure altitude, aircraft configuration and when available, ILS Glide Slope information, to provide aural and visual warnings, for example in case of approaching the terrain at a too high descent rate or in the wrong aircraft configuration. One of the problems with the present generation of GPWS is the number of "nuisance alerts". These nuisance alerts decrease the level of confidence of the flight crew in the GPWS. An inherent problem with GPWS is that it has no or very limited anticipation of approaching high ground.

Looking at the regions in which Controlled Flight Into Terrain (CFIT) accidents happened, one can see great differences.



Table 6 CFIT accident rates per million flights (1983 to 1992)

Area	Accident rate
North America	0.03
Asia/Pacific	1.00
Europe	0.45
Africa	2.40
Latin America/Caribbean	1.14
Middle East	0.00
Australia	0.00

A large number of the CFIT accidents happened during step-down non-precision approaches in reduced visibility conditions and in mountainous terrain where no adequate approach guidance and radar surveillance was available.

In the USA, Europe and Australia the infrastructure of nav aids, precision approach systems, radar surveillance systems as well as the use of GPWS, etc. is such that the number of CFIT accidents is very limited. In the USA the number of GPWS-equipped airliners is very large. Furthermore, a Minimum Safe Altitude Warning System (MSAWS) is used that, through comparison of the aircraft pressure altitude and local terrain elevation, can determine the terrain clearance and can alert the air traffic controller who in turn can instruct the pilot to take action. These two factors contribute to the fact that the CFIT accident rate in the USA is very low.

*** Windshear detection, warning and guidance system**

Worldwide windshear accidents caused 455 fatalities in the 1979 to 1990 period. In the US windshear is a major contributor to aircraft hull losses. After 1993 all US aircraft carrying more than 30 passengers have been equipped with a windshear detection, warning and guidance system.

Existing windshear detection warning and guidance systems compare INS ground speed with airspeed to detect windshear. Regrettably this type of systems can only provide warning and guidance 5-7 seconds after the aircraft encounters windshear.

*** Traffic Alert and Collision Avoidance System**

After 1993 all US aircraft that can carry more than 30 passengers have to be equipped with a Traffic Alert and Collision Avoidance System (TCAS). TCAS provides traffic information and collision avoidance guidance (vertically) based on the processing of transponder replies of other aircraft and the own aircraft flight-path vector. TCAS can be seen as the required additional element to make ATC fail safe. The problems with the present TCAS are that TCAS generates many alerts that have no operational relevance, that TCAS has no anticipation of the (ATC instructed) intentions of other aircraft (e.g. levelling-off after a climb or descent). Also the conflict resolution manoeuvres may cause new

conflicts. A near mid-air collision between a TCAS-2 equipped Alaska Airlines MD-80 and a TCAS-2 equipped United Airlines DC-10 near Seattle International airport clearly showed the potential danger of using TCAS in an ATC environment [10]. Reference 11 describes the technical and operational problems with the present generation of TCAS.

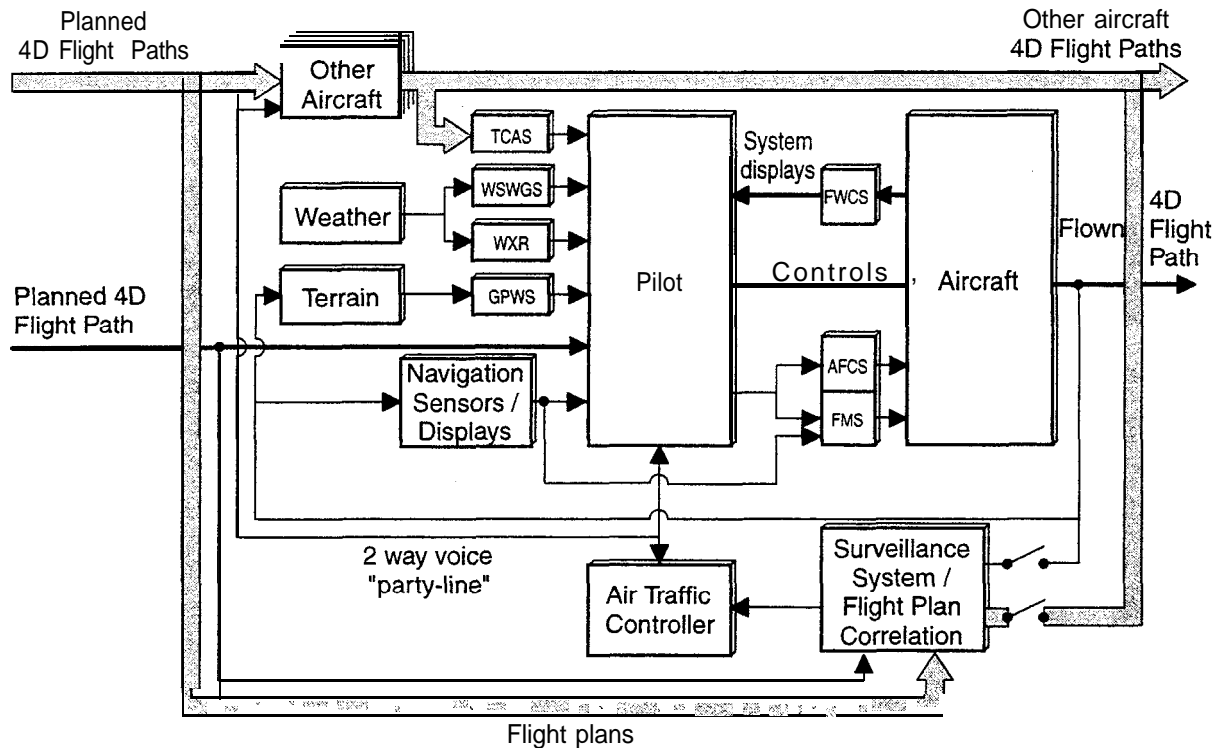

Fig. 3 The present-day Air Traffic Control loop

3.4 Present-day Air Traffic Control

In figure 3 the “control loop” block diagram of the present day airliner with all the “safety net” warning systems in the existing ATC environment is presented.

Radar is the main source of information for the surveillance of the air traffic in the important parts of a FIR. Where possible, Air Traffic Controllers communicate with the pilots by means of Very High Frequency (VHF) voice radio links.

Digital ATC computers combine flight plan data with (secondary) radar-transponder-derived identification and altitude information to provide an enhanced radar display, showing aircraft positions labelled with flight identification, altitude, assigned flight level, ground speed, etc. to the air traffic controller. Furthermore, algorithms are used for strategic planning and sometimes also for Short Term Conflict Alert (STCA) in the event that two aircraft are likely to come into conflict.

The Air Traffic Controller uses traffic information from flight plans, radar information and VHF Direction Finder (VDF) information to monitor the safe traffic flow. Through voice clearances the Air Traffic Controller can instruct the aircraft to maintain safe separations and to provide a safe sequencing of the aircraft for approach and landing. The planning process of the sequencing of the aircraft for approach and landing normally starts at the moment when the aircraft enter the FIR. Because a single

Air-Traffic Controller can handle maximally 15-20 aircraft simultaneously, the airspace within the FIR is divided into sectors. The sector Air Traffic Controller handles only the traffic within his or her sector on a "first come, first served" basis. The sector Air Traffic Controller finally hands-off the traffic to the controller in charge of the TMA traffic. He guides and sequences the aircraft by providing them so-called radar vectors towards the intercept points of the ILS for the approach to the runway. In the areas of the FIR where radar surveillance and VHF communication are available, separations of 3-5 NM can be used.

Over the oceans and other areas where radar surveillance is not possible, procedural ATC is used. This requires large separations (10 minutes flying time longitudinally- about 80 to 90 NM - and 60 NM laterally). At regular intervals a pilot provides a position report (PIREP) via the High Frequency two-way voice radio communication. To structure the traffic flow on these oceanic flights, the Organized Track System (OTS) was defined. The pilots fly their fixed-altitude routes, using the Inertial Navigation System supplemented by OMEGA Very Low Frequency (VLF) radio navigation updates.

3.5 Aircraft emissions and noise

Aircraft operations affect the environment through noise and emissions. While noise is mainly important near airports, emissions are important during the whole flight. Emissions are related to fuel consumption and to the quality of the combustion of the engines [12]. The prime objectives of airframe designers have been to increase the range and the efficiency by reducing the fuel consumption, through the reduction of aerodynamic drag and structure weight. Engine designers have provided propulsion systems with continuously improving efficiency, further contributing to increased range and efficiency.

Commercial aircraft operations consume more than 100 million tonnes of fuel per year. This contributes about 3% to the total world energy consumption. In term of energy used for transport, commercial aviation consumes about 13% [12]. Fuel consumption of commercial aircraft has reduced enormously over the last 25 years through the use of improved aerodynamics, reduced structural weight and increasingly more efficient engines. The Airbus A300-600 jet aircraft of today uses about 28% less fuel per seat than the original A300 of 1974. The Fokker 50 turboprop of 1987 consumes 31% less fuel per seat than its predecessor, the Fokker F27 MK500 of 1968 [12]. Also the emissions of smoke, hydro-carbons and carbon-monoxide have reduced considerably since 1970. In Table 7 the improvement in Specific Fuel Consumption (SFC) of the succeeding generations of jet engines with increasing bypass ratios are given.



Table 7 Reduction of fuel consumption

Year	Bypass Ratio	Relative SFC
1960	1	100
1970	< 3	82
1980	< 6	82
1985	< 12	50

Noise was the first environmental parameter introduced into aircraft certification by ICAO in 1969. Since then the limits set by legislation and certification have been tightened. The reduction of engine noise contributed most to the dramatic reduction of the overall aircraft noise.

Figure 4 gives an overview of the progress of the aircraft noise reduction since the introduction of the jet airliners.

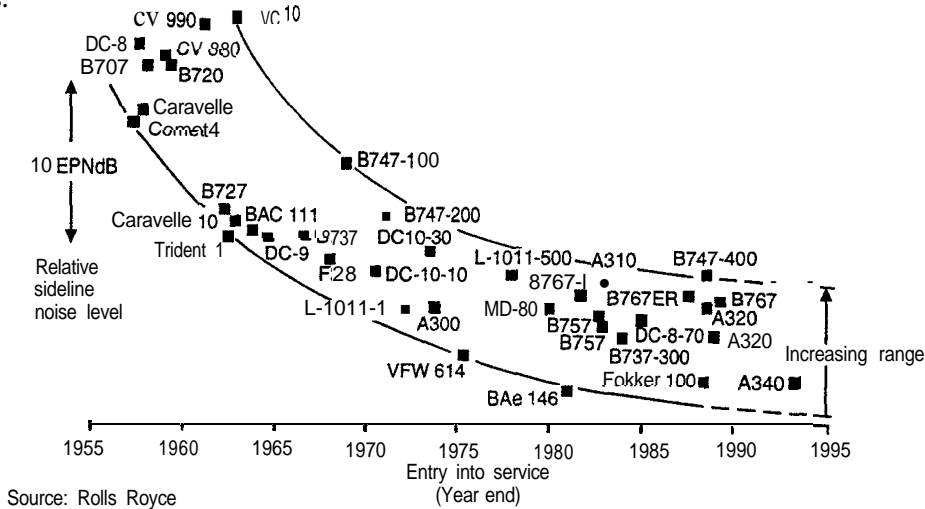

Fig. 4 Progress of aircraft noise control

The impact of the noise reduction achieved is best demonstrated by a comparison of the noise footprint of aircraft of two consecutive generations, both carrying the same number of passengers. The take-off footprint area of the A320 (1990) compared to that of the Boeing 727 (1970) shows a reduction of the 85dB(A) contour from 14.25 km² to 1.55 km² or a reduction by a factor of 9. In the turboprop segment the take off noise footprint area of the Fokker 50 (1987) compared to the Fokker F27 MK500 (1968) shows a reduction of the 80dB(A) contour from 3.77 km² to 0.84 km² or reduction by a factor of 4.5. A further reduction of the aircraft noise perceived by the population on the ground was found in special take-off and landing procedures and control of land use around airports. Around most airports Standard Instrument Departures (SIDs) and Standard Arrival Routes (STARs) are used to minimize the noise to the population. Compliance with the SIDs and STARs is monitored by radar recording systems in combination with noise monitoring systems on the ground.

4 Air transport growth in the next decades, problems and solutions

4.1 Forecasted growth

Air transport has evolved into a very safe, reliable and economic means of transport through the interaction of the

- Airline industry.
- Aeronautical industry.
- Airports.
- Air Traffic Control Organization and
- Civil Aviation Authorities.

In figure 5 the interrelations are given.

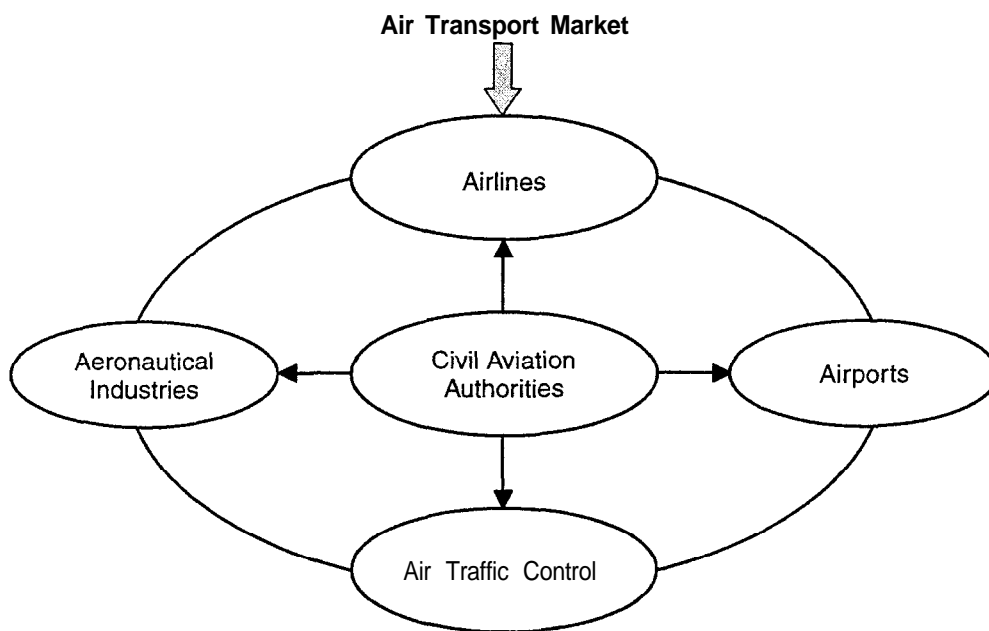

Fig. 5 Air transport elements

To accommodate the expected air transport needs, the airlines determine the number and size of the airliners required. The airports have to provide an adequate runway, taxiway, apron and terminal capacity to accommodate the traffic. The aeronautical industry has to provide the aircraft.

The Air Traffic Control organizations have to control the traffic in the air, to and from the airports and on the ground. And finally the Civil Aviation Authorities have to set the safety and environmental standards that all other elements have to comply with.

The major aircraft manufacturers forecast an average annual air transport growth of about 5% per year for the next two decades [13]. Worldwide this means a growth of a factor of three in 20 years. This growth will be different in the various regions. In North America and Europe the growth will be 3-4%. In the Pacific region the growth will be over 7%. To accommodate this growth the number of jet aircraft in the world's commercial airline fleet will have to grow to over 20,000 aircraft.

Also taking into account replacements of retired airliners, over 15,000 new aircraft with a total value of over 1000 billion US dollars will have to be produced. About one third will go to the airlines of North America, about 28% to European Airlines, about 26% to the airlines of the Asia Pacific Region and the remaining 13% to the airlines of Africa, Latin America and the Middle East.

The average size of the airlines will grow from about 180 seats in 1995 to 246 seats in 2014. The percentage of wide-body aircraft will grow from the present 28% to 40% in 2014.

4.2 New generation of airliners

The future generation of airliners will have to be designed to:

- Reduce acquisition cost.
- Increase dispatch reliability.
- Reduce noise and emission.
- Operate worldwide in all-weather operations.

The airframe industry has targeted its research and development efforts towards:

- Reduction of fuel consumption,
 - * Reduction in aerodynamic drag (Computational Fluid Dynamics (CFD), laminar flow) of 15%,
 - * Reduction in structural weight (composites) of 20%,
- Reduction of design and manufacturing cost of 20%,
 - * Computer Aided Design and Manufacturing (CAD/CAM),
 - * Economy of scale/large series,
- Reduction of maintenance cost of 40%,
 - * Reliable, damage-tolerant construction,
 - * Improved diagnostic facilities for airframe, engines, systems and avionics,
- Reduction of noise and vibration,
- Reduction of the use of environmentally unfriendly materials [14].

The engine industry has targeted its research and development efforts towards:

- Reduction of Specific Fuel Consumption (SFC) of 30%,
- Reduction of engine weight of 20%,
- Reduction of noise of 5-6 dB,
- Reduction of NOx emissions of 90%.



4.3 Improved safety

4.3.1 Necessity and strategy to improve air transport safety

The safety level of the world's scheduled airlines has stabilized in the last decade at about 0.16 fatal accidents per 10^5 flights and 0.05 fatalities per 10^8 passenger kilometres [7]. This means that with the anticipated growth of air transport the annual number of hull losses and fatalities will increase linearly with the increased traffic.

Because of the high public visibility of airline accidents it is clear that actions will have to be taken to further increase the safety level of scheduled air traffic. The governments have the ultimate responsibility for the provision of regulations and standards for aircraft design and manufacturing, pilot and air traffic controller selection and training, etc. Most nations use the ICAO-provided guidelines to develop national airworthiness regulations, operational procedures, etc. Experience from incidents and accidents is used to improve governmental regulations where possible. Much effort is nowadays directed towards the international standardisation of these regulations. In Europe a number of nations have decided to provide through the Joint Aviation Authorities (JAA) uniform standards and regulations.

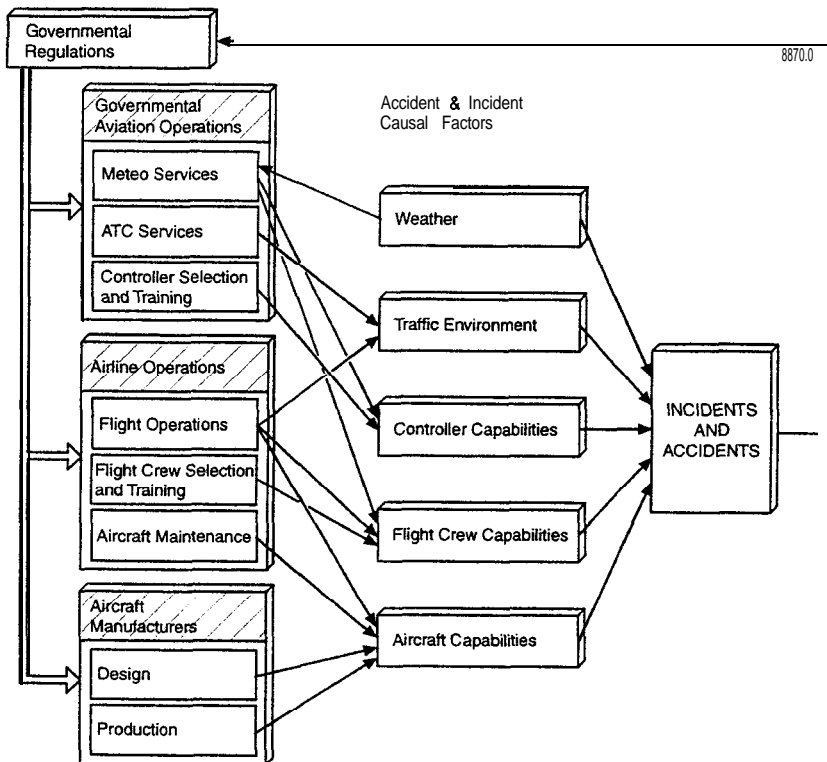

Fig. 6 The aviation safety control loop



In figure 6 the various causal factors for aviation accidents provide the valuable inputs for the modification of governmental regulations for the aircraft manufacturers, governmental aviation operations and airline operations.

Boeing executed an overview of the "lessons learned" from 232 commercial jet aircraft accidents (leading to 5,713 fatalities) over a 10-year period (1982-1991) and provided recommendations for Accident Prevention Strategies [15]. For each accident the sequence of events leading to the accident was established. Events were grouped using 37 categories of Accident Prevention Strategies. An Accident Prevention Strategy is defined as an action which, had it been utilized, would have broken the chain of events and prevented the accidents. The number of strategies identified for a given accident varied from only one (in 39 accidents) to 20 (in one accident) with an average of just under 4 strategies per accident. Among the 232 accidents there were 193 in which two or more opportunities existed to stop the progression of events and thus prevent the accident.

The four most important Accident Prevention Strategies had to do with:

- Flying-pilot adherence to procedures.
- Other operational procedural considerations.
- Embedded piloting skills.
- Non-flying pilot adherence to procedures.

This means that a great improvement still can be expected from better procedures and training as well as from improved warning systems and Man-Machine Interface Systems and Human Factors Research.

Apart from the feedback of the "lessons-learned" from accidents it will be increasingly important to learn from incidents and other operational experience. One way is the analysis of the data on flight-data (and quick-access) recorders. Another is from the analysis of data from the various confidential reporting systems available worldwide. The main problems with the use of these operational data are the privacy of flight crews and the commercial sensitivity of these data. An adequate protection scheme to eliminate these problems is absolutely essential.

4.3.2 Improved warning systems

Although present-day airliners are equipped with a number of warning systems, many suffer from limitations with respect to "forward-looking capabilities". Further improvements can contribute to an increase of flight safety.

*** Improved Ground Proximity Warning System (GPWS)**

As described in 3.3 many airliners are already equipped with GPWS. The introduction of GPWS provided a significant reduction in the number of CFIT accidents. The number of CFIT accidents should be further reduced by providing all aircraft with GPWS as soon as possible. For the avoidance of terrain, GPWS uses the combination of a radio altimeter and a pressure altimeter. These sensors can



only identify limited gradients in terrain altitude. Because of the lack of forward-looking capability of the present generation of GPWS, CFIT accidents against steep mountains will continue to happen if no special measures are taken. So, to warn for steep gradients an improved GPWS will have to be developed. A possibility is to use an INS-derived flight path vector and digital terrain database. Allied Signal is developing such a digital terrain-data based GPWS.

*** Improved Windshear Detection and Warning System**

Present-day windshear warning systems can only detect the existence of windshear after the aircraft has entered the windshear. In a number of cases this proved to be too late. A significant improvement can be obtained by using forward-looking sensors to detect a windshear in front of the aircraft. Experiments have shown that forward-looking windshear sensors, based on infra red, laser or Millimetre Wave (MMW) radar, are feasible [16].

*** Improved Traffic Alert and Collision Avoidance (TCAS)**

More and more airliners are being equipped with TCAS. Because TCAS has no information on the intentions of conflicting aircraft, occasionally unnecessary warnings are generated. By combining FMS/AFCS flight-path intentions from the own aircraft and from the conflicting aircraft (provided by datalink) these unnecessary warnings could be suppressed. This will eliminate unnecessary and dangerous evasive actions that may result in new conflicts with other aircraft. In TCAS4 this datalink capability will be implemented. Experience with military developments as the Joint Tactical Information Distribution System (JTIDS) and several civil datalink/networking experiments show a great potential.

*** Ground Movement Collision Warning System**

Accidents due to incorrect taxiing aircraft, usually in reduced visibility conditions, are a major cause of fatal accidents on the ground. An airport map display indicating the cleared taxi route and the aircraft position on it may provide a significant safety improvement.

*** Improved AFCS Mode Annunciation**

A great number of accidents and incidents are caused by the mis-interpretation of the selected or evolved AFCS mode and related trim settings. Examples are the Air Inter A-320 CFIT accident near Strassbourg and the China Airlines A-300 accident near Nagoya. New avionics will have to be developed to provide a more transparent presentation of the AFCS actual and developing future modes to improve the flight crew's "autoflight system mode awareness". Better AFCS mode annunciation warning systems in combination with a fail-safe en-route AFCS (use of two instead of one AFCS channel) will greatly increase flight safety.



*** Improved ice-detection and warning system**

Icing remains an important cause of aircraft accidents. Apart from improving the ground-icing safety practices the development and installation of ice detectors on the wings may be of great importance to increase the flight crew's awareness of icing.

*** Improved warning system for volcanic eruptions**

Although till today no fatal accidents have occurred due to volcanic eruptions, the incidents that have happened give cause for considerable concern.

- In 1982 the eruption of Mount Galunggung caused an all-engine flame out to a British Airways Boeing 747 and to a Singapore Airlines Boeing 747 [17].
- In 1987 the eruption of Mount Redoubt in Alaska nearly brought down a KLM 747-400 and severely disrupted aviation operations in Alaska [17].
- In 1991 14 airliners flew through the ash clouds of the eruption of Mount Pinatubo at the Philippines. Ten aircraft engines had to be removed [17].
- In 1995 the eruption of Mount Klyuchevskoi at the Kamchatkan Peninsula disrupted air traffic for 60 hours. The effective early warning system called KVERT (Kamchatka Volcanic Eruption Response Team) had provided a warning to the pilots about 27 minutes after the eruption [18].

In the South Pacific and South East Asia area, about 130 active volcanoes regularly erupt. Along the North Pacific Routes, about 100 active volcanoes provide 5-6 eruptions per year [18, 19]. The eruptions can cause dangerous dust clouds in a very short time. The Mount Pinatubo eruption generated a dust cloud that reached 30,000 ft in about 5 minutes and eventually reached 100,000 ft altitude. The dust cloud caused a closure of the airspace over the Philippines, over a wide area of the South Chinese Sea as far as 1000 NM from the volcano [17]. The development of an effective, internationally-organized, quick reaction warning system for volcanic eruptions will be essential to prevent fatal accidents.

4.3.3 Synthetic and Enhanced Terrain Vision

The introduction of an adequate ATC and precision approach system infrastructure, the further development of procedures and training concepts and the introduction of an improved "safety net" for collision with terrain and other aircraft and windshear warning will increase the safety level of future air transport. However, particular attention is also necessary towards the Man-Machine Interface (MMI). This improved MMI will have to improve pilot's situational awareness [20] and reactions to the improved warnings. A potentially very powerful way will be through Synthetic and Enhanced Outside Vision. Pilots learn to fly in VMC. Through outside vision the pilot finds his way on the airport, determines the correct take-off path along the runway, controls the correct attitude during climb with respect to the visual horizon, navigates, avoids collision with terrain, descends, approaches and lands. The ideal cockpit display should emulate as far as possible the VMC outside vision, complemented with all the other items that the pilot can see in Visual Meteorological Conditions [21].

The first step towards this ideal situation is the use of Synthetic and Enhanced Terrain Vision. By using a digital terrain database in combination with a radio altimeter, GPS satellite position and IRS position, velocity and attitude data, a very accurate and robust position and attitude sensor system can be provided. By means of the 3D digital terrain database and the position and attitude information an outside visual image of the terrain can be generated and displayed on a Head-Up-Display (HUD). Figure 7 shows a block diagram of such a Synthetic Terrain Vision System (STVS).

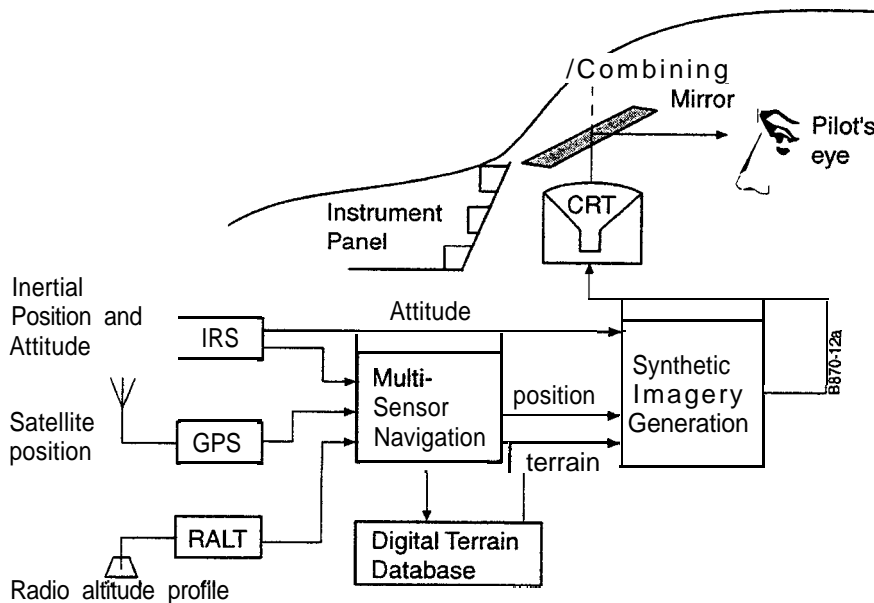

Fig. 7 Synthetic Terrain Vision System

For military applications, significant research and development activities have taken place towards Synthetic Vision. In reference 22 the development of a military STVS based on a digital terrain database is described. When in case of a GPWS warning the pilot can directly see the cause of the warning as a synthetic terrain image through a Head-Up Display (HUD), a more direct response can be expected than with the present GPWS. It is clear that the reliability and integrity of such a STVS for civil applications will have to be adequately high.

A similar improvement of pilot awareness during taxiing, take-off, approach and landing is the application of Enhanced Terrain Vision. By providing fused imagery of Low-Light-Level Television (LLTV), Imaging Infra-Red (IIR) and Millimetre Wave (MMW) radar and presenting this information on a HUD the pilot will be able to operate safely in reduced visibility conditions. An Enhanced Terrain Vision System (ETVS) will provide the pilot with a better detection of other aircraft and vehicles during taxiing and help to prevent runway incursions. In figure 8 the block diagram of an Enhanced Terrain Vision System (ETVS) is presented.

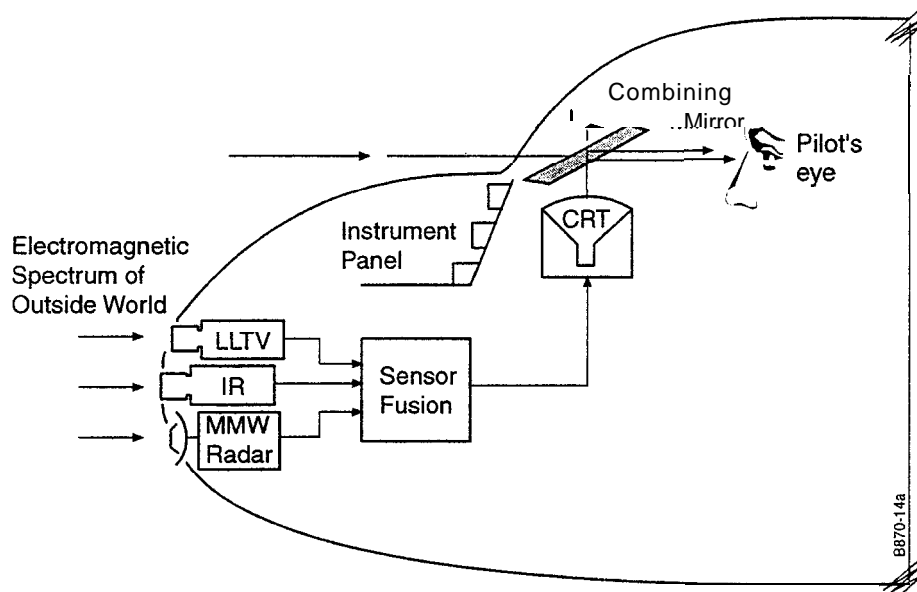

Fig. 8 Enhanced Terrain Vision System

The ETVS may also provide the possibility to execute Category 2 and Category 3a approaches with up to 700 ft. Runway Visual Range (RVR) and 50 ft. Decision Height (DH) on a Category 1 Instrument Landing System (ILS) and to continue the final approach and landing visually [23]. The avionics industry, FAA, NASA and the US Department of Defense have executed several flight-test programmes to demonstrate aircraft sensor and system performance. The flight tests encompassed over 150 approaches to 10 different airports. The sensors used were 35 and 94 GHz MMW radar and 3-5 μm as well as 8-12 μm Forward Looking Infra Red (FLIR) sensors. The sensors provided a real-time image of the runway which was combined with alphanumeric and displayed on a HUD [24]. The FLIR provided an excellent image of the runway and its surroundings in clear weather and in haze. The FLIR image quality was, however, significantly degraded in clouds, fog and rain. Pilots had no difficulty using the MMW image on the HUD, combined with alphanumeric symbology to make low workload approaches, landings and take-offs in simulated zero-ceiling, zero-visibility conditions and in actual instrument meteorological conditions down to 700 ft. visibility. The pilots had been trained in flight simulators and during progressively more challenging conditions.

It may be expected that by optimally “fusing” the MMW radar and FLIR images a best image can be provided for the existing meteorological conditions. In reference 25 the promising results of such a sensor fusion programme at NASA-Ames Research Center are described. A good overview of state of the art of Synthetic and Enhanced Terrain Vision is given in reference 26.

Boeing and United Airlines have started to develop an Enhanced Situational Awareness System (ESAS), using IIR, MMW radar and sharpened X-band radar as sensors and a HUD for presentation to improve safety as well as to enable reduced visibility approach and landing [27,28]. The potential advantages of ETVS are clearly indicated by the approval of the FAA to Maryland Advanced Development Laboratory to use an EVS (consisting of a forward-looking IIR sensor and a HUD) in Category 3a minima (50 ft DH and 700 ft. RVR) on a Category 1 ILS equipped runway for its Cessna 402B twin-engine aircraft [29].

The provision of synthetic and enhanced “outside vision” to the pilot in combination with an adequate Autoflight system will increase the pilot’s “terrain awareness” and will thus allow the pilot to avoid collision with terrain as well as perform “visual” operations in reduced visibility conditions, thus contributing to safety as well as to operational flexibility.

4.3.4 Integrated Outside Vision System

The developments towards Synthetic and Enhanced Terrain Vision System can evolve into a complete Integrated Outside Vision System (IOVS). In figure 9 the block diagram of such a potential future overall Outside Vision System is given. Powerful digital computers will provide the Synthetic Visual Terrain information based on satellite/inertial position and attitude information and prestored digital terrain and airport information. With LLTV, IIR and MMW radar the real terrain can be sensed and the enhanced terrain vision can be superimposed on the synthetic terrain presentation. Through Weather Radar (WXR) and forward-looking Windshear and Wake-vortex detection systems, a weather state vision can be added. The Flight Management Computer can provide the optimal flight path as a 4D Tunnel-in-the-sky.

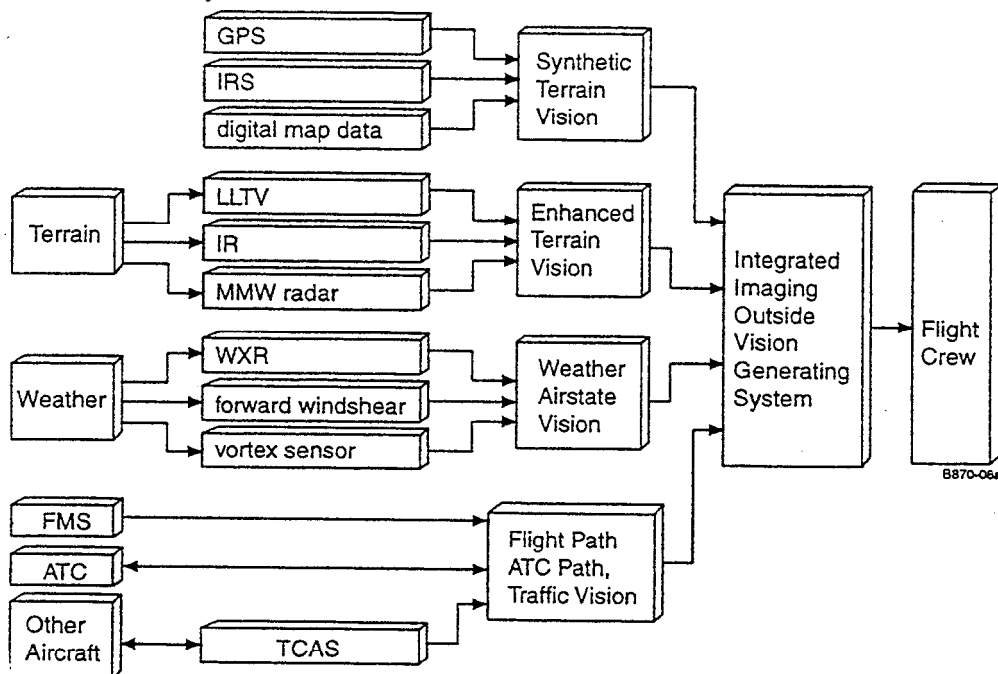

Fig. 9 Integrated Outside Vision System

When ATC is available the FMS-generated four-dimensional flight path could be replaced by an FMS-ATC negotiated near-optimal Tunnel-in-the-sky. A digital datalink is to be used for this FMS-ATC communication.

The application of digital datalinks can also provide information to the pilot on weather conditions, volcanic eruptions, clear air turbulence, etc. detected by different ground-borne systems as well as allow ATC computers to monitor the aircraft state-vector provided by the aircraft systems for additional vigilance.

Finally TCAS could be used to watch for intruding aircraft especially when no ATC is available. The position of the intruder could be indicated in the synthetic Integrated Outside Vision System presentation.

Before these new Integrated Outside Vision System will be available a large number of research areas will have to be further explored such as:

- Propagation properties of the atmosphere for the various sensors.
- Dynamics of the various sensors.
- Extraction of the appropriate cues from the sensor data.
- Correct fusion of the sensor information.
- Correct fusion of synthetic information and (enhanced) sensor information.
- Human perception of visual and motion cues.
- Optimal presentation of the integrated outside vision information on Head-Down Displays, Head-Up Displays or Head Mounted Displays in combination with the directly visible information outside the cockpit.
- Required field-of-view, head tracking and/or eye tracking dynamics.
- Use of colour.
- Pilot confidence in and appreciation of the reality of the Synthetic/Enhanced imagery.

It can be expected that the sensor and display technology developed in military Research and Development (R&D) programmes will become available for civil applications for an acceptable price. Furthermore, it can be expected that the development of low-cost, high-performance computer technology will continue. Finally, it can be expected that the regulatory Civil Aviation Authorities will eventually prescribe the use of these technologies in the overall view of improving air-transport safety. The airlines will have to weigh the costs of the installation of the improved "safety-net equipment" as well as the Synthetic and Enhanced Terrain Vision Systems in combination with the advanced datalink-controlled FMS/AFCS/Autoland versus the potential operational and cost benefits of safe operations towards airports with a limited infrastructure, improved time-schedule reliability and improved safety record.



4.4 Improving the capacity of the airspace by integration and by the use of satellite-based Communication, Navigation and Surveillance

4.4.1 Harmonisation and integration of European ATC

In Europe for the next 25 years an average growth of 3.8% per year is forecasted, resulting in an overall growth of 2.5 in 2020 compared to 1995 traffic levels. The European Air Traffic Management System (EATMS) of 2020 will have to cope with a maximum of 5800 IFR aircraft movements per hour within the European Civil Aviation Conference (ECAC) Countries [30]. The punctuality will have to improve in such a way that 95% of all IFR departures will be ready to depart within 15 minutes of the scheduled departure time. In Europe approximately 80% of the jet aircraft are used for short to medium haul services. The average (IFR) flight duration in the ECAC area is about 1.3 hours and the average route length is only 475 NM. About 46% of the flight distance is in climb and descent phase, resulting in a climb/descent zone around each airport with a radius of about 120 NM.

To enable the growth of air traffic, in the next decades great improvements in the ATC as well as in the airport infrastructure will have to take place.

In 1989 the Association of European Airlines (AEA) published a report "Air Traffic Control in Europe" [31] in which they indicated that in the period of 1980-1988 more than 15% of the European flights suffered a delay of more than 15 minutes due to deficiencies in the infrastructure. The AEA compared the airspace of the, at that time, 22 ECAC States with the US (table 8).

Table 8 ATC in the ECAC-area and in the US

	ECAC	US
ATC Centres	42	20
Airspace (km ²)	4,643	7,828 ¹⁾
Number of Controllers	9,400	14,300
Total A/C hours (10 ³)	5,500	23,000

The AEA made a strong recommendation to the governments to improve this situation to accommodate the forecasted growth.

In October 1988 the ECAC Air Transport Ministers had already decided to establish a Central Flow Management Unit (CFMU) to be operational in 1993. The CFMU had to make the best use of the available airspace capacity. In April 1990 the ECAC Air Transport Ministers discussed a strategy to harmonize and integrate the European Air Traffic Control Structure [32]. This discussion resulted in

¹⁾ Excl. Alaska and Hawaiï



the establishment of the European Air Traffic Control Harmonization and Integration Programme (EATCHIP).

EATCHIP had the following objectives:

- The air traffic services route network and airspace structure is to be optimized, by a widespread application of area navigation from 1993 onwards.
- Comprehensive radar coverage is to be completed throughout the ECAC area by 1995.
- En-route radar separation of 5 NM is to be applied throughout high density areas by 1995 at the latest. Elsewhere, en-route radar separation of 10 NM is to be applied.
- Air-Traffic-Control Systems are to be progressively integrated after being harmonized in high density areas by 1995 at the latest and elsewhere not later than 1998.
- Automatic data communication between Air-Traffic-Control centres is to be completed by 1998 at the latest.
- Mode-S air/ground datalink is to be operational in central area from 1998 onwards.

The EATCHIP objectives are realized and results are becoming visible [33]. The European ATC delays have been halved between 1990 and 1995, despite an annual traffic growth of 5%. EATCHIP has achieved comprehensive radar coverage for en-route surveillance in all the Area Control Centres (ACCs) in Europe's high air-traffic-density areas and about 65% of ACCs in other areas. In 1990 only 40% coverage existed in the lower-density areas. As a result of EATCHIP reduced radar-separation distances of 5 NM are now applicable in 76% of high density areas compared to 21% in 1990.

European airspace has been restructured to eliminate the exclusive use of areas by the military. New communication systems exchange flight plans and ATC data between centres in 90% of the ACCs, compared to 37% in 1990. The Brussels Central Flow Management Unit (CFMU) is to become fully operational in April 1996.

To further improve the surveillance quality in the ECAC area, an ATC Radar and Tracker Server (ARTAS) system is being developed. ARTAS creates 4D tracks that can be used for an improved conflict detection paving the way for increased capacity [34].

Although the results of EATCHIP are very positive until now, it is still based on conventional radar surveillance, VHF voice communication between pilots and ATC-controllers and conventional VOR/DME en-route nav aids and ILS for approach and landing. To accommodate an increase of air traffic with a factor of 2-3 with an improving level of safety and a minimum load to the environment, new technologies and integrated systems will be necessary.

4.4.2 Satellite-based Communication, Navigation and Surveillance

Only a limited area of the world is covered by radar surveillance. For all the other areas, large separations are used, resulting in longer flying times, higher costs, higher fuel burn and more emissions. Satellite navigation and communication (GPS, Glonass and Inmarsat) allow aircraft to determine their position very accurately and to transmit this position in combination with other



important data (altitude, speed, heading, aircraft status, etc.) to ATC. This Automatic Dependent Surveillance (ADS) concept allows a pseudo-radar surveillance and the associated reduced separations and optimal routing. Tests with the ICAO requirements compliant ADS systems are taking place in Europe using British Airways and KLM Boeing 747s and Air France and Lufthansa Airbus A340s. In the Pacific area also extended tests are executed.

Starting in 1996 over the Pacific Ocean and in 1998 over the Atlantic Ocean aircraft position reports will be automatically sent to the appropriate oceanic ATC facility via a communication satellite.

In 1997 Tahiti will start operating a satellite-based oceanic ATC system. The Tahiti ATC system will become one of the main components of the South Pacific Future Air Navigation System (FANS) and cover an area bigger than Europe [35].

It has been estimated that an airliner can save an average of \$200,000 per year if it is solely used for flights over the Pacific. For airliners solely flying over the Atlantic savings of about \$500,000 per year have been estimated. These savings are in fuel not consumed and shorter flying times [36].

Emerging nations with an expanding air traffic will have to evaluate the cost-effectiveness of establishing a surveillance system based on primary and secondary radar versus the use of satellite-based ADS. One of the important nations testing satellite-based Air Traffic Management (ATM) infrastructure is China [37].

4.5 Increasing the capacity of airports and reducing noise and emissions

4.5.1 General

Although the integration and harmonization of the European ATC system, including the Central Flow Management Unit (CFMU), and the introduction of ADS over the Pacific and Atlantic Oceans will increase the capacity and efficiency of the available airspace, the real problems will come from the airport capacity and ATM capacity. In September 21, 1995, the Federal Aviation Administrator, David Hinson, made a speech to the Wings Club in New York City in which he stated: *"Airport capacity is about to become one of our most important concerns, second only to safety"*. According to Hinson, the 50 busiest airports in the US handle 81% of all the US air traffic. Twenty three of these airports experience more than 20,000 hours of delay a year. At Chicago 195's O'Hare airport delays have exceeded 100,000 hours every year for the last five years.

When the US aviation forecasts materialize in the year 2020, about 2.75 million people per day are expected to travel by airline in the US. An increase in the number of airports will be very difficult to realize, because of the high costs and decreasing public acceptance.

In the period from 1965 to 1995 only three new airports were built in the USA, Dulles, Dallas and Denver. And the cost of new airports becomes extreme. The new airport of Munich, Germany,



costed about \$7 billion and Japan’s Kansai “Blue Water” airport costed about \$15 billion [38]. Even if the money could be found to build new airports, Hinson wondered if the collective will exists to build them.

In Europe a similar lack of future airport growth potential exists. When the forecasted growth of 3.8% annually will become reality, a significant growth in the capacity of the existing airports will be necessary. In table 9 the resulting peak IFR departures and arrivals are given for 1995, 2005 and 2020 for the four most busy airport areas in Europe when the 3.8% growth is realized [30]. The only solution to the capacity problem will therefore be to increase the capacity of already existing airports [38].

Table 9 Air Traffic growth around the major European airports

Terminal Area	Peak IFR Departures and Arrivals per hour		
	1995	2005	2020
London ¹	150	220	380
Paris ²	120	170	300
Frankfurt	75	110	190
Amsterdam	100	150	250

1 Stansted, Gatwick and Heathrow
2 Charles de Gaulle and Orly

The effective capacity of an airport depends on a number of factors.

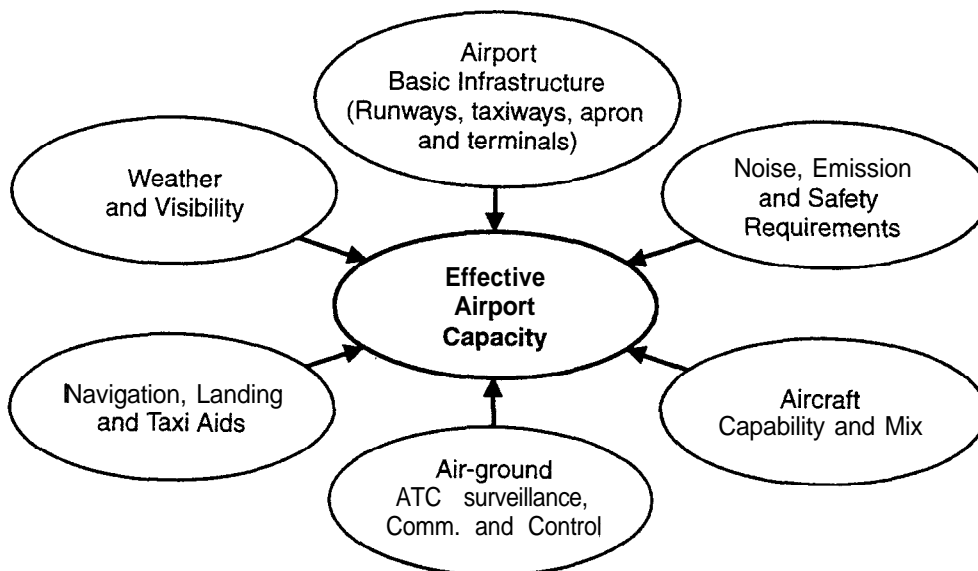

Fig. 10 Airport capacity determining factors

In figure 10 the various airport-capacity determining factors are presented.

- The first factor is the available airport basic infrastructure consisting of the number of (independent) runways, high-speed turn-offs, taxiways, apron capacity, number of gates, etc.
- The second important factor is the predominant weather and visibility conditions. Adverse weather and visibility conditions as thunderstorms, snowstorms, windshear and fog can severely limit the operational availability of the existing airport basic infra-structure.
- The third factor is the availability of all-weather navigation, approach and landing and taxi aids that can allow the aircraft to approach the airport, land and taxi to the gate in all visibility conditions.
- The fourth important factor is the capability of Air Traffic Control to control and direct all aircraft approaching the airport, landing, taxiing and taking-off in a safe and efficient way. This relates to the accuracy and update frequency of the surveillance systems, the availability of voice and data communication, control and display systems, etc.
- The fifth factor concerns the capacity of the airliners to approach, land and taxi as well as to take-off in all weather and visibility conditions. Furthermore, because the aircraft have to be separated according to their wake-vortex generation and sensitivity also the mix of various weight classes of aircraft will influence the capacity of the runways.
- The sixth factor concerns the noise, emission and safety requirements. An increasing number of airports is confronted with limits on the noise generated towards the population, the emission of NO_x and the external safety. These noise, emission and safety requirements will provide important limits to the capacity of airports. In the Netherlands, for example, noise limits have been set since 1980. The yearly noise hindrance is calculated in so-called Kosten Units (KEs). The Kosten Unit takes into account the maximum noise level in dB experienced at a certain location during the aircraft passage as well as the time-of-day this noise was generated.

Since a long time the 35-KE zone around Schiphol Airport is the established standard. The aim is to reduce the number of houses within this 35-KE zone to as few as possible. From 1979 to 1995 the number of houses within this zone has been reduced from 42,000 to 17,000. The Netherlands Government has set stringent limits to the growth of Schiphol Airport. The maximum number of passengers to be handled at Schiphol Airport is limited at 44 million. The number of houses within the 35-KE zone has to be reduced to 10,000 in 2003.

Furthermore, taking the year 1990 as a reference, the air and noise pollution as well as the risk to the population on the ground ("external risk") may not increase.

NLR developed a comprehensive method to assess the external risk or "third party risk" around airports. For third party risk two dedicated measures of risk are used:

- * individual risk: the probability (per year) that a person permanently residing at a particular location in the area around the airport is killed as a direct consequence of a single aircraft accident;
- * societal risk: the probability (per year) that more than N people are killed as a direct consequence of a single aircraft accident.



The calculation of the third party risk is based on three main elements:

- a. Probability of an aircraft accident in the area around an airport

This probability depends on the probability of an aircraft accident per aircraft movement and the number of aircraft movements per year. NLR developed a large database of relevant accidents to determine the relevant probability per movement.

- b. Accident location probability model

The accident location probability is based on historical data on accident locations. The distribution of the accident locations relative to arrival and departures routes is modelled through two-dimensional statistical functions. By combining the accident location probability model with the accident probability a local probability of an accident can be calculated for every location in the area around the airport.

- c. The accident consequence model

This model defines the lethal effect of an accident, depending on the aircraft and the local type of terrain and obstacles.

By combining the three main elements the individual risk and societal risk can be calculated. NLR used this method to assist Schiphol Airport to determine the best location for its new fifth runway.

Assuming that only a very limited possibility exists to increase the number of airports and runways and that the environmental and safety requirements will only increase, all possible efforts will have to be directed to maximize the capacity of the existing airspace and airports by introducing new systems and procedures.

In the next sections some new developments will be described that may improve the capacity of airports in all-weather conditions as well as reduce external noise and emissions.

They relate to:

- Precision approach and landing systems.
- Precision radar surveillance systems.
- Optimal sequencing of approach aircraft.
- Reduction of fuel consumption, emission and external noise through Continuous Descent Approaches.

4.5.2 Precision approach and landing systems

The weather conditions in the US and in Europe are quite different. In the US heavy thunderstorms, windshear and icing are the greatest dangers. In Europe low-visibility conditions are limiting the air traffic.

In Europe more than 90% of the world's Category 3 approaches and landings take place. At present more than 90% of the aircraft flying into Heathrow, Frankfurt, Charles de Gaulle or Amsterdam can



operate under Category 2 and 60% under Category 3 conditions. These low-visibility approaches and landings are made possible by the single-approach-path Instrument Landing System (ILS).

The difference in operating requirements are reflected by the distribution of Category 2 and Category 3 ILS configurations over the world.

According to Jeppesen [39] the distribution of Category 2 and Category 3 ILS configurations over the US, ECAC area and the rest of the world is as in table 11.

Table 11 Distribution of Category 2/3 ILS airports and runways

Area	Category 2		Category 3	
	Airports	Runways	Airports	Runways
US	40	41	38	48
ECAC	30	41	54	81
Rest World	38	44	5	5
Total	108	126	97	134

ILS however suffers from multipath problems that limit its accuracy. Dynamic multipath problems are caused by aircraft movements in the ILS sensitive areas. Static multipath problems are caused by buildings near the runways. The multipath effects from hangars, buildings and taxiing and departing aircraft result in drastic reduction in runway capacity in reduced visibility conditions. Under Category 3b conditions the runway capacity at Heathrow airport reduces from around 40 landings per hour (in good visibility) to only 15 [40]. Finally several European ILS configurations have been downgraded from Category 3b to 3a and 2 due to interference from commercial FM radio stations on nearby VHF frequencies. Alternatives to ILS to guarantee the Category 3b approach capability are required for airports and runways suffering from ILS multipath and/or commercial FM station interference.

In the US, with its less severe low-visibility conditions, the Federal Aviation Administration (FAA) is aiming at the introduction of the satellite navigation system GPS as a "primary means of navigation". To allow GPS in this role it has to meet the criteria of signal integrity, availability and accuracy. To meet the requirements for Category 1 approaches, in August 1995 the FAA awarded Wilcox Electric Inc. a six year \$475 million contract to "develop and build the Wide Area Augmentation System (WAAS)". WAAS will encompass 35 ground reference stations across the US, Alaska, Hawaiï and Puerto Rico that will be used to determine any error in the GPS signal [41]. The WAAS master stations calculate the corrections and send these to geostationary communication satellites that will broadcast the correction signals in a GPS format to all GPS receivers. The fully operational GPS-WAAS configuration is planned to be available in 2001 as a primary means of navigation for all phases of flight as well as for Category 1 precision approaches to most of the 8000 airports in the US service

area. Also in Europe the development of a WAAS configuration is under development [42]. The FAA and other organizations are furthermore working on a Local Area Augmentation System (LAAS) to provide the capability for Category 2/3 precision approaches as well as for taxiing in very low and even zero visibility conditions. The Category 3 integrity requirements are very severe:

- maximum warning time of 2 seconds
- maximum probability of an undetected failure of 10^{-9}

It is not possible to indicate if and when this can be obtained.

The only available solution to the Category 3 precision approach problem is the Microwave Landing System (MLS). Although MLS does not suffer from the multipath and interference problems, also on MLS equipped runways the capacity will reduce with the reduction of visibility due to such causes as:

- longer runway occupancy due to slower taxiing in IMC.
- minimum radar separation on approach.
- required taxiway separation.
- pilot and ground movement controller workload.

UK studies indicate that the capacity of MLS-equipped runways in Category 2, 3a and 3b conditions is about 80% higher than with Category 3 ILS-equipped runways [43].

4.5.3 Precision Radar Surveillance Systems

In IMC the Air Traffic Controller for the TMA has to ensure safe separation between the approaching aircraft. Some airports have parallel runways that due to the limited accuracy or update rate of the surveillance radar cannot be used as independent runways in IMC. The existing conventional rotating Secondary Surveillance Radars (SSRs) update their target positions only once per 4-5 seconds. The FAA postulates that at least two samples are required for the controller to recognize a aircraft course deviation error. The FAA decided that for airports with conventional SSRs only parallel runways separated more than 4300 ft may be considered as independent runways in IMC. For parallel runways separated between 4300 ft and 3400 ft, a stagger of 1.5 NM must be maintained on IMC. For airports as Raleigh - Durham International Airport in the USA this rule reduces the airport capacity by 40% in IMC resulting in a yearly loss of \$34 million. To solve this SSR update frequency problem MSI Services Inc. developed a Precision Runway Monitor (PRM). The PRM will allow an update frequency of two times per second. The PRM is an electronically scanned SSR capable of tracking 25 targets at altitudes between 50-15000 ft out to 32 miles [44].

A special problem is the simultaneous use of converging runways in IMC. In Europe approaches to converging runway in IMC are generally not authorized, resulting in a dramatic loss of capacity. The reason is that the pilot of the aircraft, if both would have to make a go-around, could not see each other and take the required evasive action.

In the US a Converging Runway Display Aid (CRDA) has been developed that assures separation during missed approaches by providing a certain stagger between the arriving aircraft. The size of the



stagger depends on the aircraft speed and performance variations and the runway geometries. The CRDA converts the geometry of the converging approaches into a single runway approach geometry. It projects an electronic ghost image of an aircraft approaching to one runway on to the approach path of the other converging runway allowing the radar controller to accurately monitor the required stagger distances. In figure 11 the principle of the CRDA is shown.

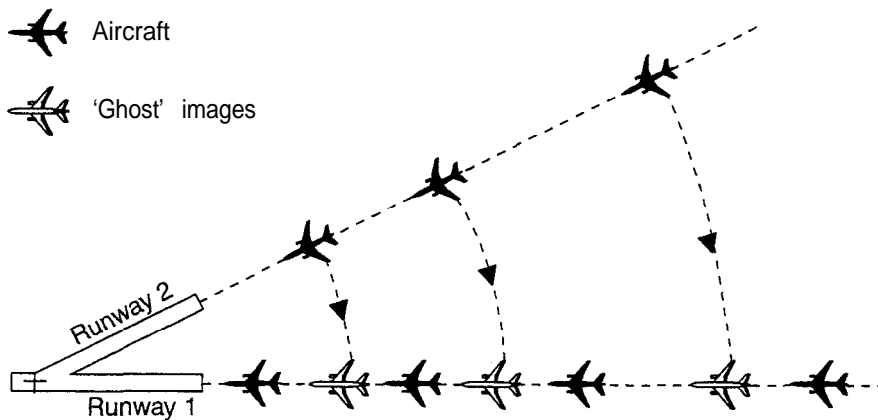

Fig. 11 Converging Runway Display Aid

Finally accurate radar surveillance will be required to monitor the taxiing aircraft. Although many airports are equipped with an Airport Surveillance Detection Equipment (ASDE) primary radar system, the lack of identification is a great handicap.

4.5.4 Optimal sequencing of approaching aircraft

If a maximum number of aircraft has to be handled, the runway capacity will be the dominant factor. To maximize the runway capacity, the airliners should be sequenced in such a way that, during the approach, the overall minimum separation distance between the airliners is obtained. One of the important factors in determining the required separation between succeeding airliners is the wake vortex from the wing of the preceding aircraft. The vortex descends and dissolves gradually with time. Furthermore, the vortex may be blown away from the approach path by crosswind.

Because at present the wake vortices cannot be easily detected, fixed separation distances are used to protect the trailing aircraft for the wake vortices of the leading aircraft. The strength of the generated wake vortex depends on the weight of the aircraft. The weight classes of the airliners are defined as light weight for aircraft with a mass of less than 7,000 kg, medium weight for aircraft between 7,000 and 136,000 kg and heavy-weight for aircraft with a mass of over 136,000 kg. In table 12 the required minimum separation distances are given for the situation in which heavy-weight, medium-weight or light-weight aircraft are followed by heavy-weight, medium-weight or light-weight aircraft.



Table 12 ICAO separation distances in Nautical Miles

Following aircraft	Leading aircraft	Heavy	Medium	Light
Heavy		4	3	3
Medium		5	3	3
Light		6	5	3

Maintaining the separation based on these three weight classes, however, does not always guarantee wake-vortex safety. The US National Transportation Safety Board (NTSB) provided data showing that, only in the US from 1983 till 1993, about fifty wake-vortex-caused accidents and incidents happened, resulting in 40 destroyed or seriously damaged aircraft and 27 persons killed and 8 seriously wounded [45]. To provide a better wake-vortex separation, NTSB proposes four weight classes; heavy aircraft with a mass larger than 300,000 lbs, large aircraft with a mass between 100,000 lbs and 300,000 lbs, medium aircraft with a mass between 30,000 lbs and 100,000 lbs and small aircraft with a mass of less than 30,000 lbs. NTSB suggests the separation distances to be as in table 13.

Table 13 NTSB suggested separation distances in Nautical Miles

Following aircraft	Leading aircraft	Heavy	Large	Medium	Small
Heavy		4	3	3	3
Large		5	4	3	3
Medium		6	5	3	3
Small		7	6	4	3

Ideally, when the available runway capacity has to be exploited fully, a batch of airliners entering the FIR would be sequenced to position the aircraft clustered by weight class, starting with the lightest weight class.

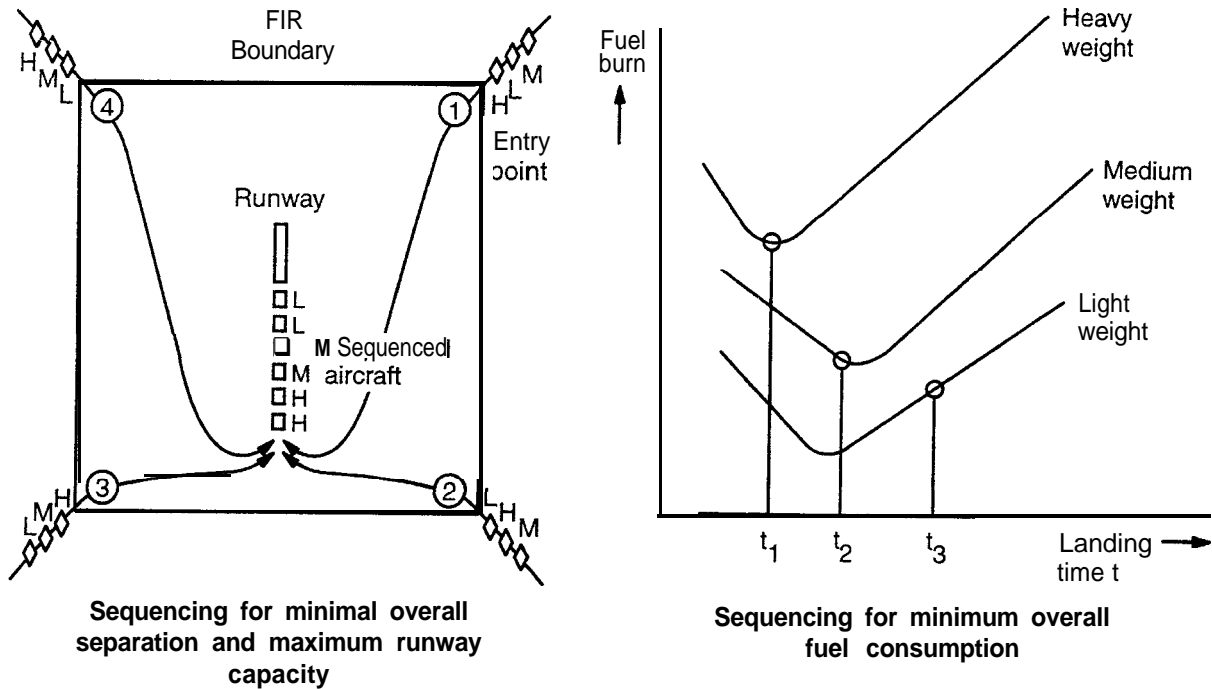

Fig. 12 Sequencing for minimal overall separation (and maximum runway capacity) or minimal overall fuel consumption

The ATM system should optimize the fuel consumption of the individual airliners within this group sequence. If the traffic load is less, more freedom in the sequencing of the airliners can be obtained. Then a better optimisation of arrival-time accuracy and fuel consumption for the individual aircraft can be obtained. Figure 12 shows how this optimal sequencing could be realized. But each aircraft has also a preference for minimum delay and minimum fuel consumption. An overall optimum has to be determined. A problem to be solved is how and by whom the optimization criteria will be set. For this optimization, computer assistance is required. The computer will have to be provided with the accurate actual meteorological information with respect to wind vector, wind gradient, temperature gradient as well as the short term forecast of this information ("nowcasting"). Furthermore, the computer will require the performance data, fuel consumption data and limitations of the airliners. With these data the optimal sequencing can be computed and provided to the Air Traffic Controller.

The NASA-Ames Research Center (US) has developed the Center Tracon Automation System (CTAS) as an advisory system for the Air Traffic Controller [46]. CTAS calculates an optimal sequencing of all arriving traffic and provides the Air Traffic Controller with the required Top of Descent, speed and vector advisories to control the air traffic in such a way that the aircraft will match the calculated optimal sequence. CTAS is installed at the airports of Denver and Dallas/Port Worth.

A similar optimal sequence advisory system, COMPAS, developed by the German Aerospace Research Institute (DLR), is installed at Frankfurt airport. It will be clear that, to provide the best overall optimum in runway, airspace, time and fuel use, the optimisation will have to cover all air traffic instead of only that of a single FIR. This requires further integration of and improved communication



between the ATC centers.

The digital datalink makes it possible to provide the ATC computer with accurate data on the aircraft performance and limitations, its preference with respect to arrival time and flight path and with the actual weather information at the location of the individual aircraft.

With improved ground-derived and aircraft-derived meteorological information, actual aircraft weight and improved wake-vortex-dispersion models, optimal separation distances can be computed.

From the weather information provided by the airliners, in combination with ground-derived meteorological information and the available runway configuration, the ATC computer can determine the overall optimum sequence for all arriving and departing traffic. The digital datalink can also be used to provide each individual aircraft with its ATC-computed individual (suboptimal) 4-D clearance.

In principle the use of the digital datalink between FMS-AFCS computers in the airliners and the ATC computer allows fully automated ATC. The reliability and integrity requirements of such an automated ATC system have to be an order of magnitude higher than those of the individual airliners. Furthermore, the automated ATC system should be able to cope with all possible contingencies and emergencies. As an example: in case of a total failure of the digital datalink capability or of the ATC computer system, pre-defined conflict-free escape flight trajectories towards a safe holding pattern for all aircraft should be provided for, until another ATC center, through a newly built-up datalink, can take over.

It is evident that the upgrading of the capacity of the ATC centers will have to be evolutionary rather than revolutionary. Furthermore, the future ATC will have to be able to serve fully-equipped airliners as well as minimally equipped aircraft. This means that the future ATC system will have to be human-centered in such a way that the Air Traffic Controller can decide which airliners will be handled fully automatic (through digital datalink), for which aircraft he will endorse computer calculated clearances through the digital datalink and which airliners he will handle through voice clearances.

4.5.5 Reduction of fuel consumption, emission and noise through Continuous Descent Approaches

Present-day ATC brings the approaching aircraft relatively soon to a relatively low altitude or a non-optimum speed. The aircraft will non-optimally descend to 2000 ft for the interception of the ILS localizer. After some time of level, stabilized flight the ILS glide slope will be intercepted for a stabilized 3-degree ILS approach.



The flaps are gradually extended, the undercarriage is lowered and full flaps are given. This type of approach results in a non-optimal fuel consumption, emission of exhaust gases and engine and airframe noise.

A significant improvement in fuel consumption, exhaust gas emission and external noise could be obtained by allowing the aircraft to make a Continuous Descent Approach with idle or minimal power settings from the Top of Descent till the Point of Intercept to the ILS Glide Slope.

In figure 13a the descent profiles and aircrafts configurations of the Conventional Approach and the Continuous Descent Approach are presented. The resulting approach noise footprints are presented in figure 13b.

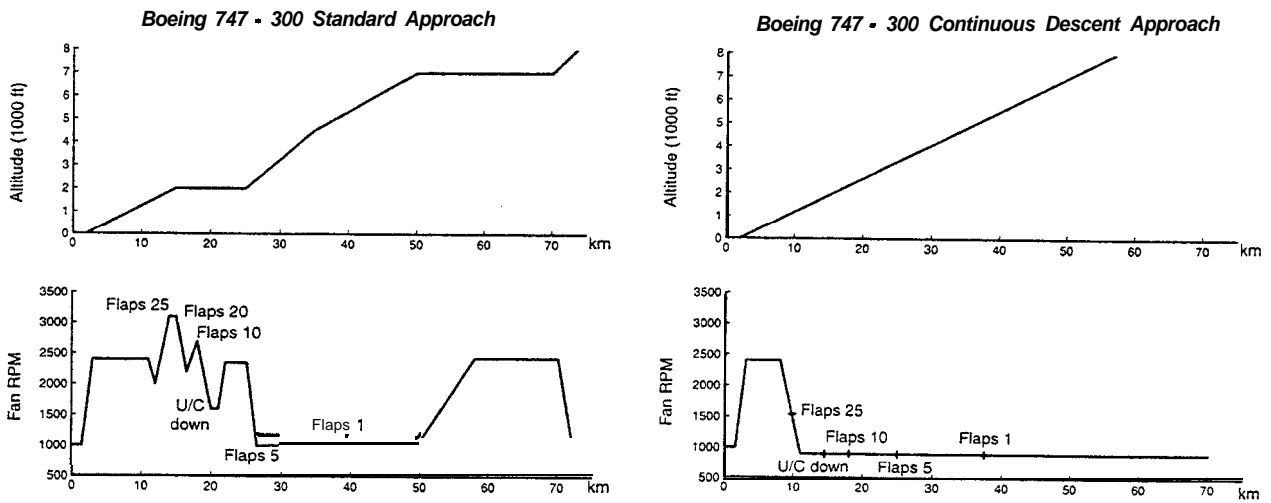

Fig. 13a Boeing 747-300 Standard Approach and Continuous Descent Approach

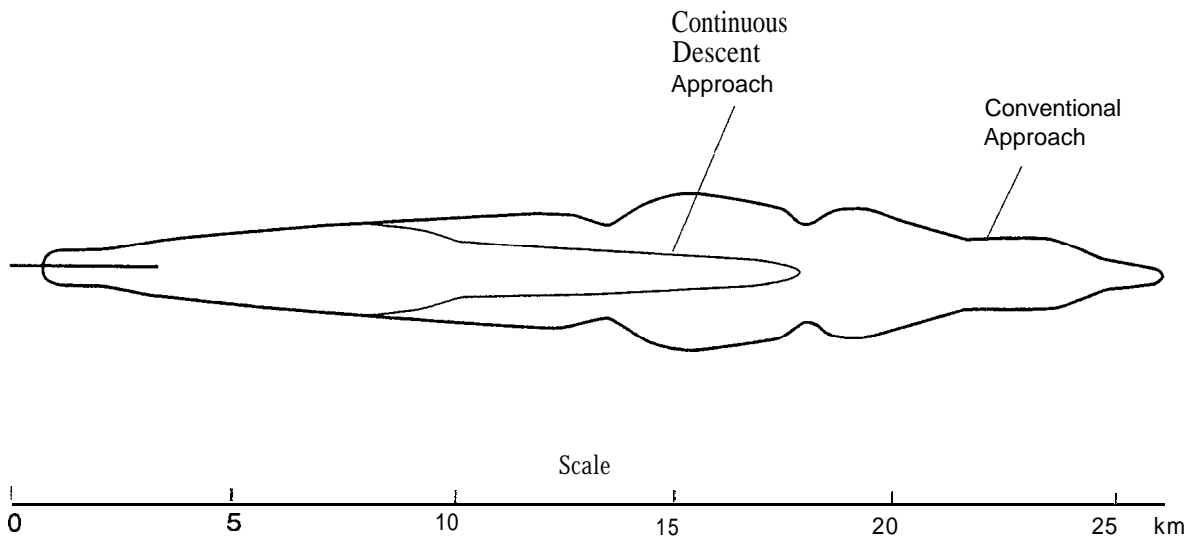

Fig. 13b B-747-300 noise footprints (standard approach and Continuous Descent Approach)



Of course such a Continuous Descent Approach would require the appropriate Flight Management Computer algorithms for the automatic execution of the approach. Furthermore an adequate display system for the pilot is required to enable him to monitor the correct execution of the 4D optimal descent with the non-stabilized configuration changes.

Also the Air Traffic Controller will need a new 3D display system which allows him to monitor the correct execution of multiple sequenced aircraft towards the same runway.

Furthermore the display system should be augmented by a computer-assisted input system that allows the Air Traffic Controller to react to malfunctions and non-complying aircraft quickly and safely.



5. Integrated free flight and 4D gate-to-gate ATM

5.1 National Route Program

In 1991 the FAA started the National Route Program (NRP). The aim of the NRP was to allow more freedom of routing for aircraft at the higher altitudes. The NRP however was limited to routes between certain pairs of cities at a minimum distance of 1500 miles apart. Despite this restriction the NRP is very successful. The FAA estimates the industry-wide annual savings to be \$ 40 million [47]. At present the NRP floor is 35,000 ft on the East Coast. West of the Mississippi it is 33,000 ft. The FAA is considering to lower the NRP floor to 29,000 ft. All airliners operate IFR under full ATC ground control. There is a limit to the capability of ATC to cope with the increasing number of airliners that will fly outside of the normal airway/sector structure. In table 14 an indication is given on the number of aircraft that operate per day over the US continent/airspace at and above Flight Levels over FL 310 [48].

Table 14 Daily Continental US Traffic above FL 310 (Sept. 16, 1994)

FL	Nr. of aircraft at FL	Nr. of aircraft above FL
450	203	203
430	250	453
410	1,035	1,488
390	1,846	3,334
370	3,924	7,258
350	6,233	13,503
330	5,907	19,409
310	3,680	23,089

5.2 Use of TCAS for In-Trail Climb

Because at present over the oceans no radar surveillance or satellite-based ADS is in existence, airliners have to comply with fixed altitudes, fixed speeds and fixed tracks (Organized Track System - OTS). To enable the faster airliners to overtake the slower ones, the FAA has started operational trials with In-Trail-Climb (ITC) procedures over the Pacific Ocean. For these ITC procedures TCAS is used by the following aircraft to determine the distance to the leading aircraft. Through VHF radio communication and use of the on-off switching of the transponder of the leading aircraft a positive identification of the leader is determined. After this distance determination and positive identification a "clearance to overtake" from ATC is requested [49]. At present North West, American Airlines, Singapore Airlines, Delta and United cooperate with the FAA in this ITC test. United Airlines estimates that the use of ITC saves 18,000 kg of fuel on an average long distance flight [50].



5.3 Free Flight

The Radio Technical Committee for Aeronautics (RTCA) defines "Free Flight" as: "*a safe and efficient flight operating capability under Instrument Flight Rules (IFR) in which operators have the freedom to select this path and speed in real time. Air traffic restrictions are only imposed to ensure separation, to preclude exceeding airport capacity, to prevent an authorized flight through special use airspace, and to ensure safety at flight. Restrictions are limited in extent and duration to correct the identifies problem.*" In the same report RTCA states that "*Free Flight is necessary to reduce the insufficient capacity, limited access and excessive restrictions that have resulted in escalated operation costs, increased delay and decreased efficiency for all users*" [51].

The Free Flight concept aims for "VFR flexibility with IFR protection". It assumes that when the pilot is provided with adequate information on the position and intent of all aircraft around the own aircraft, a safe separation can be maintained similar to VFR operations in good visibility. When all airlines are equipped with an advanced Traffic Display on which the identification and intended 4D flight path of all surrounding aircraft are provided, the pilots might take care of adequate separation themselves.

An advanced TCAS might be able to provide this Traffic Display as well as to warn the pilots for imminent collision dangers. Through the ATC Surveillance Systems, the Air Traffic Controllers could monitor this process, and if their assistance would be necessary they could provide directions for a solution of conflicts. The ensuring of safety would be a shared responsibility of the Air Traffic Controllers and the pilots, where the Air Traffic Controllers would have to provide the long-term (strategic) safety and the pilots the short-term (tactical) safety.

The airlines hope that the introduction of Free Flight will significantly increase the efficiency of air transport. The US Air Transport Association estimates the annual operating loss figure for the US airlines at \$ 3.5 billion. This figure does not include loss of productivity of travellers or passenger inconvenience nor does it include other classes of air space users such as General Aviation.

5.4 Integrated Free Flight and 4D Gate-to-Gate ATM

Near the high-density airports, Air Traffic Control will have to control the total traffic in the air and on the ground. Ground-based computer systems would have to determine the optimal sequencing of the approaching and departing aircraft and provide the cleared 4D flight paths to the aircraft via a two-way digital datalink. The pilot would have to check these cleared flight paths using their onboard Flight Management Systems for feasibility before accepting. After this 4D planning the aircraft would have to follow the 4D flight paths until the arrival at the gate.

In figure 14 the control loop block diagram of this future Free Flight and 4D Gate-to-Gate ATM system is given.

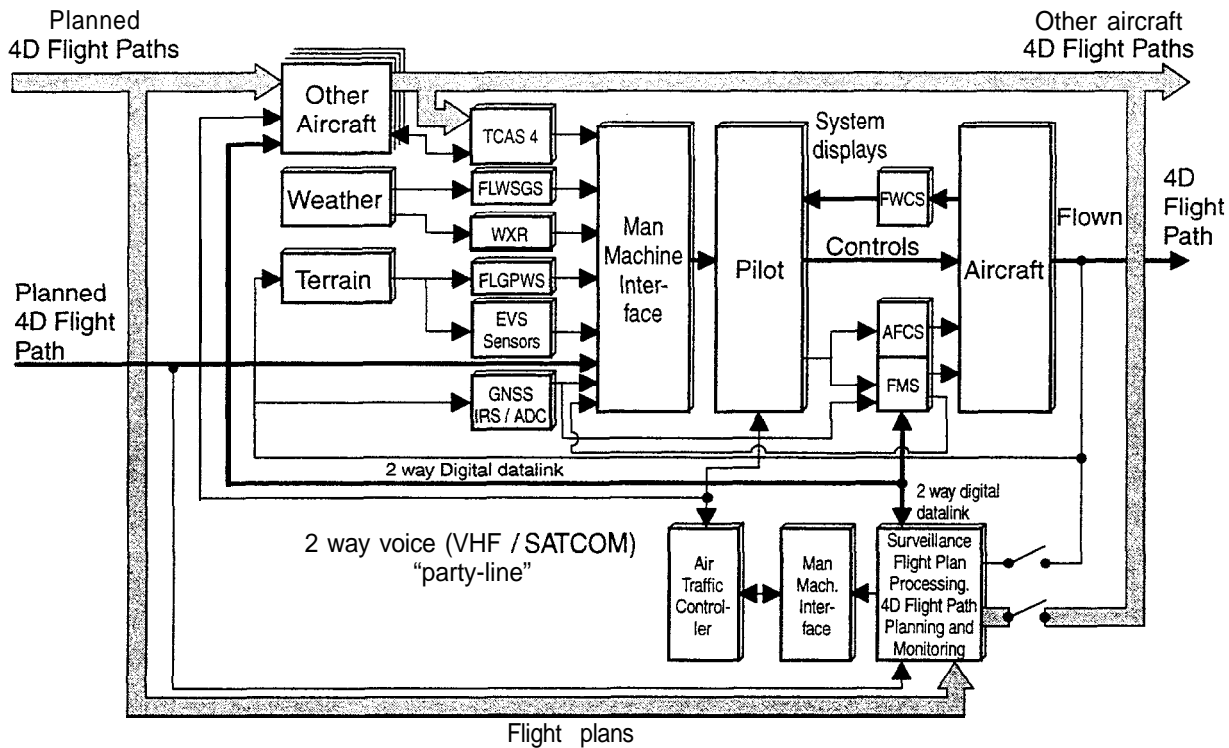

Fig. 14 Free Flight and 4D Gate-to-Gate ATM

The pilot is informed about all other aircraft and their flight plans/intentions through an optimized Man-Machine Interface. The Integrated Outside Vision System would provide the pilot with information about the terrain, weather state, cleared 4D flight path, etc.

The Air Traffic Controller would observe through his optimal Man-Machine Interface the en-route air traffic including their intentions. Long-, Medium- and Short-Term Conflict Detection algorithms in the ATM computer would assist him in detecting possible conflicting situations.

The Air Traffic Controller would monitor that all aircraft would accurately follow their cleared 4D flight paths. Computer algorithms would help him in his monitoring function and provide him with advise to solve emerging problems.

New Man-Machine Interface systems for the Air Traffic Controller will have to be developed to allow him to do so with an acceptable workload. Adequate research, tests and evaluation is required to answer questions as:

- What kind of displays and tools are required for an Air Traffic Controller who has to handle such a mix of traffic?
- How can an ATC computer system/datalink failure be handled? Can pre-stored procedures be worked out to automatically clear all aircraft through pre-computed collision-free trajectories to an holding area in case of an ATC system or datalink failure?
- How long will it take to take-over the control of the air traffic from an another ATC center in case of failures, etc.?



6 Required ATM research and research facilities

To develop, test and evaluate the new computer assisted/automated ATM concepts and to evaluate the Man-Machine Interface aspects, new ATM research facilities are required. In these new ATM research facilities the potential airspace and airport capacity increase, individual and overall fuel consumption, the schedule accuracy, etc. have to be analyzed taking into account maximum datalink capacity, possible wind/weather changes, datalink delay variations, mix of light-, medium- and heavy-weight aircraft, etc. The effects of system failures, datalink failures and the capability of the Air Traffic Controller to safely handle these emergencies and contingencies have to be demonstrated. New Man-Machine Interfaces for the pilots as well as for the air traffic controller have to be evaluated for effectivity, workload, etc.

For the evaluation of the potential benefits of new ATM concepts fast-time simulation tools as "Total Airspace and Airport Modeller" (TAAM) are used. For the evaluation of the role of the human in the future ATM system real-time facilities are necessary. In the Netherlands the National Aerospace Laboratory NLR has developed the NLR ATM Research Simulator (NARSIM) [52]. NARSIM consists of a powerful central computer containing the mathematical models of aircraft, meteo, surveillance radar, etc. Simulation pilots ("blip drivers") can be used to simulate the traffic load. The Man-Machine Interface for the air traffic controllers consists of multiple large 2000 x 2000 pixel raster-scan colour displays, roller balls, touch input devices, keyboards, etc.

NARSIM has the capability to include real Amsterdam airport ATC data. Furthermore NARSIM can be connected to the NLR research flight simulators as well as to the twin-jet Cessna Citation (jointly owned by NLR and the Delft University of Technology) and the NLR twin-turboprop Fairchild Metro II. The Man-Machine Interface for the pilot consists primarily of multiple Electronic Flight Instrument Systems (EFIS) colour displays (optional in combination with input devices, such as a roller ball, touch pad or touch screen), multiple Control and Display Units (CDU's), audio and radio communication panels. Figure 15 shows a block diagram of this NLR ATM Research Infrastructure.

NARSIM has already been used for various national research projects, such as:

- Development of new display and control concepts for the future Schiphol ATC system,
- Development of Short Term Conflict Alert (STCA) concepts.
- Development of controller assistance tools for the handling of arrivals on dependent converging runways under low-visibility conditions.
- Evaluation of new digital datalink concepts and consequences to the pilot's situational awareness (lack of "party-line" information).

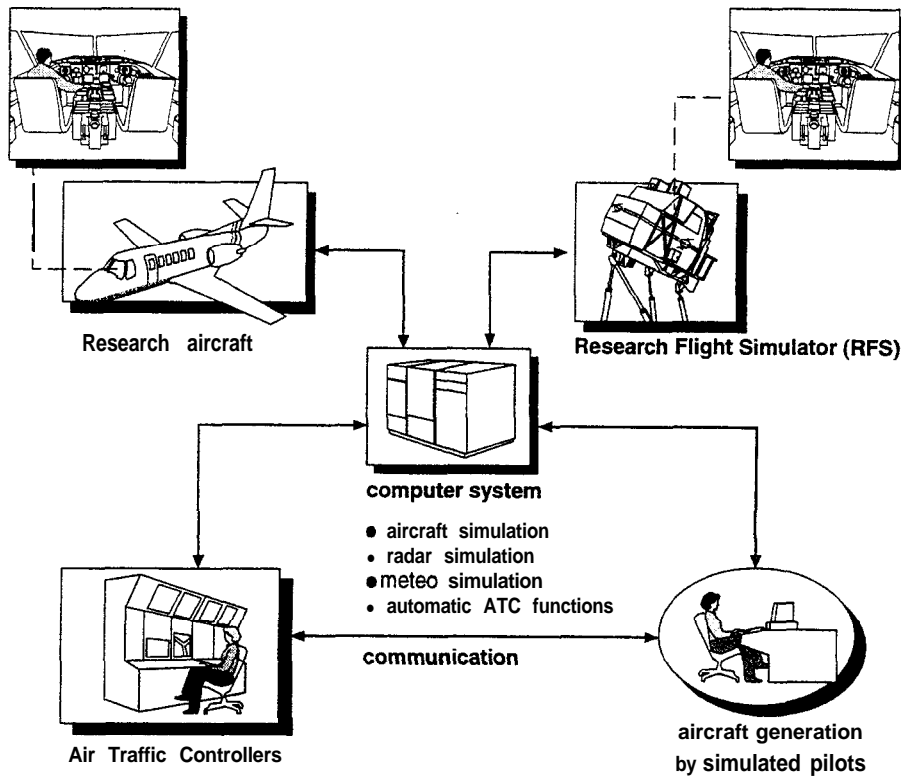

Fig. 15 NLR Air Traffic Management Research Infrastructure

To investigate the potential advantages of fully automated ATM, NLR in close cooperation with NASA-Ames Research Center, has created a special test facility consisting of a combination of NARSIM and of a further developed version of the NASA-ARC CTAS.

By adapting CTAS for the Netherlands airspace and by adding a **datalink** feature and several decision and control generation algorithms, the thus automated CTAS can be used to generate the clearances for multiple approaching aircraft, transmit these clearances by means of a digital **datalink** to the (simulated) aircraft of NARSIM and automatically control the traffic flow. With this automated CTAS-NARSIM ATM simulation facility, a number of simulations of various traffic mixes for runway 27 of Schiphol Airport was executed [53]. In December 1993 the automated CTAS-NARSIM configuration was connected by means of an Internet digital **datalink** with the Advanced Concepts Flight Simulator (ACFS) of the NASA-Ames Research Center Crew-Vehicle System Research Facility (CVSRF) in California. Following the automated CTAS-NARSIM generated clearances, the NASA pilot in the ACFS in California flew a perfect approach followed by a manual "landing" on Schiphol Airport in the Netherlands.

In the future it is expected that ATM infrastructures will be designed that can fully automatically control adequately equipped airliners. But because the development towards the automatic ATM environment has to be evolutionary, for a long time the ATM configuration will have to be able to handle a mix of airliners with different levels of automation. So, for ATM research purposes it has to be possible to investigate the different combinations of ATM technology and airliner avionics configurations (Table 15).



Table 15 Possible combinations of ATM environment and aircraft avionics configuration

Aircraft avionics	ATM avionics	Fully Automatic	Computer advisory by datalink enabled by ATC	Computer advisory by voice	Radar and Voice
<i>Fully Automatic</i> EFMS/Datalink Auto Upload		X	X	X	X
<i>Semi Automatic</i> Datalink + display pilot enabled loading into FMS		X	X	X	X
<i>Semi Automatic</i> Datalink + display		X	X	X	X
<i>Manual</i> Voice clearance		—	—	X	X

In the ATM research studies, also the dynamics and characteristics of the ATM control loop have to be investigated. The effects of the capacity of the ATM and datalink systems and associated delays, aircraft and pilot dynamics, surveillance system dynamics, weather changes and other disturbances will have to be studied with respect to system capacity and safety (Fig. 16).

In the coming years the above-mentioned NLR ATM Research Infrastructure will be used to investigate the different advanced ATM concepts and the related human factors aspects for a mix of airliners with different avionics configurations.

An important target of this NLR ATM research activity is the provision of adequate tools for the pilots and air traffic controllers to keep them "in-the-loop" so that they can safely take over in case of malfunctions or emergencies. Special emphasis will be placed on advanced displays that will provide the human with improved "situational awareness".

In the context of the Programme for Harmonized Air Traffic Management Research in Eurocontrol (PHARE), NLR is involved in the development of various advanced ATM research tools [54] and associated Man Machine Interfaces. One of the advanced new tools of PHARE is the Experimental Flight Management System (EFMS). The EFMS by means of a digital datalink enables the pilot to negotiate an optimal 4D flight path with ATC, and after the clearance of the 4D trajectory the EFMS enables the pilot to execute this cleared 4D trajectory [55]. The EFMS has been tested in the BAC 1-11 (DRA) research aircraft and in the Fairchild Metro II (NLR) research aircraft using NARSIM and a VHF digital datalink.

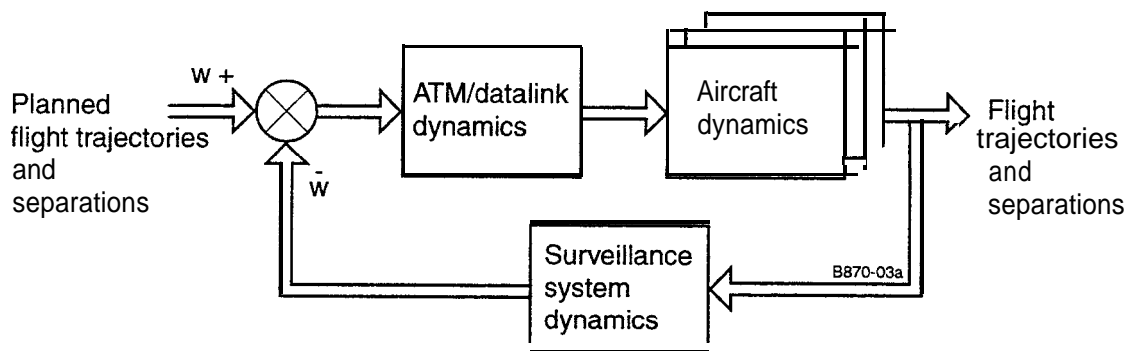

Fig. 16 Air Traffic Control system dynamics

Furthermore, NLR is involved in the development of the Man Machine Interface for both the air traffic controller as well as the pilot to operate effectively in the PHARE 4D ATM environment. In order to facilitate Man Machine Interface prototyping and evaluation, NLR Avionics Display Development and Evaluation System (NADDES) has been developed. NADDES enables NLR to prototype and evaluate various (interactive) displays in the Research Flight Simulator or the Avionics Research Testbed (ART). PHARE will provide an integrated and unified European ATM research facility for concept development, test and evaluation.

In Europe the ECAC, the European Union and Eurocontrol determine what research has to be executed to support the future European Air Traffic Management System (EATMS). In 1992 the ECAC Ministers of Transport launched an Airport Strategy to complement their En-Route Strategy designed to increase the efficiency and capacity in and around Europe's airports. A Project Board was created under the title of APATSI (Airport/Air Traffic System Interface). An independent study was started to review the current ATC procedures designed the increase capacity.

The APATSI Project Board issued an ECAC Manual on these procedures in 1994 with the objective to encourage the implementation in the ECAC States [56]. Also new ATC procedures were identified which could increase capacity in the medium term, based on the use of computer-assisted ATC systems.

The APATSI document discusses :

- Independent approaches to parallel or near parallel instrument runways using a runway monitoring system.
- Sequencing of arriving aircraft using computer-assisted tools.
- Dependent Converging Instrument Approaches using the Converging Runway Display Aid (CRDA).
- Computer-assisted sequencing of departure traffic.
- Combined arrival and departure sequencing.



In 1995 the project for the "Preparation of an R&D Programme in support of EATMS" (PRAISE) was started by Eurocontrol to prepare on R&D Programme in support of the definition, specification, validation and prototype of the EATMS concept of its main components [57].

The NLR research programmes will be integrated and harmonized with the ECAC, Eurocontrol and EU ATM Research Programmes (PHARE, EATMS, PRAISE, ECARDA) as well as with US-FAA Research Programmes (AATM)) to assist and cooperate in the development of future safe, efficient and environmentally friendly ATM systems.



7 Conclusions

Air transport has developed from a hazardous, weather-dependent adventure to a reliable, efficient and almost all-weather means of transport.

The introduction of blind-flying instruments, radio communication and navigation and radar-based surveillance has greatly increased the safety and reliability of air transport. The introduction of metal airliners with reliable jet engines has greatly increased the safety, economy and capacity of air transport.

Between 1970 and 1995 the number of subsonic turbojet airliners tripled and the number of Passenger-Kilometres more than quadrupled. The safety level improved continuously and finally stabilized in the last decade. The increase in production and safety was made possible by steadily improving aircraft, engines, systems and avionics as well as by improving ATC. For the next two decades, a further doubling of the number of subsonic airliners and an increase by a factor of three-four of the number of Passenger-Kilometres is forecasted. To enable the safe, environmentally friendly and efficient handling of the increasing air traffic, it is necessary to increase the number of runways, airports and passenger terminals as well as to provide advanced avionics systems based on satellite navigation and communication, MLS, digital datalinks and more automated ATM to increase the efficiency of the use of airspace and runways.

To further enhance air transport safety, the worldwide infrastructure should be brought to the standards now used in the USA, Western Europe, Australia and a limited number of other nations.

Satellite navigation and communication will provide important ways of improving worldwide accurate navigation and potentially automatic approach and landing, worldwide high-quality digital and voice communication and worldwide Automatic Dependent Surveillance. Furthermore, standard procedures and training programmes to adhere to these procedures should be further developed.

Finally, both safety and operational capability can be further improved by the introduction of an improved "safety net" consisting of improved forward-looking GPWS, improved windshear warning systems, improved AFCS mode annunciator system, improved ice detection system and improved TCAS as well as by providing pilots and Air Traffic Controllers with improved Man-Machine Interface systems on which the fused information from multiple sensors is presented in a "natural" intuitive way. Research into such aspects as workload and failure handling is required for the development of new Man-Machine Interfaces for Air Traffic Controllers. The gradual introduction of automation in air traffic management has to be studied taking into account several different avionics configurations. The introduction of the new Communication, Navigation and Surveillance/Air Traffic Management Systems, automation and computer-assistance systems as well as the new Man-Machine Interface Systems has to be evolutionary.



Before the new systems and procedures can be introduced, extensive research, evaluation and demonstration programmes are necessary to prove to the pilots, Air Traffic Controllers as well as to the airline managers and Civil Aviation Authorities the benefits and operational feasibility of the new systems.

For these research, evaluation and demonstration programmes research flight simulators, adequately equipped research aircraft and research air traffic control simulators, and networking of these research facilities will be required to provide the necessary simulation environments.

International coordination and standardization is absolutely essential to provide international standardized and accepted future ATM and avionics systems.

8 References

- [1] McFarland, M.; The papers of Wilbur and Orville Wright: McGraw Hill, 1953
- [2] Taylor, J.J.H.; Milestones of Flight: Jane's, 1983
- [3] Klaauw, B. v.d.; The immortal alphabet: Wedrego B.V., 1981
- [4] Doolittle, J.H.; Flying an airplane in fog: SAE Journal, Vol XXVI, March 1930
- [5] Jones, R.V.; Most secret war: Hamish Hamilton Ltd, 1978
- [6] ICAO; Annexes to the Convention of International Civil Aviation
- [7] ICAO; Annual Civil Aviation Report: ICAO Journal, July/August 1995
- [8] Learmount, D.; The arrogant decade: Flight International, January 1990
- [9] Proctor, P.; Industry Group Begins Worldwide Safety Push:
Aviation Week and Space Technology, June 7, 1993
- [10] Klass, P.; Near Collision of TCAS Aircraft Linked to Controller, Pilot:
Aviation Week and Space Technology, December 14, 1992
- [11] Miller, C.A. and others; Results of the Traffic Alert and Collision Avoidance System
Transition Program: 46th Annual International Air Safety Seminar of the Flight Safety
Foundation, Kuala Lumpur, Malaysia, November 8-11, 1993
- [12] AECMA; Aircraft and the Environment, A European View: AECMA, 1993
- [13] Shifrin, C.A.; Airbus sees robust demand in 2014:
Aviation Week and Space Technology, March 27, 1995
- [14] Euromart Consortium; Long Term Plan for Aeronautics Research and Technology,
April 1992
- [15] Boeing Commercial Airplane Group, Accident Prevention Strategies, "Removing Links
in the Accident Chain", October 1993
- [16] Bowles, R.L.; Reducing Windshear Risk through Airborne Systems Technology:
17th Congress of the International Council of the Aeronautical Sciences,
Stockholm, Sweden, September 9-14, 1990
- [17] O'lonc, R.G.; Pinatubo Eruption Spotlights Volcanic Hazards to Aircraft:
Aviation Week and Space Technology, July 15, 1991
- [18] Possehl, S.R.; Russian Roulette at 31.000 ft: Aerospace America, June 1996
- [19] Stockhouse, J.; Danger area: Volcanic Dust: Aerospace World, November 1991
- [20] Sarter, B.; Woods, David D.; Situation Awareness: Critical but Ill-Defended
Phenomenon: The International Journal of Aviation Psychology I (1), 45-57, 1991
- [21] Hoover, G.W.; Stop Saturating Pilots with Alphanumeric Hieroglyphics:
Aviation Week and Space Technology, June 15, 1992
- [22] Gaines, M.; A shot in the dark: Flight International, August 21, 1991
- [23] Miller, B.; Stretching the RVRs with Enhanced Vision:
Aviation International News, May 1, 1992

- [24] Horne, W.F.; others; Synthetic Vision System Technology Demonstration, Methodology and Results to Date: SAE Technical Paper Series 921971. Aerotech 1992, Anaheim, California, October 5-8, 1992
- [25] Pavel, M., Larimer, J., Ahumada, A.; Sensor Fusion for Synthetic Vision: AIAA Computing in Aerospace Conference, 1994
- [26] Kaiser, M.K.; Sweet, Barbara T. (eds); Proceedings of the Augmented Visual Display Research Workshop: NASA Conference Publication 10128, March 10-12, 1993
- [27] Dornheim, M.A.; FAA Flight Tests to Measure Synthetic Vision Performance: Aviation Week and Space Technology, January 20, 1992
- [28] Hughes, D.; Boeing, United Pursue Major Cockpit Advance: Aviation Week and Space Technology, November 23, 1992
- [29] Daly, K.; MADL lands FAA approval for EVS: Flight International, February 8, 1994
- [30] Eurocontrol; EATMS User Requirements Document: Eurocontrol, September 6, 1995
- [31] AEA Air Traffic Control in Europe; Association of European Airlines, February 1989
- [32] ECAC; Air Traffic Control in Europe; ECAC Strategy for the 1990's: European Civil Aviation Conference, April 1990
- [33] Jeziorski, A.; EATCHIP halves ATC delays: Flight International, Jan. 31 - Febr. 1996
- [34] Lambert, Y.; Breaking new ground: World Aerospace Development, 1995
- [35] Moxon, J.; Tahiti's FANS makes headway: Flight International, Jan. 31 - Febr. 6, 1996
- [36] Fee, J.J. and Simpson T.R.; A new era in oceanic ATC: Aerospace America, October 1995
- [37] Anon; China plans ATM tests: Flight International, February 14-20, 1996
- [38] Padfield, R.R.; Hinson hits the hustings to champion new airport capacity: Aviation International News, November 1, 1994
- [39] Jeppesen; Cat. II or Cat. III approaches any one? Where in the world are the runways?: Aviation International News, November 1, 1994
- [40] Sheridan, J.; ICAO maps transition plan for future use of ILS/GPS: Aviation International News, May 1, 1995
- [41] FAA; Satellite Navigation Program Master Plan: FAA Satellite Program Office (AND-510), August 31, 1995
- [42] Covault, G.; Thomson wins nav segment: Aviation Week and Space Technology, Jan. 22, 1996
- [43] Anon; MLS runway utilisation benefits; Assess the economical and financial implications of ILS/MLS transition: Input to the Special Communication / Operations Divisional Meeting of ICAO, Montreal, March 27-April 7, 1995
- [44] Nordwell, B.D.; Radar cuts delays on parallel runways: Aviation Week and Space Technology, July 26, 1993



- [45] Padfield, R.R.; NTSB Contests wake vortex rules while exonerating Boeing 757: Aviation International News, July 1, 1994
- [46] Erzberger, H., Davis, T.J. and Green, S.; Design of Center-Tracon Automation System: AGARD GCP 56th Symposium on Machine Intelligence in Air Traffic Management, May 11-14, 1993, Berlin / Germany
- [47] Nordwell, B.D.; Free Flight: ATC model for the next 50 years: Aviation Week and Space Technology, July 31, 1995
- [48] Nordwell, B.D.; Cultural Shift Key To New Concept: Aviation Week and Space Technology, July 31, 1995
- [49] Phillips, E.H.; TCAS key to In-trail climb: Aviation Week and Space Technology, May 2, 1994
- [50] Fee, J.J. and Simpson, T.R.; A new area in oceanic ATC: Aerospace America, October 1995
- [51] RTCA; Report of the RTCA Board of Directors Select Committee on Free Flight, Jan. 18, 1995: RTCA Washington DC
- [52] Have, H. ten; The Development of the NLR ATC Research Simulator (NARSIM) Design philosophy and potential for ATM Research: NLR TP 92300 U
- [53] Braven, W. den, Bos, H. v.d.; Simulation of fully automatic Air Traffic Control Concepts: AGARD GCP 56th Symposium on Machine Intelligence in Air Traffic Management, May 11-14, 1993, Berlin / Germany
- [54] Blom, H.A.P. and others; The Phare Advanced Tools: NLR TP 93334 U
- [55] Brüggem, J.; The experimental Flight Management System, an Air Traffic Management Tool: NLR TP 92253 U
- [56] ECAC Airports Bureau; ECAC APATSI Draft Document on Medium Term ATC Procedures and Techniques, November 1994
- [57] Berghuis van Woortman, H.; Praise, EATMS R&D tasks description: Eurocontrol, September 14, 1995



9 Abbreviations and acronyms

A/C	Aircraft
ACC	Area Control Center
ADI	Attitude Director Indicator
ADS	Automatic Dependent Surveillance / Air Data System
AEA	Association of European Airlines
AFCS	Automatic Flight Control System
ALS	Automatic Landing System
APATSI	Airport Air Traffic System Interface
ART	Avionics Research Testbed
ARTAS	ATC Radar and Tracker Server
ASDE	Airport Surface Detection Equipment
ATC	Air Traffic Control
ATM	Air Traffic Management
ATT	Attitude
BLEU	Blind Landing Experimental Unit
BEA	British European Airways
CAD	Computer Aided Design
CAM	Computer Aided Manufacturing
CDU	Command Display Unit
CFD	Computational Fluid Dynamics
CFIT	Controlled Flight Into Terrain
CFMU	Central Flow Management Unit
CIS	Commonwealth of Independent States
CNS	Communication, Navigation and Surveillance
COMPAS	Computer Oriented Metering, Planning and Advisory System
CRDA	Converging Runway Display Aid
CRT	Cathode Ray Tube
CTAS	Center Tracon Automation System
CTR	Control Zone
CVSRF	Crew Vehicle System Research Facility





dB	Decibel
DH	Decision Height
DLR	Deutsche Forschungsanstalt für Luft- und Raumfahrt
DME	Distance Measuring Equipment
DOC	Direct Operating Cost
EATCHIP	European Air Traffic Control Harmonization and Integration Programme
EATMS	European Air Traffic Management System
ECAC	European Civil Aviation Conference
ECAM	Electronic Centralized Aircraft Monitoring
EFIS	Electronic Flight Instrument System
EFMS	Experimental Flight Management System
ESAS	Enhanced Situational Awareness System
ETVS	Enhanced Terrain Vision System
FAA	Federal Aviation Administration
FADEC	Full Authority Digital Engine Control
FANS	Future Air Navigation System
FAR	Federal Aviation Regulation
FBW	Fly-By-Wire
FIR	Flight Information Region
FLIR	Forward-Looking Infra-Red
FM	Frequency Modulation
FMS	Flight Management System
FWCS	Flight Warning Computer System
GPS	Global Positioning System
GPWS	Ground Proximity Warning System
HDG	Heading
HF	High Frequency (3-30 MHz)
HMD	Head-Mounted Display
HST	Horizontal Situation Indicator
HUD	Head-Up Display



ICAO	International Civil Aviation Organization
IFF	Identification Friend or Foe
IFR	Instrument Flight Rules
IIR	Imaging Infra-Red
ILS	Instrument Landing System
IMC	Instrument Meteorological Conditions
INS	Inertial Navigation System
IOVS	Integrated Outside Vision System
IR	Infra-Red
IRS	Inertial Reference System
ITC	In-Trail Climb
JAA	Joint Aviation Authorities
JTIDS	Joint Tactical Information Distribution System
KE	Kosten Unit
KLM	Koninklijke Luchtvaart Maatschappij
LAAS	Local Area Augmentation System
LCD	Liquid Crystal Display
LLTV	Low-Light-level Television
LORAN	Long Range Navigation
LOS	Line of Sight
MLS	Microwave Landing System
MMW	Millimetre Wave
MSAWS	Minimum Safe Altitude Warning System
NACA	National Advisory Committee for Aeronautics
NADDES	NLR Avionics Display Development and Evaluation System
NARSIM	NLR ATC Research Simulator
NASA	National Aeronautics and Space Administration
NDB	Non-Directional Beacon
ND	Navigation Display
NLR	(Netherlands) Nationaal Lucht- en Ruimtevaartlaboratorium
NM	Nautical Mile (1852 meters)
NOX	Nitrogen Oxides
NRP	National Route Programme
NTSB	National Transportation Safety Board



OTS	Organized Track System
PFD	Primary Flight Display
PHARE	Programme for Harmonized Air Traffic Management Research in Eurocontrol
PIREP	Pilot Report
PR	Primary Radar
PRAISE	Preparation of an R&D Programme in Support of EATMS
PRC	People's Republic of China
PRM	Precision Runway Monitor
RALT	Radio Altimeter
RDF	Radio Direction Finding
RFS	Research Flight Simulator
RTCA	Radio Technical Commission for Aeronautics
RVR	Runway Visual Range
SFC	Specific Fuel Consumption
SID	Standard Instrument Departure
SSR	Secondary Surveillance Radar
SSR-S	Secondary Surveillance Radar Mode S
STAR	Standard Arrival Route
STCA	Short Term Conflict Alert
STVS	Synthetic Terrain Vision System
TCAS	Traffic Alert and Collision Avoidance System
TMA	Terminal Manoeuvring Area
VDF	VHF Direction Finder
VFR	Visual Flight Rules
VHF	Very High Frequency (30-300 MHz)
VLf	Very Low Frequency (3-30 kHz)
VMC	Visual Meteorological Conditions
VOR	VHF Omnidirectional Radio-range
WAAS	Wide Area Augmentation System
WXR	Weather Radar