



NLR-TP-2015-365

In-flight non-intrusive measurement of wing dynamics and of the aileron and flap deflection and deformation

H.W. Jentink, P. Ružicka, H.P.J. Veerman and J.H. Breeman

Nationaal Lucht- en Ruimtevaartlaboratorium

National Aerospace Laboratory NLR

Anthony Fokkerweg 2

P.O. Box 90502

1006 BM Amsterdam

The Netherlands

Telephone +31 (0)88 511 31 13

Fax +31 (0)88 511 32 10

www.nlr.nl



Executive summary

In-flight non-intrusive measurement of wing dynamics and of the aileron and flap deflection and deformation

Report no.

NLR-TP-2015-365

Author(s)

H.W. Jentink
 P. Ružicka
 H.P.J. Veerman
 J.H. Breeman

Report classification

UNCLASSIFIED

Date

December 2015

Knowledge area(s)

Flight Test Systems

Descriptor(s)

Flight Test Instrumentation
 Wing Deformation
 Non-intrusive
 Image Correlation

Problem area

The in-flight measurement of motion of the wing and of the movable parts of the wing with high spatial resolution, bandwidth and accuracy and with instrumentation easy to install on the aircraft is the challenge addressed in this document. Instrumentation comprising a video camera and a speckled pattern on the wing section under investigation can provide the capability applying the Image Pattern Correlation Technique (IPCT).

Description of work

The technology to determine the deflection and deformation of an aileron and the capability to measure wing dynamics is presented. Flight test campaigns

were flown with the EVEKTOR Cobra and the NLR Fairchild Metro II to investigate the measurement capabilities.

Finally a software tool providing a Graphical User Interface (GUI) was developed to improve the efficiency of applying IPCT further and to improve the user friendliness.

Results and conclusions

IPCT, a new technique for measuring the wing deformation, requires a small installation effort for the instrumentation and provides high bandwidth, high resolution and accurate results. The technique can be applied for the movable parts of the wing where both the deflection of the surface and the deformation can be determined.

This report is based on a presentation held at the SFTE-EC Symposium 2015, Seville, Spain, October 6-8, 2015.

Geometrical information is used of the camera position relative to the measurement areas for applying the IPCT technique with one camera. This information is either available or can be measured on the ground. For determining the deflections of movable parts of the wing the rotation axis has to be determined, both geometrically relative to the camera and in the images to be processed. As the rotation axis moves together with the wing this has to be determined per processed image. The accuracy for determining the axis is critical for accurate deflection information of the control surface.

Deflections of the wing were measured on the ground and in-flight with a bandwidth suited for flutter investigations. The measurement of eigen frequencies of the wing with IPCT and accelerometers on the ground are in agreement. Excitation of vibrations in-flight by hitting the steering wheel was not sufficient for flutter investigations at the airspeeds flown.

The installation of the cameras stiffly enough to sustain all loads experienced in aircraft predictably, or to be able to correct for camera motion, needs further development. This will make the method suitable for amongst others flight flutter tests.

A software tool providing a Graphical User Interface was developed for applying IPCT image processing easily. A Flight Test Engineer with a basic knowledge of the technique and the measurement goals should be able to process images in a short time into plots and time traces of wing parameters.

Applicability

The method developed can be applied for measuring wing deformation, but with another installation of the cameras on the aircraft also deformations of other parts of the aircraft can be determined. For instance rudder deflection and deformation. And even more, the deformation and deflection of structures in a general sense may be dealt with.



NLR-TP-2015-365

In-flight non-intrusive measurement of wing dynamics and of the aileron and flap deflection and deformation

H.W. Jentink, P. Ružicka¹, H.P.J. Veerman and J.H. Breeman



¹ EVEKTOR

This report is based on a presentation held at the SFTE-EC Symposium 2015, Seville, Spain, October 6-8, 2015.

The contents of this report may be cited on condition that full credit is given to NLR and the authors.

Customer European Commission
Contract number ACP0-GA-2010-266107
Owner NLR
Division NLR Aerospace Systems
Distribution Unlimited
Classification of title Unclassified
Date December 2015

Approved by:

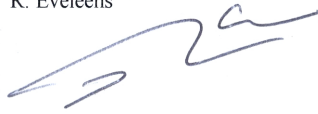
| | | |
|---|---|--|
| Author H.W. Jentink  | Reviewer H.P.J. Veerman  | Managing department R. Eveleens  |
| Date: 2 Dec 2015 | Date: 2 Dec 2015 | Date: 3-12-2015 |

Contents

| | | |
|----------|---|-----------|
| 1 | Abstract | 5 |
| 2 | Introduction | 5 |
| 3 | Methodology for determining wing deformation | 7 |
| 3.1 | Wing deformation | 7 |
| 3.2 | Deflection and deformation measurements on movable parts of the wing | 9 |
| 4 | Instrumentation of the aircraft | 10 |
| 4.1 | Fairchild Metro II | 11 |
| 4.2 | Evektor Cobra | 12 |
| 5 | Processing of images | 13 |
| 6 | Measuring wing deformation dynamics | 14 |
| 6.1 | Landing | 14 |
| 6.2 | Wing vibration measurement | 16 |
| 7 | IPCT for measuring aileron and flap deflections and deformations | 16 |
| 7.1 | Aileron deflection and deformation measurements in flight | 18 |
| 8 | Conclusion | 20 |
| 9 | References | 21 |
| | Acknowledgement | 22 |



This page is intentionally left blank.

In-flight non-intrusive measurement of wing dynamics and of the aileron and flap deflection and deformation

Henk W. Jentink¹, Pavel Růžička², Henk P.J. Veerman¹, Jan H. Breeman¹

¹ Netherlands Aerospace Centre NLR, The Netherlands

Email: henk.jentink@nlr.nl, henk.veerman@nlr.nl, jan.breeman@nlr.nl

² EVEKTOR, Czech Republic

Email: pruzicka@evektor.cz

1. ABSTRACT

New measurement capabilities are provided for in-flight aircraft wing deformation applying the Image Pattern Correlation Technique. The motion of the wing and of the movable parts of the wing can be determined relative to a reference form with high spatial resolution, bandwidth and accuracy. Instrumentation comprises a video camera and a speckled pattern on the wing section under investigation making the installation easy. The technology to determine the deflection and deformation of an aileron and the capability to measure wing dynamics is presented. Flight test campaigns were flown with the EVEKTOR Cobra and the NLR Fairchild Metro II to investigate the measurement capabilities. The results demonstrate that the IPCT method is promising for application in flutter tests, that dynamic features of the wing can be measured and that the aileron deflections and deformations can be measured. Finally a software tool providing a Graphical User Interface (GUI) was developed to improve the efficiency of applying IPCT further and to improve the user friendliness. The GUI guides Flight Test Engineers through the processing of images in an interactive manner.

2. INTRODUCTION

A method was developed for measuring wing deflection and deformation using a speckled pattern on the wing and a video camera in the cabin of the aircraft. The Image Pattern Correlation Technique (IPCT) for in-flight wing measurements has been reported in previous SFTE-EC symposia, see [1] and [2]. IPCT is a powerful technique

to measure wing deformations as the instrumentation is easy to apply on the aircraft and results have high resolution, can have high bandwidth and are very accurate.

The method is now extended to the measurement of the deflection and deformation of rotating surfaces on the wing. The method was applied on the NLR Fairchild Metro II and the EVEKTOR Cobra.

IPCT uses randomly speckled patterns on the measurement surface that are observed by cameras imaging the speckles from different viewing angles. IPCT is mostly based on principles used in Particle Image Velocimetry (PIV) [3]. The technique in more general terms is also known as Digital Image Correlation (DIC) [4], [5]. Correlation software determines the displacements for groups of speckles, the interrogation areas, using the geometry of the camera setup.

The correlation of speckled parts on the image of the aircraft wing enables the measurement of the deformation of that part of the wing. The aircraft environment poses special challenges and sets constraints on how the technique can be applied. The options for installing instrumentation are limited if installation of cameras inside of the cabin is chosen. Installation outside of the cabin requires a much larger effort and downtime for the aircraft. The slant viewing angles connected to the camera installation in the aircraft introduce a challenge. Installing two cameras in the aircraft with a good view on the measurement areas and an adequate baseline between the cameras adds to the challenges. The application of IPCT for the aircraft environment has been developed in the projects AIM (Advanced In-flight Measurement techniques) and AIM² that were supported by the European Commission. The application of image correlation based on images of two cameras in a stereoscopic setup, as well as the application of images of just one camera in a monoscopic setup, was developed within the AIM and AIM² projects [6]. This paper will focus on the application of the IPCT technique with one camera. The installation for such measurements is easier because installation of just one camera is needed and one viewing angle on the area under investigation is involved. The price one pays is that the geometry of the aircraft has to be accurately known and is to be included in the processing of images. The stereoscopic version needs two cameras installed with a significant baseline and difference in the viewing angle of the area under investigation. Geometrical data of the aircraft is less important for the processing. A calibration of the camera set-up, normally executed by recording images of a test board with grid lines, is needed [3], [6].

In the AIM and AIM² projects the techniques have been applied both on research aircraft and on prototype aircraft of aircraft manufacturers. The aircraft of which surfaces have been measured ranges from gliders like the PW6, to the sports aircraft Evektor Cobra, to the business aircraft Piaggio P190, to the small airliner aircraft Fairchild Metro II, to the wide body aircraft Airbus A320 and Airbus A380 [2], [7].

The direct application of IPCT for rotating surfaces such as the aileron, flap and rudder, will not work accurately if the rotation is more than typically a few degrees. The applied correlation of patterns will not work anymore as the correlation only searches by translating the pattern. Measuring with IPCT the rotation, displacements and deformation of the movable parts which are used for controlling the aircraft (aileron, rudder) and for increasing the aerodynamic lift of the wing (flap, slat) has large benefits over traditional techniques as the traditional techniques require more complicated instrumentation. An IPCT method for deflection measurement is discussed in this paper. The method applies a transformation of the part of the reference image containing the moving component. The transformation corresponds to a rotation over an estimated angle of the object image as an intermediate step before the correlation of this transformed reference image with the measurement image for an exact deformation measurement.

State-of-the-art cameras nowadays offer large resolution and a considerable number of images per second. This suits very well with the needs for aircraft flight tests to measure the wing and aileron deflections accurately and with high temporal resolution. In the qualification and certification process of an aircraft important flight tests campaigns are dedicated to measuring the wing vibration in flight. Flutter conditions should be identified and prevented. This paper shows that the wing vibrations can be measured with sufficient bandwidth for these investigations.

A software package including a Graphical User Interface (GUI) was developed in order to enable efficient processing of images. The interface guides an engineer to just input some aircraft geometry and images in the software tool which will be processed, resulting into deflection parameters and deformation fields. The processing algorithm and software tool are described.

3. METHODOLOGY FOR DETERMINING WING DEFORMATION

3.1. Wing deformation

The deformation of the speckled part of a wing can be related to the displacement of speckles in the image of the wing. With one camera the displacement can only be monitored in two dimensions. The displacement of the speckles on the main wing relative to a camera installed in a cabin is primarily due to heave and torsion of the wing; no displacement in spanwise direction is expected. The motion is therefore limited to two dimensions. The direction is guided by the structure of the wing, is well defined and in general close to perpendicular to the surface near the main spar of the wing.

The displacement of the speckles in the image plane of a camera is related to a translational and angular displacement which depends on the focal length of the applied

lens and the distance between the lens and the wing area under investigation. The angular displacement and the displacement in motion direction are related as:

$$\Delta s = d \Delta\varphi / \cos\theta$$

where

Δs = displacement of the speckles

d = distance between the camera and the speckles

$\Delta\varphi$ = angular displacement measured by the camera

θ is the angle between the direction of the motion of the speckles and the line between the camera and the speckles

The distance between the camera and the speckled area is given by the geometry of the aircraft and this is an important parameter for the one-camera method described in this paper.

The speckles on the wing do not all show the same displacement because of the flexibility of the wing. Speckle displacements are determined for small groups of speckles in the pattern that have almost identical displacements. Experience, also gained in applying Particle Image Velocimeter (PIV) [3], indicate that the grouping of speckles in so-called “interrogation areas” can be optimized to having typically 10 speckles or more. Furthermore experience indicates that speckle size should be chosen optimally as being imaged on 1.6 times the pixel size on the camera sensor. For IPCT on aircraft wings such optimizations give the requirements for an optimal speckle pattern on the wing. Due to the slant viewing angle to the surface the speckle optimization results in elongated speckles and markers, see Figure 1. The fitting of the displacements of speckles in the interrogation areas over the whole speckled wing area provides the heave and torsion of the wing. Subtracting these global wing-related displacements yields the local surface deformations.

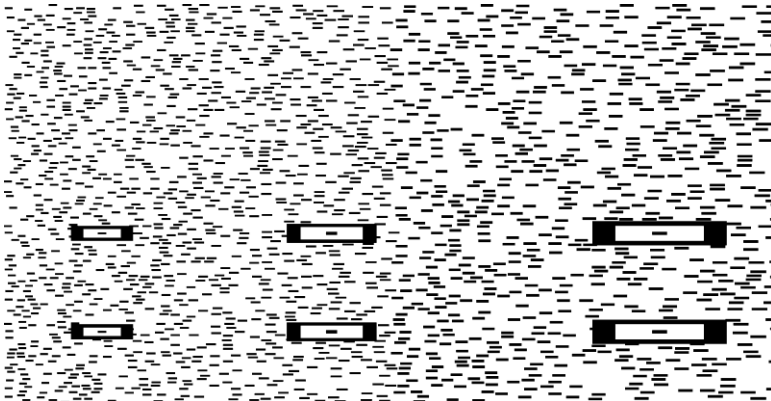

Figure 1 Speckle pattern applied on the aileron of the Metro

Markers are depicted to the speckled area in addition to the speckles for a first coarse estimate of displacements and as position references on the wing. This tracking of displaced markers in the image is applied as a first step in the IPCT processing algorithm giving guidance to expected speckle displacements for the interrogation areas. Correlation functions around these first estimates are determined for the speckle pattern in each interrogation area. Subsequently correlating the interrogation area led typically to 0.2 pixel correlation accuracy under in-flight conditions. For the flight demonstrations described in this paper this leads to an accuracy of 0.3 mm and 0.4 mm at 5 m distance. This is determined by the focal length of the lens, 50 mm for the Metro measurements respectively 35 mm for the Cobra measurements, and the camera pixel size, 0.0142 mm. The actual quality of the image, i.e. reflections of sun light or clouds on the surface and blurriness of images due to shock or vibration is the major factor of measurement accuracy reduction. Depth of field induced blur was very low by taking advantage of closing the diaphragm under sunny conditions.

3.2. Deflection and deformation measurements on movable parts of the wing

The movable parts of the wing, i.e. the aileron, the flap and the slat, have a motion component that is common to the wing, but also additional rotational and sometimes translational motion components. As standard cross correlation technique was proven to work in practice up to a rotation angle of a few degrees only it was decided to adapt the algorithm for the rotating parts of the wing. The displacement of the rotation axis is first determined from the IPCT processing of the fixed part of the wing close to the rotation axis. Then a first estimate of how much the part was rotated was made from markers displacements. Then, the part of the reference image corresponding with the rotating part is transformed such that it corresponds with a rotation of the speckles over that estimated angle. In practice this is a delicate procedure, because the rotation axis of the rotating part must be determined accurately in the reference image. In a next step the transformed reference image part of the speckled wing pattern is correlated with the measurement image. Rotations still to be assessed after the estimation of rotation from

marker displacements appear to be within the range in which correlation works well. The correlation also yields a small adjustment to the rough estimate of the rotation of the rotating part; this can be used to repeat the above procedure for additional accuracy.

4. INSTRUMENTATION OF THE AIRCRAFT

A pattern with randomly distributed speckles was fixed to the surface of the wing of the aircraft. The speckle size and the focal length of the lens on the camera were chosen such that the image of the pixel covers 1.6 x 1.6 up to 2 x 2 pixels on the camera sensor. The spanwise size of the speckle was larger than the chordwise size of the speckle to correct for the slant viewing angle of the speckles. This ensures that the speckles are square in the image. The speckle size was proportional with the distance between speckle and camera sensor to keep the size of the speckles constant everywhere in the image. The last parameter to be defined for the speckled pattern was the speckle density. 15 % area coverage of speckles was applied, being a value giving good results. As mentioned, markers were added to the image for guiding the correlation algorithm. All of these parameters have been included in a software program that generated the pattern. The user interface and a result are shown in Figure 6.

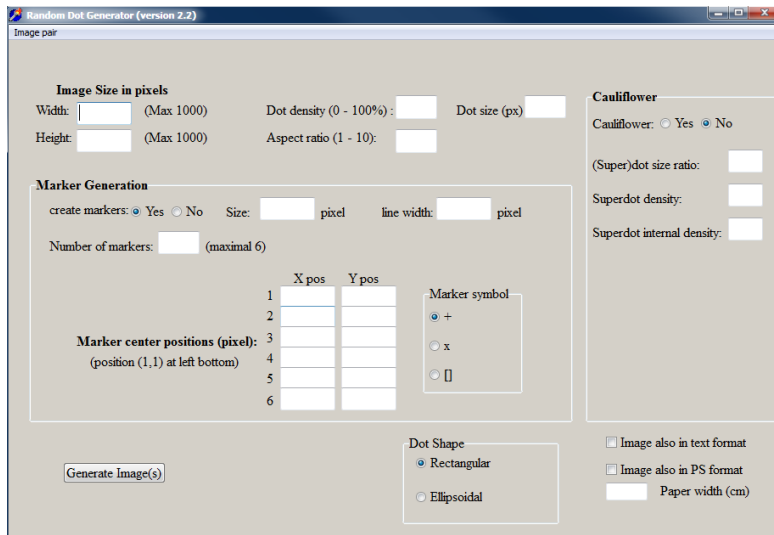

Figure 2 Graphical User Interface for the programme that generates speckle patterns for IPCT

Stickers with the speckle pattern were purchased. The sticker material and the method for sticking have been qualified for the in-flight conditions as the aerodynamics of the wing is not to be impacted. Aerospace qualified products in combination with attention to where the stickered area starts on the wing provided for secure solutions.

The camera viewing the speckled area was installed in the cabin of the aircraft. Measurements of the speckle displacements were made relative to the camera's

position and viewing direction. As the aircraft may experience large accelerations and rotation rates during flight test, a stable installation of the camera in the cabin is very important. Therefore stiff mounting frames were made for the cameras fixing the cameras rigidly on the seat rails of the aircraft.

Two high-speed, high resolution AOS type S-EM cameras were installed in the cabin of the aircraft viewing the speckled areas on the wing, the flap and the aileron. The reason for installing two cameras was to enable also stereoscopic IPCT processing and in addition it gives the opportunity to check measurement results of one camera with those of the other camera. Dynamic measurements were enabled by applying these AOS cameras. Image streams from each camera sensor were recorded on solid state memory inside the camera for later download on a laptop in the aircraft. Synchronisation between camera images and the aircraft measurement system was established within a millisecond based on a GPS-slaved IRIG-B time code generator. A frame rate of 120 images per second was chosen. This rate is much higher than needed for measuring the main vibration modes of the aircraft, which are below 10 Hz. The data generated with the high-resolution cameras (1280×1024 pixel²) were taken in runs of 8 seconds duration.

4.1. Fairchild Metro II

Starting from the status obtained by the predecessor AIM project [1] in-flight IPCT was further developed in AIM² for measuring deformations of dynamically moving surfaces and for measuring the deformations of the rotating flap and aileron surfaces. A flight test campaign was flown with the NLR Fairchild Metro II to test the developed measurement method and processing algorithms. Right wing sections between 2.35 m and 4.75 m i.e. parts of the aileron, the flap and part of the main wing adjacent to the flap and aileron were covered with speckled sticker material, see Figure 3.

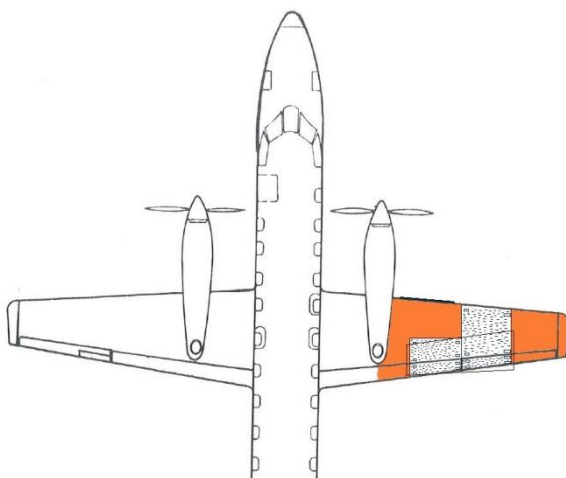

Figure 3 Indication of the location of speckled pattern on the NLR Fairchild Metro II

Figure 4 shows the measurement setup on the wing and in the cabin. The aircraft was also equipped with a Honeywell HG1050 Inertial Reference System (IRS) to measure the motion of the aircraft, a Honeywell Digital Air Data Computer (DADC) measuring the aircraft airspeed and the angle of attack, a GPS receiver for position measurement, a synchro measuring the aileron rotation angle and a potentiometer that measured the flap rotation. This aircraft data was recorded and stored on a ruggedized PC based recording system during the test flight, while the image stream of the cameras were recorded on dedicated laptops. The amount of fuel in the tanks of the aircraft was noted during each run by the non-flying pilot for determining wing loads in post-processing.



Figure 4 Pictures of the interior of the NLR Fairchild Metro during the AIM² flight test (left) and of the starboard wing of the aircraft with the partly speckled wing, aileron and flap (right picture)

4.2. Evektor Cobra

The instrumentation of Evektor Cobra was similar to the instrumentation of the Metro. The installation of identical cameras on a frame in the cabin and the speckled pattern taped to the wing is shown in Figure 5. As the investigation for the Cobra was especially for wing vibration and the related wing flutter investigations also accelerometers were installed on the wing. Aircraft attitude, control surface position and location were measured with a similar instrumentation package as was installed on the Metro.



Figure 5 EVEKTOR Cobra with a speckled pattern taped on the left wing and cameras installed in the cockpit

5. PROCESSING OF IMAGES

The algorithms described above to process images towards wing deformation information were programmed in a Matlab software package. To make the processing of images easy for Flight Test Engineers the Matlab code was embedded in a GUI which guides the user through the process of defining geometrical information of the area that is processed on the wing, such as dimensions and the wing profile, processing parameters and requested outputs, see Figure 6. The deformations of the wing area can be modelled in generic parameters such as wing heave, dihedral, torsion, twist and curvature.

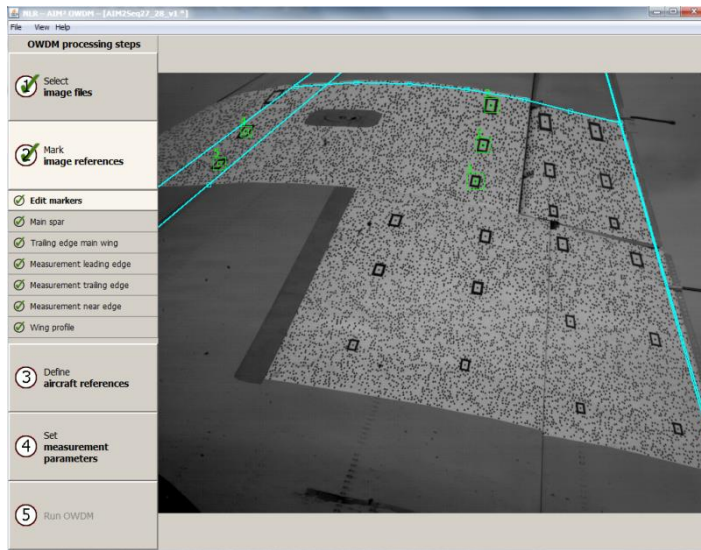

Figure 6 One of the screens of the GUI for IPCT processing of wing images. In the left column the steps for processing the images are given

6. MEASURING WING DEFORMATION DYNAMICS

Applying cameras that acquire a large number of images per second compared with the dynamics of an aircraft wing provided the potential for flutter measurements and other dynamic investigations on the wing. The capability was demonstrated by measuring the wing deflection just before, at and after the landing of the Metro and by ground measurements of Cobra wing vibrations.

6.1. Landing

Figure 7 shows the heave measured with IPCT during a touch-down at Woensdrecht Airport. The vertical acceleration as measured with the IRS (positive upwards) in the cabin of the aircraft is also presented in Figure 7. Measurements are synchronized and the touch-down moment was obviously at 3.5 seconds after the start of the run.

As can be seen in Figure 7 the heave of the wing before touch-down is larger than after touch-down. The wing generates less lift after touch-down as the aircraft has weight on its wheels and that is clearly reflected in this measurement. The loss of lift at the touch-down is of course due to the decrease of the angle-of-attack as the nosewheel is lowered on the runway.

The wing movement measured with IPCT is much more complex than the acceleration measured with the IRS. This is partly due to the bandwidth of IPCT (60 Hz) versus the more limited bandwidth of the IRS (8 Hz), partly due to motion of the wing relative to the fuselage and probably partly due to camera vibrations. A response of the wing on the initial acceleration is visible in Figure 8. The modes of the wing deformations are clearly visible in the frequency range from 0 to 10Hz. A strong vibration of about 37 Hz is also

visible in the heave measurement, probably due to the limited stiffness of the camera mounting. The installation of the cameras stiffly enough to sustain all loads experienced in aircraft predictably is to be improved or a correction method for camera motion such as reported in [2] is to be applied.

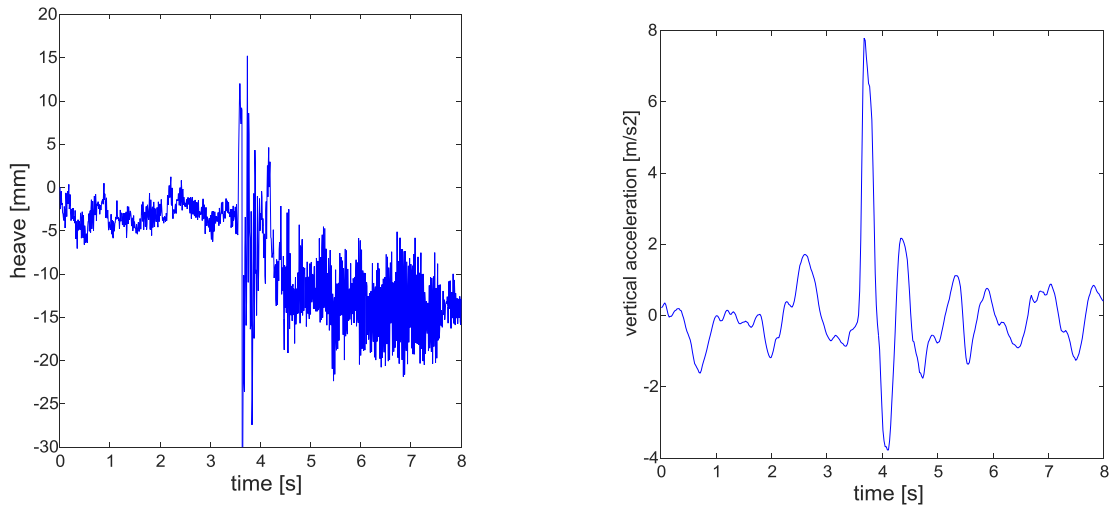

Figure 7 Wing heave, measured with IPCT (left) and the vertical acceleration in the cabin of the aircraft, measured with the IRS (right, positive upwards), during touch-down at Woensdrecht Airport

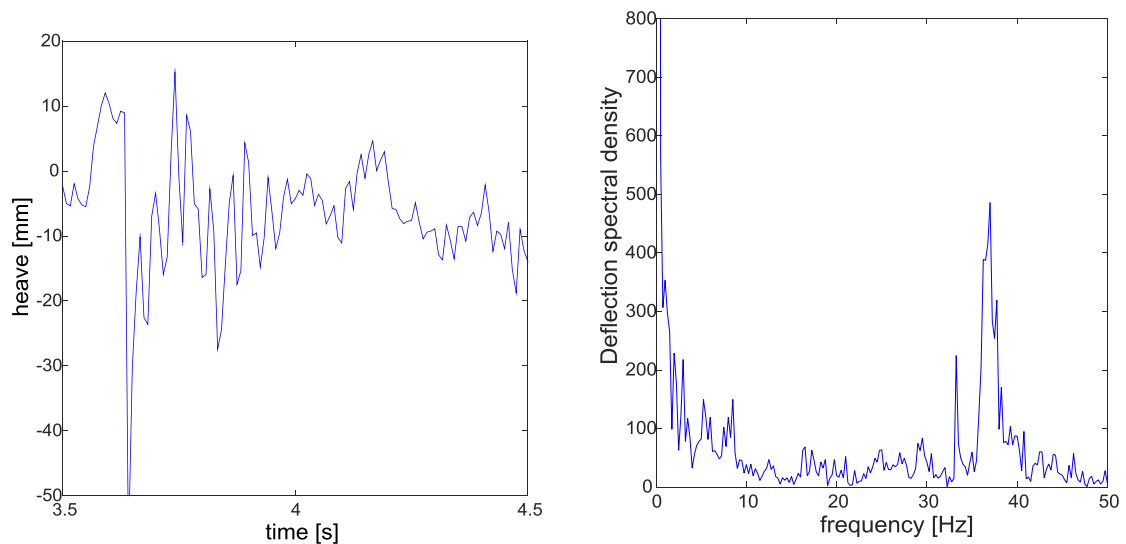

Figure 8 Zoom in on the heave and the spectral density of deflections. The wing motions are in the frequency range up to 10 Hz

6.2. Wing vibration measurement

The Cobra wing was mechanically excited on the ground while on struts by hitting the wing with a hammer. IPCT wing vibration measurements of the wing containing fuel and with an empty tank are presented in Figure 9. The vibrations were also measured with accelerometers resulting in spectra that were in agreement with the spectra measured with IPCT. Ground vibration measurements are the first measurements performed for a flutter investigation and these results show that the measurement setup can be used for this purpose.

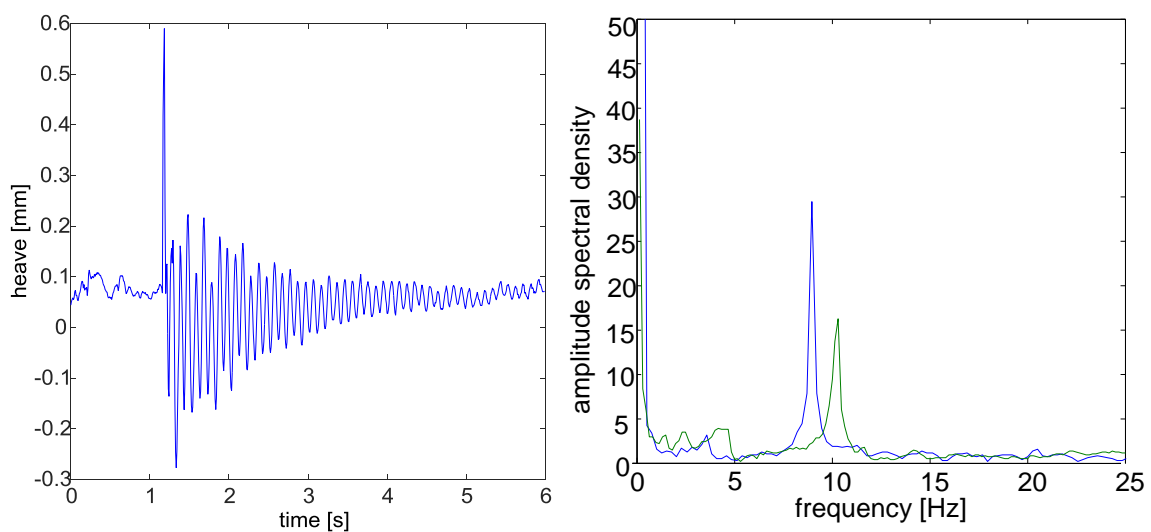

Figure 9 Vibration of the Cobra wing on the ground as a function of time for the wing after an impulse with a hammer (left) and the Spectral Density of the amplitude of wing vibrations (right) after hitting the wing with (blue line) and without fuel (green line)

In the flight test it was also attempted to measure the damping of the wing vibration at different airspeeds by hitting the steering wheel. The damping was so high that the response did not show any periodic behavior at airspeeds that were allowed during this campaign.

7. IPCT FOR MEASURING AILERON AND FLAP DEFLECTIONS AND DEFORMATIONS

Matlab software was developed to analyse the image part of the rotating aileron or flap. The rotation of the aileron and flap relative to a hinge axis and deformations were measured. Determining the 3D location and orientation of the rotation axis appeared to be challenging. The rotation axis has to be defined accurately, both geometrically and its projection in the image. Not only for its stable position on the ground but also in-flight when the axis moves due to wing deformation. The axis is located underneath the wing surface, resulting in a combination of a translation and rotation of speckles on the

surface. Accurate 3D co-ordinate descriptions of the wing, the axis, the flap and the camera, both in the geometrical domain and the image domain were developed and the transformations between the geometrical and image domain were defined.

The first processing step is the determination of the geometric displacement and rotation of the rotation axis. This is done by performing IPCT analysis of the wing surface and extrapolating the estimated deformation model to the position of the rotation axis.

The second step is a first estimation of the rotation angle of the wing part (flap or aileron) made by analysing the displacements and rotation of the markers on the wing part in the image. For larger rotations also tracing of the markers in the image was hampered. The tracing was based on correlation of relevant areas around the marker that were defined in the IPCT algorithm (and therefore also in the GUI). Square markers were applied on the Metro and the Evector that changed in diamond shapes in the image when the aileron or flap was rotated. Correlation functions of square markers and diamond markers do not have an optimally defined peak and therefore this step might be improved by applying other marker shapes in the future.

In the third processing step the image part showing the rotated surface in the reference image is rotated over the angle estimated in the second step using the full 3D geometric transformation formulas. However these formulas are complex and therefore time-consuming for the calculations. Therefore this step was simplified in order to keep calculations fast. The measurement area under investigation on the aileron or flap is subdivided in a 2D geometrical grid defining smaller areas of interest. Only for the corner points in the grid, the full 3D geometric transformation formulas are applied. The translations of the image pixels lying between the grid points are calculated using 2D interpolation between the neighbouring grid points. The pixels of the resulting transformed image no longer coincide with the original location of the camera pixels. This is corrected using a 2D linear interpolation algorithm. The final result of this step is a transformed reference image that presents the view of the rotated part as it should look as a result of the wing deformation and the estimated rotation of the part.

In the fourth and final step the transformed reference image is correlated with the measured image using the IPCT algorithm, yielding a deformation model for the rotated part and the deviations from the reference model of the individual areas of interest. This is exactly the same procedure that was described earlier for the wing surface. The deviations calculated during this step also yield an improved estimate for the rotation angle of the wing part. This estimate can be used to improve the IPCT results by restarting the calculations from the third step.

Developing the measurement process and the associated algorithms was found to be not trivial. Especially accurate determination of the rotation axis of the aileron or flap in the images and the related accurate definition of wing, surface and rotation axis geometry proved to be essential. Small deviations appeared to have considerable effects on the result of the measurement in cases where the process was not well controlled or when geometries were not well defined.

The next section presents the results from in-flight aileron deflection and deformation measurements. For aileron and flaps deflection and deformation the same algorithm can be applied.

7.1. Aileron deflection and deformation measurements in flight

During the flight test campaign with the EVEKTOR Cobra aileron deflections were measured with IPCT. An aileron doublet manoeuvre gave a range of aileron deflections that were processed.

The processing result of images taken during the doublet manoeuvre is shown in Figure 10. Note that the motion is very smooth, where the measurements are the result of correlations of different measurement images vs. the reference image. Variations in the measurements are very small. In periods with minimal aileron motion the standard deviation of the IPCT measurement is 0.016 degree, giving an indication of the lower bound on the error of the IPCT measurements.

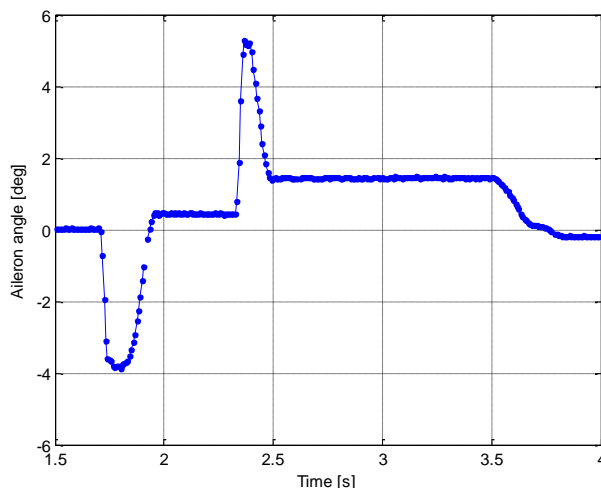
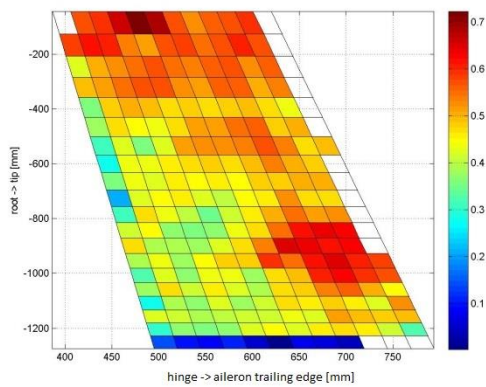

Figure 10 Aileron deflection measured with IPCT during the doublet manoeuvre in Cobra flight test campaign

The image processing algorithm determined the deformation of surfaces in terms of heave, dihedral, rotation, torsion and chordwise curvature fitting the best smooth surface through the measurements. The residue after fitting this smooth surface will

consist of the local deformations of the surface and the residual measurement errors. These residues are presented in Figure 11.

The residual vertical deformations appear to have a coherent structure. The position in the lower left corner (500 mm, -1200 mm) is more stable, i.e. smaller deformations, than the rest of the aileron. Furthermore the residual deformations at two locations on the aileron (650 mm, -900 mm) and (650 mm, -400 mm) are larger than the surrounding aileron surface. This corresponds with the mechanical design features of the aileron as is shown in Figure 12.



Aileron deflection is -0.02 deg.

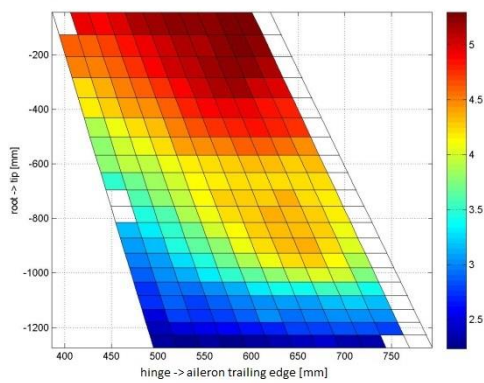

Aileron deflection is +3.90 deg.

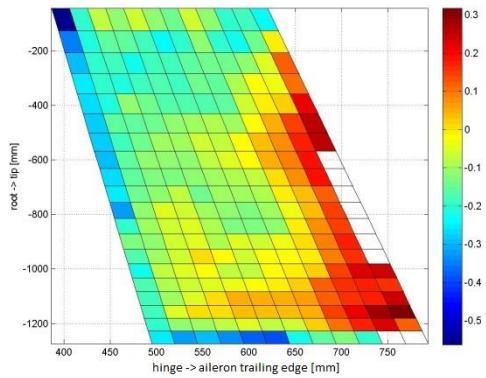

Aileron deflection is -0.49 deg.

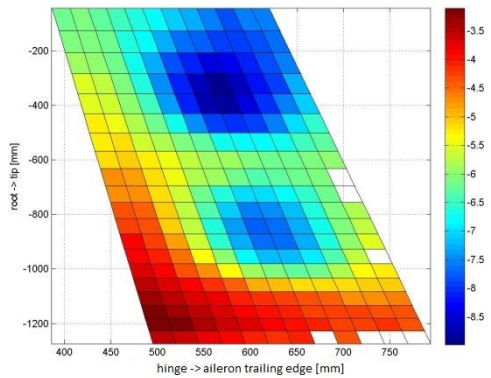

Aileron deflection is -5.47 deg.

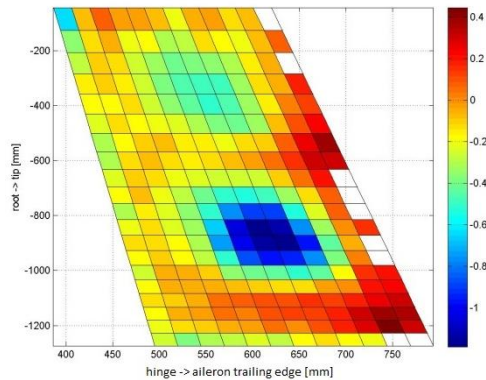

Aileron deflection is -1.46 deg.

Figure 11: Residual aileron deflections in mm after correlating the measurement images with the optimally rotated reference image. The co-ordinates are with the y-axis on the center of the main spar of the wing and the x-axis perpendicular to the y-axis on the wing surface. The origin ($x=0$, $y=0$) of the coordinate system is chosen on the main spar, at the tip of the wing

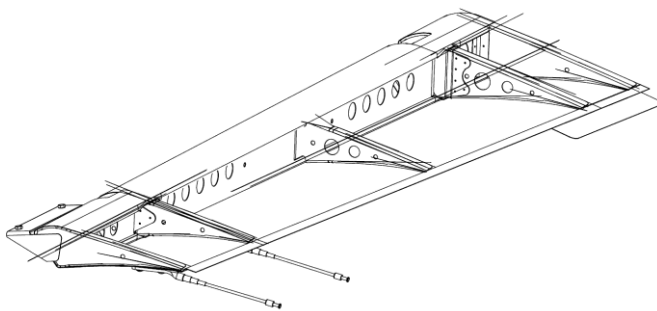

Figure 12 Drawing of the internal structure of the EVEKTOR Cobra aileron

8. CONCLUSION

IPCT, a new technique for measuring the wing deformation, requires a small installation effort for the instrumentation and provides high bandwidth, high resolution and accurate results. The technique can be applied for the movable parts of the wing where both the deflection of the surface and the deformation can be determined. Demonstrations for in-flight measuring the aileron deflection and deformation and for measuring wing dynamics were presented.

For applying the IPCT technique with one camera geometrical information is used of the camera position relative to the measurement areas and the direction of the deformation. This information is either available or can be measured on the ground.

For determining the deflections of movable parts of the wing the rotation axis has to be determined both geometrically with respect to the camera and in the images to be

processed. As the rotation axis moves together with the wing this has to be determined per processed image. The accuracy for determining the axis is critical for accurate deflection information of the control surface.

Deflections of the wing were measured on the ground and in-flight with a bandwidth suited for flutter investigations. The measurement of eigen frequencies of the wing with IPCT and accelerometers on the ground are in agreement. Excitation of vibrations in-flight by hitting the steering wheel was not sufficient for flutter investigations at the airspeeds flown.

The installation of the cameras stiffly enough to sustain all loads experienced in aircraft predictably or to be able to correct for camera motion needs further development. This will make the method suitable for amongst others flight flutter tests.

A software tool providing a Graphical User Interface was developed for applying IPCT image processing easily. A Flight Test Engineers with a basic knowledge of the technique and the measurement goals should be able to process images in a short time into plots and time traces of wing parameters.

9. REFERENCES

- [1] H.P.J. Veerman, H. Kannemans, H.W. Jentink, "High Accuracy In-Flight Wing Deformation Measurements based on Optical Correlation Technique", NLR-TP-2008-718, Proceedings 19th SFTE (EC) Symposium, Manching, EADS, Germany, paper 3-2, 22-24 September 2008
- [2] F. Boden, T. Kirmse, T. Weikert, T. Wolf, C. Petit, H.W. Jentink, "Application of a new optical measurement technique for non-intrusive wing deformation measurements on a large transport aircraft", Proceedings 21st SFTE (EC) Symposium, Vergiate, AgustaWestland, paper 4, 3-6 October 2010
- [3] Image Particle Velocimetry, a practical guide, M. Raffel, C. Willert, S. Wereley, J. Kompenhans, Springer-Verlag, 1998, 2007
- [4] Digital Image Processing, W.K. Pratt, Wiley Interscience Publication, 1991
- [5] Three-Dimensional Displacement Measurements using Digital Image Correlation and Photogrammic Analysis, Z.L. Kahn-Jetter, T.C. Chu, Experimental Mechanics, March 1990, Volume 30
- [6] F. Boden, N. Lawson, H.W. Jentink, J. Kompenhans, ed. "Advanced In-Flight Measurement Techniques", Springer, Berlin Heidelberg, ISBN: 978-3-642-34737-5 (Print) 978-3-642-34738-2 (Online), 2013
- [7] C. Petit, H.W. Jentink, F. Boden, H. Kannemans, H.P.J. Veerman, T. Kirmse, "Introducing a new measurement method for wing twist and bending", Proceedings ETTC 2009, Toulouse, France, 24-26 June 2009



Acknowledgement

The research and development leading to these results was part of the Advanced In-flight Measurement Techniques 2 (AIM²) project which was partly funded by the European Commission within the 7th framework program (contract No. ACP0-GA-2010-266107).