



NLR-TP-2002-271

Development of a Mechanically Pumped Two-Phase CO₂ Cooling Loop for the AMS-2 Tracker Experiment

A.A.M. Delil, A.A. Woering and B. Verlaat



NLR-TP-2002-271

Development of a Mechanically Pumped Two-Phase CO₂ Cooling Loop for the AMS-2 Tracker Experiment

A.A.M. Delil, A.A. Woering and B. Verlaat*

* National Institute for Nuclear and High-Energy Physics NIKHEF, The Netherlands

Presented as SAE-2002-01-2465 during the 32nd Conference on Environmental Systems, at San Antonio, TX, USA, 14-18 July 2002.

Part of the reported work has been carried out under contract for the Netherlands Agency for Aerospace Programmes.

The contents of this report may be cited on condition that full credit is given to NLR and the authors

Customer: National Aerospace Laboratory NLR
Working Plan number: R.1.A.1
Owner: National Aerospace Laboratory NLR
Division: Flight
Distribution: Unlimited
Classification title: Unclassified
May 2002



Contents

ABSTRACT	3
INTRODUCTION	3
TRADE-OFF: CO₂ MPL AS TTCS BASELINE	4
TTCS CONCEPT	5
TEST SET-UPS AND TEST RESULTS	6
FULL SCALE TEST RIG	8
THERMAL MODELLING	8
IN-ORBIT EXPERIMENTS & CONCLUSION	8
NOMENCLATURE	9
REFERENCES	10
CONTACT	10

12 Figures

(10 pages in total)



2002-01-2465

Development of a Mechanically Pumped Two-Phase CO₂ Cooling Loop for the AMS-2 Tracker Experiment

A.A.M. Delil & A.A. Woering
National Aerospace Laboratory NLR, The Netherlands

B. Verlaat
National Institute for Nuclear and High-Energy Physics NIKHEF, The Netherlands

Copyright © 2002 Society of Automotive Engineers, Inc.

ABSTRACT

The Alpha Magnetic Spectrometer AMS-2 is planned for a five years mission as attached payload on ISS, the International Space Station. It is an international experiment searching for anti-matter, dark matter, and missing matter. AMS-2, an improved version of AMS-1 flown on STS 91, consists of various particle detector systems, one of these being the (Silicon) Tracker. The trade-off based choice and the experimental feasibility demonstration of a mechanically pumped two-phase CO₂ cooling loop for the Tracker is discussed in detail. The current status and ongoing and planned development activities are discussed.

INTRODUCTION

The international Alpha Magnetic Spectrometer experiment AMS [1] is a particle detector for high-energy cosmic rays. It consists of several sub-detectors: The (Silicon) Tracker, the Time of Flight (ToF) system, the Veto Counters, the Transition Radiation Detector (TRD), the Synchrotron Radiation Detector (SRD), the Ring Imaging Cherenkov Counter (RICH), and the Electromagnetic Calorimeter. The detectors operate in a magnet field generated by a super-conductive magnet, which is responsible for curving the particle tracks necessary for charge identification. Its scientific goal is to detect anti-matter, dark matter and lost matter. The project leader is Nobel Prize laureate S.C.C. Ting of the Massachusetts Institute of Technology. The collaboration, supported by the US Department of Energy and NASA, includes about 40 participants from (all over the world) academia and research institutes [1]. AMS-1, containing a very heavy solid permanent magnet instead a super-conductive magnet, was a demonstration flight on STS-91. Figure 1 depicts the experiments in the AMS-2 configuration.

The thermal issues of AMS-2 are far more demanding and critical than in AMS-1, because of the replacement of the heavy (high thermal capacitance) magnet by a liquid Helium cooled super-conductive one, and by the

very long (five years) mission duration. Therefore a team consisting of NLR, NIKHEF, INFN Perugia and the University of Geneva started early 2000 to develop a cooling system for the most critical part, the Tracker, the so-called TTCS (Tracker Thermal Control System).

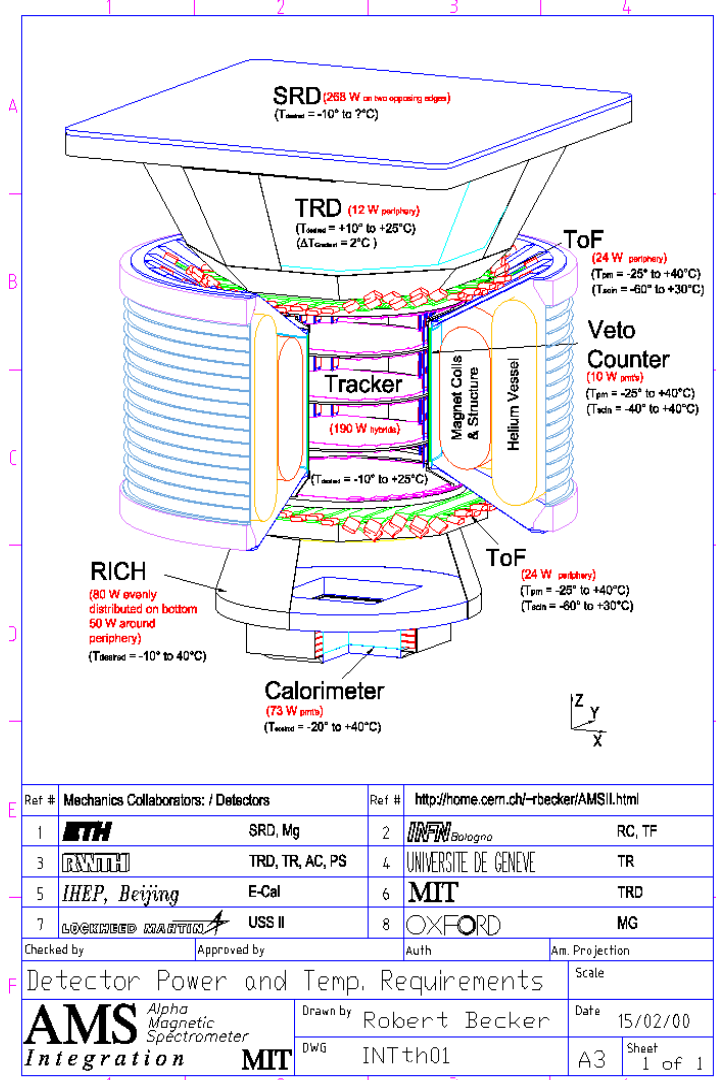

Fig. 1: The Different AMS Experiments.



TRADE-OFF: CO₂ MPL AS TTCS BASELINE

The AMS-Tracker, located inside the vacuum case, is surrounded by the cryogenic magnet, which is not allowed to receive any heat from inside. Moreover the Tracker has severe requirements with respect to spatial and temporal temperature gradients. This and the existing complicated three-dimensional configuration, requires that the power dissipated in the Tracker (192 W) has to be removed to two thermally out of phase radiators (one in RAM, one in Wake direction) to be dumped into space. This could be done by a mechanically pumped two-phase loop system, by a mechanically pumped liquid loop and by a capillary pumped loop system. The latter system requires heat collecting heat pipes to transport the dissipations from the silicon front-end electronics to the capillary system, as a capillary system can't properly handle evaporators (heat sources) in series. In addition, a parallel capillary system [2, 3] leads to unacceptable tubing length and mass, which can't be accommodated by the existing 3-D Tracker configuration. Finally it is remarked that the chosen system has to be installed two-fold to guarantee the full redundancy required.

The silicon wafer thermal requirements are:

- Operating temperature -10 to +25 °C (263-298 K)
- Survival temperature -20 to +40 °C (253-313 K)
- Temperature stability 3 k per orbit
- Maximum gradient between any silicon: 10 K
- Dissipated heat 2.0 W End Of Life

The hybrid circuit thermal requirements are:

- Operating temperature -10 to +40 °C (263-313 K)
- Survival temperature -20 to +60 °C (253-333 K)
- Dissipated heat 192 W total, 1 W per hybrid pair

Keeping the above in mind and following in the next the references 3 and 4, it can be said that:

- The series configuration two-phase Mechanically Pumped Loop (MPL) is compatible with existing Tracker hardware. It is characterised by minimal material inside or near the tracker field of view. It is directly connected to the thermal bars, hence no additional heat collector needed. Multiple source heat input is possible, with minimum T-gradients (< 1 K). It has also the possibility to implement a fully redundant system. Costs and mass are relatively low. The only drawback is the presence of a mechanical pump.
- A Single-Phase (liquid) Mechanically Pumped Loop (SPL) has more or less the same layout as the MPL option, so it is relatively easy to fall back on the SPL solution, in case of unforeseen (serious) problems with the MPL development. It has the possibility of parallel and counter-current flow system set-up. It is a low-risk design, as there is sufficient experience in space with SPL's. Main drawbacks are the far larger temperature gradients (say 10 K), as compared to the nearly isothermal MPL, and larger dimensions.
- Any parallel two-phase system (MPL, LHP or CPL) is not capable to accommodate the existing Tracker hardware (multiple location heat input), by it self in one

stage, because of the huge mass and (not available) space needed, especially in case of redundancy. In a two-stage approach, an additional heat collector is needed: A heat pipe or a high conductivity TPG-flange. But this induces significant mass increase and also serious integration problems.

The above makes obvious that by far the best solution is the series two-phase MPL. A parallel or hybrid SPL is a possible back-up solution, but at the cost of more massy and lengthy lines and larger pumps. Parallel concepts are non-recommendable or impossible solutions.

CO₂ has to be the working fluid since:

- It is considered to replace Freon-like refrigerants, as it is environment friendly and non-toxic. It is used for nuclear power plant cooling, as it is inert for radioactive radiation. For AMS-2 this means no ISS safety-related problems.
- It has a very low liquid/vapour density ratio, Order (1-10), being profitable for a series 2-phase system; its alternative, ammonia: Order (10²-10³).
- CO₂ experience was gained at NIKHEF, where tests have proven the concept feasibility of CO₂ cooling for the LHCb Vertex detector [5]. For the TTCS this means small tube dimensions (3 mm OD) in case of 2 loops, temperature drops < 1 K and pumping power < 10 W.

In addition it is remarked that [4]:

- The basic difference between mechanically pumped single-phase (caloric heat transport by the liquid) and two-phase systems (transport by latent heat of evaporation/condensation). This implies for dissipating stations in series in a single-phase system a temperature increase in the downstream direction of the loop. For two-phase systems, with evaporators in series, it means an increase of the vapour quality in the downstream direction, accompanied by a (usually small) decrease of the saturation temperature.
- In mechanically pumped two-phase loops, the flow pattern dependent heat transfer coefficient for convective flow boiling is reported to be between say 4 and 5 kW/m²K [6]. This is not true for refrigerants (to be used in the TTCS) at qualities below 0.15 for which the value can increase to say 20 kW/m².K at qualities of less than 0.03 [6, 7]. Data from experiments with CO₂ in small diameter tubes confirm this [8]. The above implies that a mechanically pumped system has to be designed such that any evaporator exit quality is below 0.15 (preferably even much lower) for efficiency reasons.
- In the case of very lengthy mechanically pumped two-phase loop lines the pressure (saturated temperature) gradient has to be kept small to guarantee a small end-to-end pressure (saturated temperature) difference to meet the requested isothermality, and to keep the evaporator exit vapour quality below 0.15, as in flowing refrigerants the vapour quality usually increases with pressure decay [9]. Ethane is an exception, showing vapour quality increase below say 0.7, decrease above this value.



In conclusion it can be said that a dedicated hybrid two-phase loop configuration, as it is schematically depicted in figure 2, will guarantee both the required isothermality and the preferred quality range.

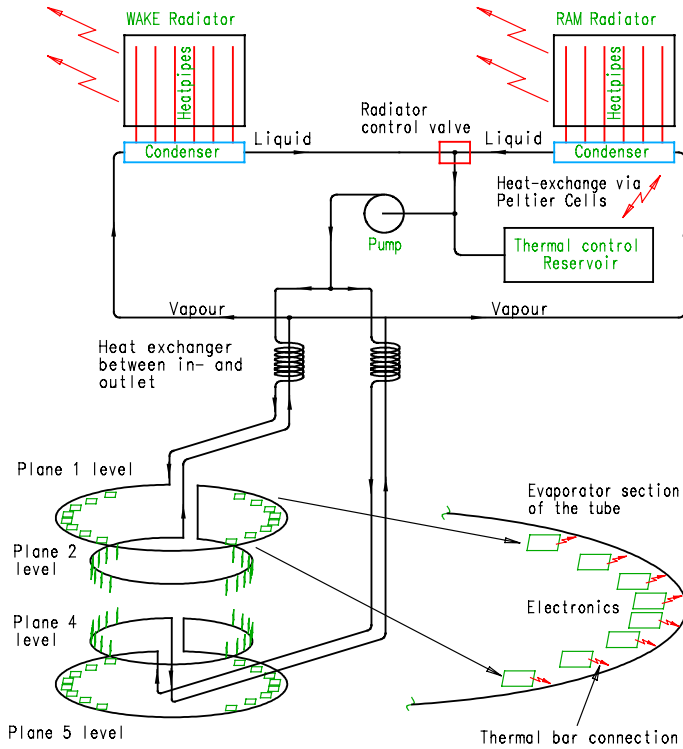

Fig. 2: Hybrid MPL Concept for the TTCS

TTCS CONCEPT

The proposed TTCS is a closed two-phase system (Figs. 3 to 5). The heat is absorbed in the evaporators and rejected to space by the radiator panels at the condensers. As the mechanical pump provides the liquid flow rate needed, it has to be located after the condensers, as it needs pure liquid to operate properly. Hence the condensers/radiators need not only to condense all vapour, but also to provide a certain amount of sub-cooling. The blue boxes on top are heat exchangers, that thermally connect inlet and outlet of the evaporator together. In this way the absorbed heat can be used to heat the entering sub-cooled liquid from the pump. So it gets close to the evaporative temperature needed in the Tracker.

The evaporators consist of two parallel tubes each having an ID of 2.6 mm and a length of 10 metres. These two tubes are serially cooling the hybrid circuits, located on the outer periphery of the Tracker. The parallel evaporator branches (Fig. 5) are routed as two rings following the widely distributed Tracker hybrids. The second branch is located similarly at the bottom of the Tracker. The evaporator tube is mounted with a copper connection bridge to the hybrid thermal support structure named thermal bars. Fig. 6 shows the thermal connection from the inner thermal bars to evaporator. Clearly visible is the bent configuration of the evaporator tube; which is needed to follow the stepped orientation of the tracker hybrid

boxes. This stepped orientation is one of the reasons that a small diameter evaporator tube was selected as the baseline, because it seemed to be the only design that was compatible with the already existing tracker hardware. There are two tubes, one is the redundant line in the case of a failure.

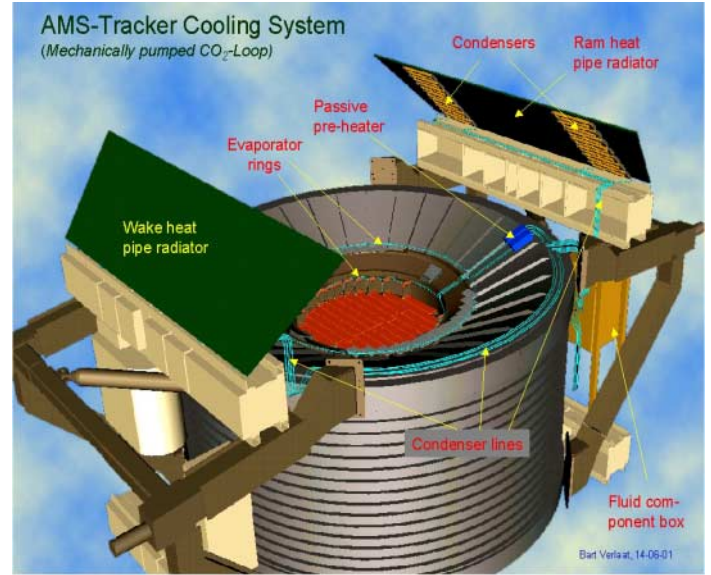

Fig. 3: Artist's Impression of Integrated TTCS

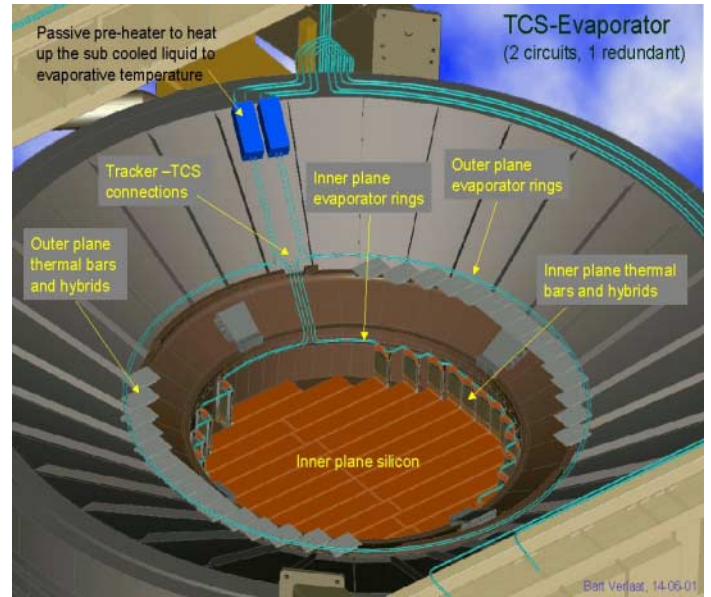

Fig. 4: Details of TTCS Evaporator

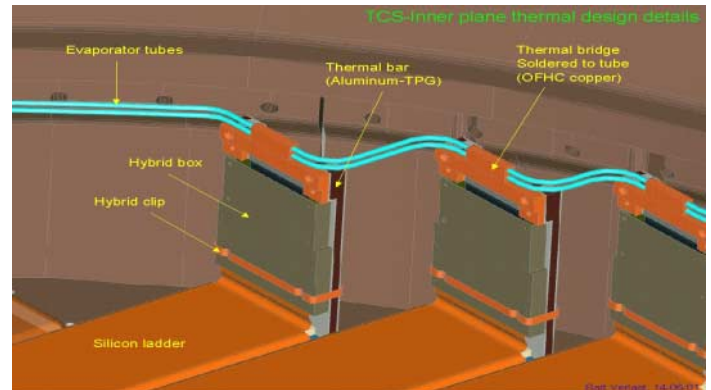

Fig. 5: TTCS Connection to Hybrids



AMS-2 radiator panels are outside the experiment, covered with high emissivity and low solar absorptivity coatings/paints. The two opposite radiator panels are thermally out of phase, meaning that there is always one radiator shaded from the sun, hence able to radiate waste heat to space. The evaporation temperature is adjusted by the system pressure. This pressure is controlled via the accumulator, a small reservoir with a mixture of vapour and liquid. A Peltier element controls the reservoir temperature, hence the system pressure by condenser flooding. The majority of the TTCS hardware is in a box outside on the support structure. Evaporators, heat exchangers and condensers are outside this box.

TEST SET-UPS AND TEST RESULTS

An open test set-up [4], built at NIKHEF in order to prove the feasibility of the TTCS evaporator concept for CO₂, consisted of an evaporator section connected to a liquid CO₂ filled bottle. The CO₂ flow was adjusted by a needle valve, the pressure in the test tube by a spring-relieve valve (at the exit). In the real TTCS all thermal bridges are individually connected to evaporator tubes. In the feasibility test heat is applied over the test section tube wall using the electric resistance of the tube as heater. Flow, pressure drop and temperatures along the tube were measured. Figures 6a,b show a picture of this test set-up and some test results, which suggest that CO₂ is an adequate refrigerant for the TTCS.

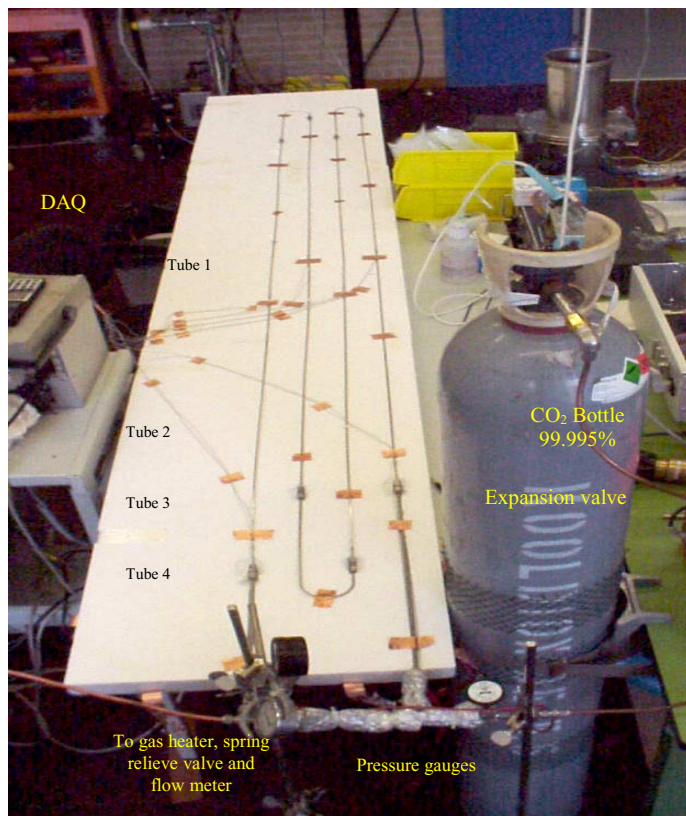

Fig. 6a: Feasibility Test Set-up

More experiments were done at NIKHEF [4] to confirm this in a closed loop set-up (Fig. 7), which more realistically simulates the TTCS. The goals of the experiments were:

- To measure the pressure drop characteristics and heat transfer coefficients at different flow rates, heat input and evaporation temperatures, using a 10 m long, 2.5 mm ID test evaporator, with helical sections between the long sections to simulate the multiple bends in the Tracker.
- To compare test outcomes to theoretical predictions and (NIKHEF/SINTEF) CO₂ test set-up experimental data.
- To prove the merits inserting a heat exchanger (as pre-heater) between evaporator in- and outlet.
- To produce recommendations for the further TTCS development, on pumping rates and evaporators.

Many experiments were executed [10], the results given here pertain only to the 10 m long, 2.5 mm ID evaporator performance, i.e.:

- Figure 8 showing the pressure and temperature drops, as a function of the mass flow, at 273 K.
- Figure 9 showing the heat transfer coefficients and observed flow patterns versus vapour quality and heat flux, at 278 K and nominal flow 2.7 g/s.

Preliminary test results confirm the profit of the presence of a heat exchanger as pre-heater between the in- and outlet of the evaporator. It was observed that up to say 90% of the heat collected in the evaporator could be reused for pre-heating the sub-cooled liquid coming from cold radiators. This amount of heat replaces part of the power to be added to the electric pre-heater that has to condition the liquid such that the fluid entering the evaporator is a pure liquid, close to saturation temperature as desired. It is obvious that the above yields a substantial power saving. Apart from this power saving impact, the presence of the heat exchanger has also a stabilising effect on the temperature excursions of the evaporator during orbital radiator temperature variations.

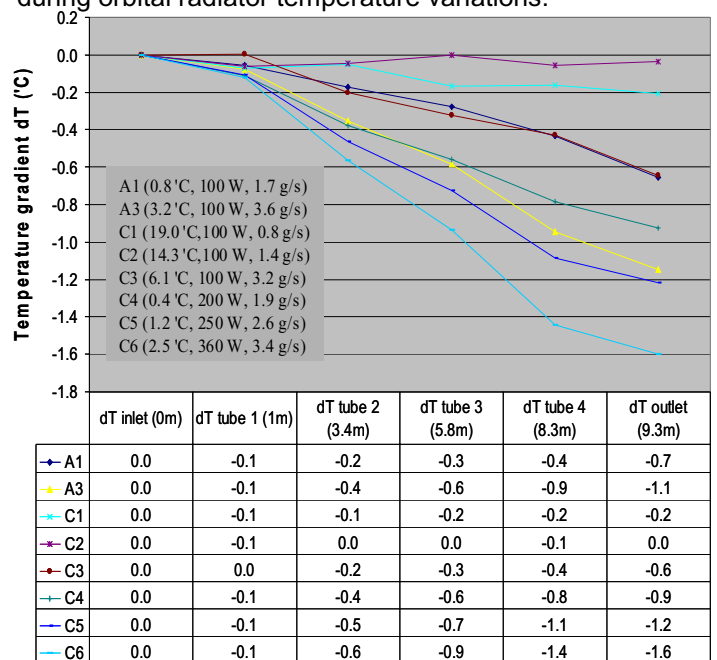

Fig. 6b: Feasibility Test Results

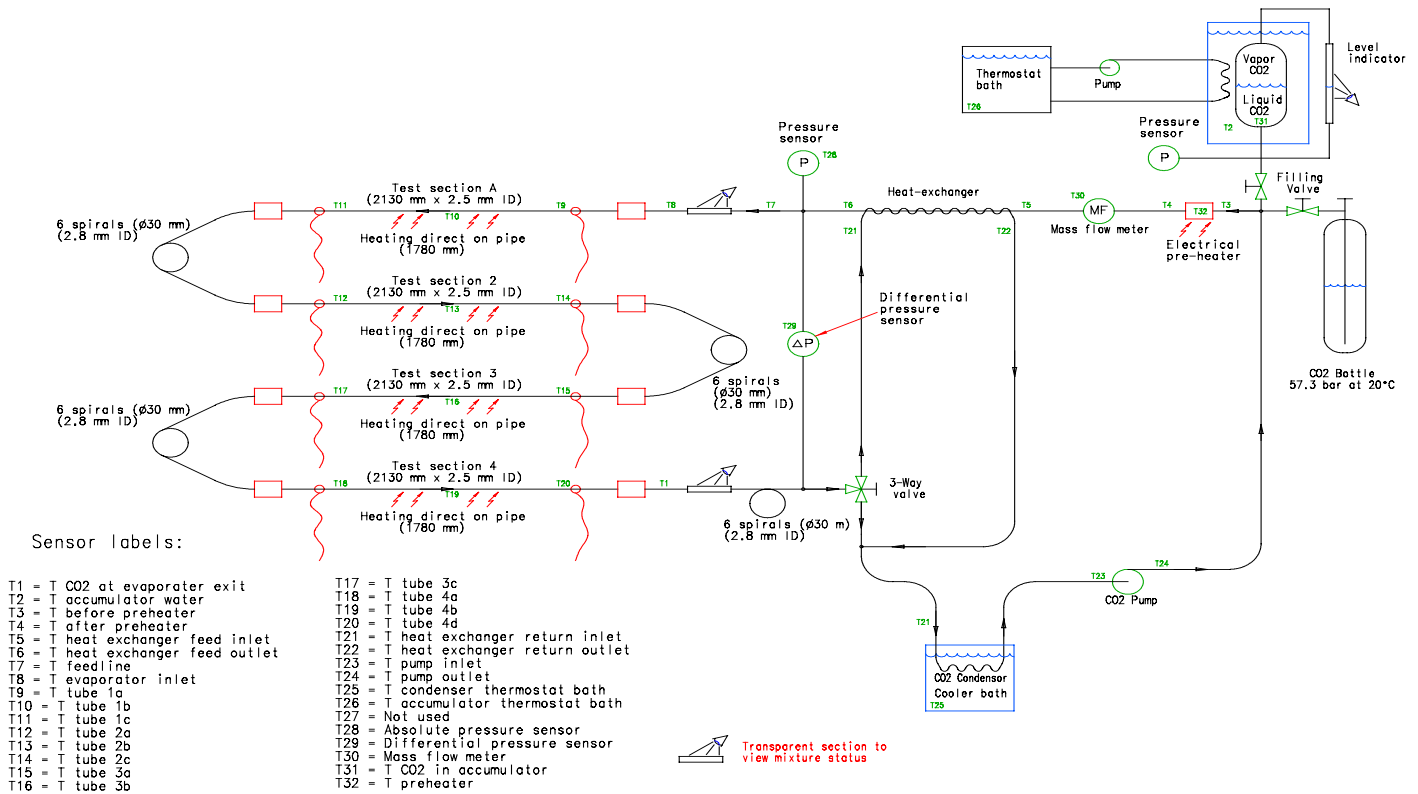

Fig. 7: Schematic of TTCS Test Loop at NIKHEF

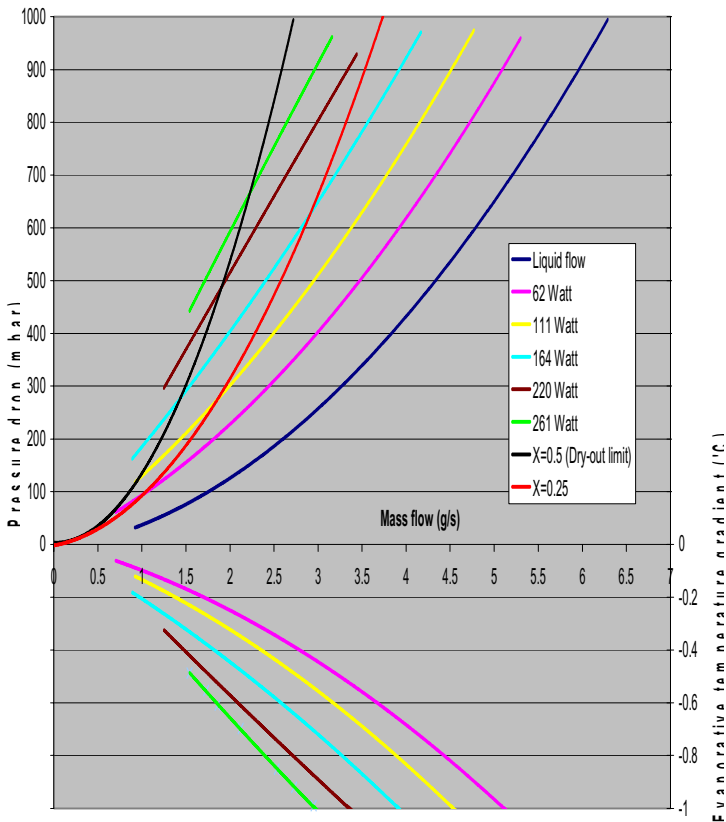

Fig. 8: Power Dependence of Pressure & Temperature Drops at 273 K

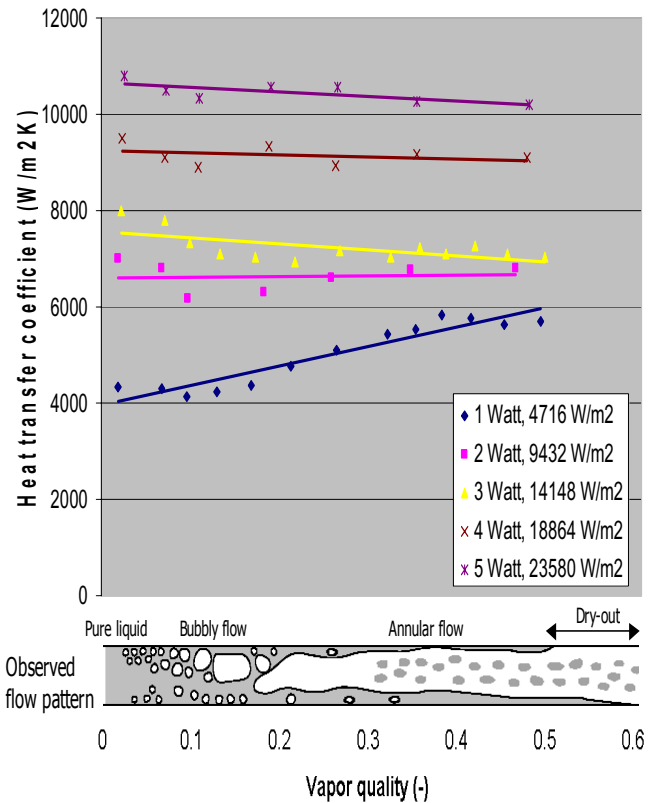

Fig. 9: HTC and Power (Density) Versus Observed Flow Patterns & Vapour Quality, at 2.7 g/s & 278 K



FULL SCALE TEST RIG

Next step in the development was the creation of a full-scale test set-up at NLR to more realistically simulate the TTCS. A preliminary rig was designed and built. Based on experimental results obtained with this rig, the full-scale test set-up was designed and manufactured. Figure 10 shows the schematic, and a photograph of the current set-up in the NLR climate chamber. Details are shown in figure 11a, evaporators, and 11b, a specimen and element of the TTCS condensers, interfacing the Ram & Wake heat pipe radiators (Fig. 3).

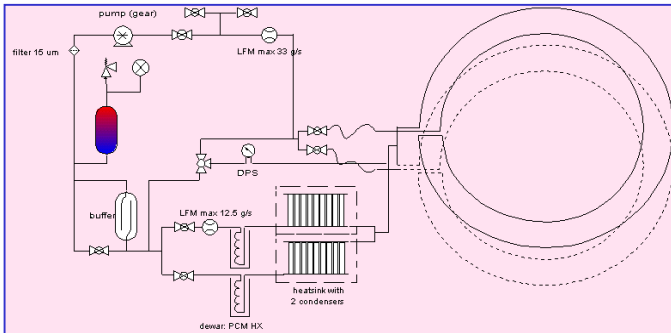

Fig.10: Schematic/Photograph of Test Rig at NLR

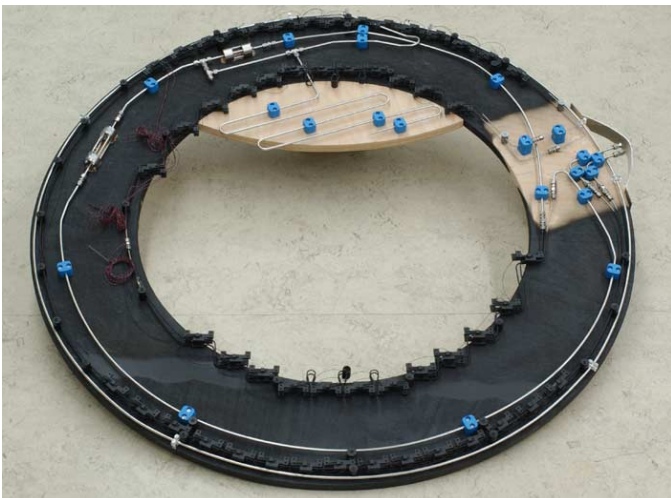

Fig. 11a: TTCS Evaporators

The first experiments with this full-size test set-up yielded very encouraging results: The pressure drops across the system turned out to be even smaller than predicted. Consequently a very good isothermality is envisaged.

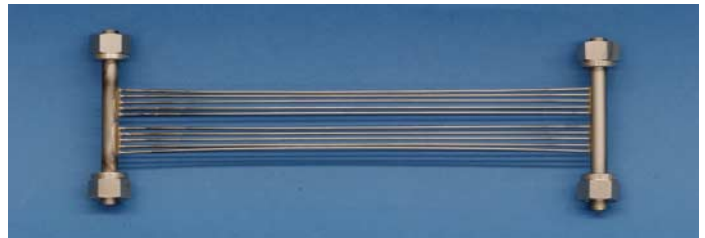

Fig. 11b: TTCS Condenser & Condenser Element

THERMAL MODELLING

Calculations with a very detailed transient TTCS model have been done for eight possible orbital (environmental loading) cases. The outcomes indicate that:

- The TTCS will operate without problems at the nominal loop set-point temperature 273 K, for the nominal case and most other thermal loading cases.
- The set-point temperature of the loop has to be increased by up to say 10 K in some hot orbital cases.
- The incorporation of the heat exchanger between evaporator in- and outlet considerably reduces the pre-heater power needed.

Currently the model is being refined and more accurate environmental loading conditions are expected to be provided by the "AMS Overall Thermal" main contractor. Using these new boundary conditions, new calculation runs will be carried out, but only after integrating useful data obtained from the full-size test rig experiments [11].

IN-ORBIT EXPERIMENTS & CONCLUSION

Apart from the challenge to develop a novel two-phase thermal control system for such an advanced experiment as AMS-2, NLR interest also pertains to acquiring in-orbit experience with real two-phase thermal control systems. NLR joined the AMS Collaboration, as it was guaranteed that AMS-2 dormant (non-operation) periods could be used by NLR to execute dedicated experiments to study in-orbit two-phase heat transport system technology issues. Therefore the TTCS will be equipped with some extra heaters, sensors, and meters.



The baseline philosophy will be that:

- There is minimum risk for Tracker and AMS-2.
- Any period AMS is not active can be used for thermal experiments
- There is at least one week of thermal experiments during the first six months
- Minimum power and mass will be added.
- The TTCS loop will, in principle, not be intruded.

Figure 12 depicts how such a fully redundant, for extra NLR experimenting equipped, TTCS can look like. However, it can already be said now that AMS-2 overall mass reduction certainly will lead to a less complicated system by partly reducing the redundancy level required and by the deleting of some components.

As said before the mechanical pumps are critical issues in the TTCS, because of:

- The almost complete lack of in-orbit experience with mechanical pumps, certainly not for long duration missions as the AMS-2 mission.
- The working fluid CO₂, which has to operate at set-point temperatures, which can be relatively close to critical point.

Because of the above, the baseline TTCS philosophy is to include two or even three pumps per loop. These currently developed pumps are upgraded versions of the Mars Rover pump, being adapted for CO₂-operation.

In conclusion it can be said that, though there is still a lot of work to be done, the Tracker Thermal Control System is on the proper track.

NOMENCLATURE

AIP	American Institute of Physics
AMS	Alpha Magnetic Spectrometer
APS	Absolute Pressure Sensor
CPL	Capillary Pumped Loop
DAC	Data Acquisition System
DPS	Differential Pressure Sensor
DP	Pressure Difference (Pa or mBar)
FSL	Fluid Science Laboratory
HTC	Heat Transfer Coefficient (W/m ² .K)
INFN	Italian Institute for Nuclear Physics
ISAS	Inst. of Space & Astronautical Science
ISS	International Space Station
LFM	Liquid Flow Meter

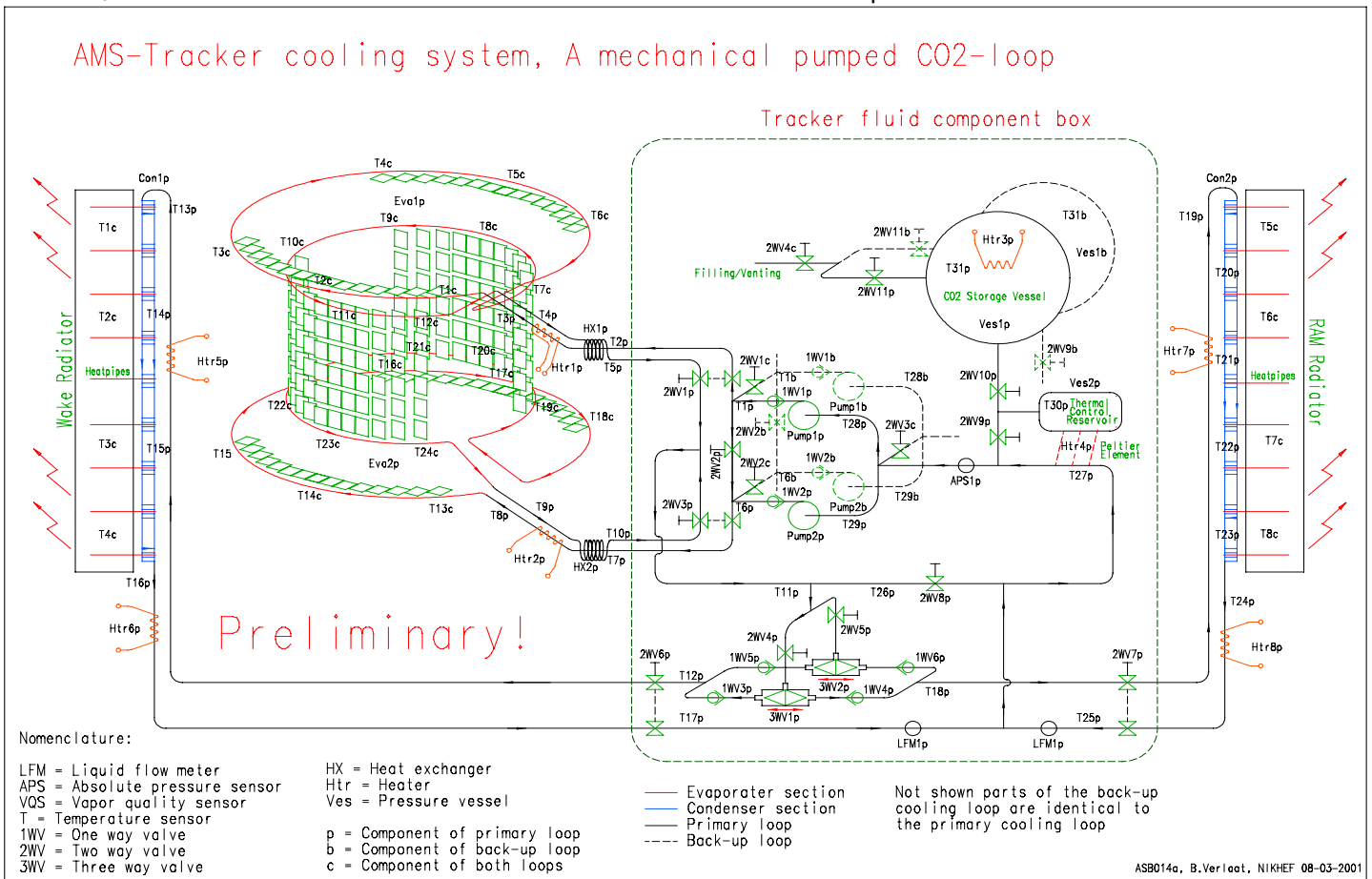

Fig. 12: Preliminary Fully Redundant TTCS, Equipped with Extra Experiment Components



LHP	Loop Heat Pipe
MPL	Mechanically Pumped Loop
NIKHEF	Duh Inst. for Nuclear & Particle Physics
NLR	Dutch National Aerospace Laboratory
SPL	Single-Phase Loop
SINTEF	Norwegian Foundation for Scientific and Industrial Research
STS	Space Transportation System (Shuttle)
TC	Thermal control
TM	Thermal Model(ling)
TPG	Thermal Pyrolytic Graphite
TPHTS	Two-Phase Heat Transport System
TTCS	Tracker Thermal Control System
VQS	Vapour Quality (Mass Fraction) Sensor

REFERENCES

1. Viertel, G.M., Capell, M., "The Alpha Magnetic Spectrometer", Nuclear Instruments & Methods in Physics Research, A419, 1998, 295-299.
2. Delil, A.A.M., "Research Issues on Two-Phase Loops for Space Applications", NLR-TP-2000-703, Proc. ISAS Symposium on Space Flight Mechanics, Sagamihara, Japan, 2000.
3. Delil, A.A.M., Woering, A.A., Verlaat, B., Boer Rookhuizen, H., Perrin, E., Pohl, M., Battiston, R., "Feasibility Demonstration of Mechanically Pumped Two-Phase CO₂ Cooling Loop for the AMS-2 Tracker Experiment", NLT-TP-2001-376, Conf. on Thermophysics in Microgravity, AIP Proc. Space Technology & Applications Int. Forum, Albuquerque, USA, 2002.
4. Woering, A.A., Pauw, A., Delil, A.A.M., "AMS Tracker Thermal Control System", NLR-CR-2001-393, 2001.
5. Boer Rookhuizen H. et al, "The CO₂ Cooling System for the LHCb Vertex Detector", NIKHEF LHCb Note/VELO, 2001.
6. Carey, V. P., "Liquid-Vapor Phase-Change Phenomena", Hemisphere Publishing Company, Washington, 1992.
7. Kandlikar, S.G., "A General Correlation for Saturated Two-Phase Flow Boiling Heat Transfer inside Horizontal and Vertical Tubes", J. Heat Transfer, 112, 1989, 219-228.
8. Pettersen, J., Rieberer, R., Munkejord, S.T., "Heat Transfer and Pressure Drop for Flow of Supercritical and Subcritical CO₂ in Microchannel Tubes", Norwegian University of Science and Technology/SINTEF Energy Research, TR A5127, 2000.
9. Delil, A.A.M., "Tutorial on Single-Component and Two-Component Two-Phase Flow and Heat Transfer: Commonality and Difference", NLR-TP-2001-417, Conf. on Thermophysics in Microgravity, AIP Proc. Space Technology & Applications Int. Forum, Albuquerque, USA, 2002.
10. Verlaat, B., Krijger, E., "Performance Testing of the AMS TTCS CO₂ Evaporator", NIKHEF ASR-T- 001/MT 01-02, 2001.
11. Woering, A.A., Pauw, A., Vries, A.W.G. de, Delil, A.A.M., Verlaat, B., "Thermal modelling Issues Concerning the Mechanically Pumped Two-Phase CO₂ Cooling Loop for the AMS-2 Tracker", NLR-TP-2002-272, SAE-2002-01-2466, Proc. 32nd Int. Conf. on Environmental systems, San Antonio, USA, 2002.

CONTACT

- A.A.M. Delil, National Aerospace Laboratory NLR, P.O. Box 153, 8300AD Emmeloord, Netherlands, Tel. +31 527248229, Fax +31 527248210, adelil@nlr.nl
- A.A. Woering, woering@nlr.nl