

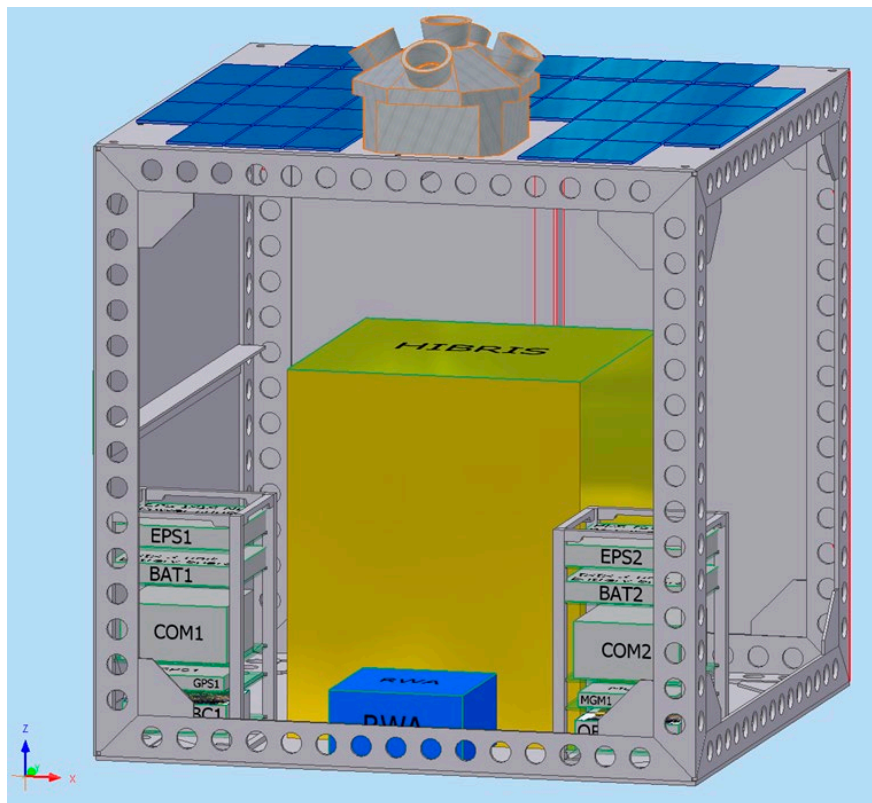

## Executive summary

# Design of a Small Satellite for a HyperSpectral Instrument

**Report no.**

NLR-TP-2012-292

**Author(s)**
B.A. Oving  
A.J.P. van Kleef
**Report classification**

UNCLASSIFIED

**Date**

October 2012

**Knowledge area(s)**

Ruimtevaartinfrastructuur

**Descriptor(s)**
smallsat  
hyperspectral instrument  
sensor network  
cubesat
**Problem area**

This paper describes the design of a generic small satellite with a hyperspectral imager as part of a sensor network for Earth observation. The satellite is targeted for a low Earth orbit of 500 km and its design is based on CubeSat technology, with a launch mass of around 20 kg, a cubical size of 43 cm, and an operational lifetime of 2 to 3 years.

**Results and conclusions**

This satellite is designed for a future low cost constellation (sensor network) with high temporal resolution. Hence, a second communication unit is taken into account for inter-satellite links.

The target payload is a redesign of the Highly Integrated Broadband Imaging Spectrometer (HIBRIS) from cosine BV. The instrument

This report is based on a presentation held at the 4S Symposium, Portorož, June 7, 2012.

contains a Near Infrared Hyper-spectral Imager (NSI) as well as a Thermal Infrared (TIR) detector. Based on the properties of this instrument, a reference satellite design was defined.

The satellite is 3-axes stabilised using magnetometers and magnetorquers for de-tumble and back-up, and using star tracker and reaction wheels for fine pointing.

Simulations over short and long periods (up to one year) were executed with the NLR spacecraft simulator to retrieve the power

generation and dissipation, to verify attitude control performance, and to analyse the thermal characteristics.

The on-board computer design is based on a COTS Cortex-A9 platform, for which a fault-tolerant software application framework has been designed. A hardware platform has been set up to act as a closed-loop test bench to verify the on-board software, in specific the attitude control algorithms.



NLR-TP-2012-292

## Design of a Small Satellite for a HyperSpectral Instrument

B.A. Oving and A.J.P. van Kleef

This report is based on a presentation held at the 4S Symposium, Portorož, June 7, 2012.

The contents of this report may be cited on condition that full credit is given to NLR and the authors.  
This publication has been refereed by the Advisory Committee AEROSPACE SYSTEMS.

Customer                      National Aerospace Laboratory NLR  
Contract number            - - -  
Owner                          NLR  
Division NLR                 Aerospace Systems  
Distribution                  Unlimited  
Classification of title      Unclassified  
October 2012

Approved by:

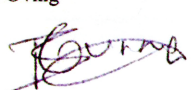
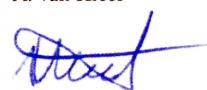
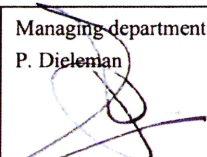
Author B. Oving 	Reviewer A. van Kleef 	Managing department P. Dieleman 
Date: 2/9/2012	Date: 2/9-2012	Date: 3/9-2012





## Summary

This paper describes the design of a generic small satellite with a hyperspectral imager as part of a sensor network for Earth observation. The satellite is targeted for a low Earth orbit of 500 km and its design is based on CubeSat technology, with a launch mass of around 20 kg, a cubical size of 43 cm, and an operational lifetime of 2 to 3 years.

This satellite is designed for a future low cost constellation (sensor network) with high temporal resolution. Hence, a second communication unit is taken into account for inter-satellite links.

The target payload is a redesign of the Highly Integrated Broadband Imaging Spectrometer (HIBRIS) from cosine BV. The instrument contains a Near Infrared Hyper-spectral Imager (NSI) as well as a Thermal Infrared (TIR) detector. Based on the properties of this instrument, a reference satellite design was defined.

The satellite is 3-axes stabilised using magnetometers and magnetorquers for de-tumble and back-up, and using star tracker and reaction wheels for fine pointing.

Simulations over short and long periods (up to one year) were executed with the NLR spacecraft simulator to retrieve the power generation and dissipation, to verify attitude control performance, and to analyse the thermal characteristics.

The on-board computer design is based on a COTS Cortex-A9 platform, for which a fault-tolerant software application framework has been designed. A hardware platform has been set up to act as a closed-loop test bench to verify the on-board software, in specific the attitude control algorithms.



## **Contents**

<b>Abbreviations</b>	<b>5</b>
<b>1 Space-based sensor networks</b>	<b>7</b>
<b>2 Starting points</b>	<b>9</b>
<b>3 Payload selection</b>	<b>10</b>
<b>4 Satellite design</b>	<b>11</b>
<b>5 Mission simulator</b>	<b>14</b>
<b>6 Power generation and dissipation</b>	<b>16</b>
<b>7 Thermal analysis</b>	<b>19</b>
<b>8 Attitude control</b>	<b>20</b>
8.1 De-tumble mode	20
8.2 Nominal Earth pointing mode	20
<b>9 On-board software</b>	<b>22</b>
<b>10 Test bench</b>	<b>24</b>



## Abbreviations

AIS	Automatic Identification System
FOV	Field-Of-View
GGNC	Guidance, Navigation, Control
GPS	Global Positioning System
HIBRIS	Highly Integrated Broadband Imaging Spectrometer
IR	Infra-Red (spectrum)
LEO	Low Earth Orbit
NSI	Near Infrared Hyper-spectral Imager
RAAN	Right Ascension of the Ascending Node
SEL	Single Event Latch-up
SOI	Silicon-On-Insulator
SPA	Solar Panel Array
SRF	Spacecraft Reference Frame
STK	Satellite Toolkit
TI	Thermal Imager
TMR	Triple Modular Redundancy
TM/TC	Telemetry/Telecommands
TRF	Target Reference Frame
UAV	Unmanned Aerial Vehicle
VIS	Visual (spectrum)



This page is intentionally left blank.



## 1 SPACE-BASED SENSOR NETWORKS

Since with current technology one is able to build small satellites at reduced costs, what can small satellites bring to society?

Limited in size, mass, and power consumption, they also are limited with respect to the type of instruments that can be flown. However, the reduced cost per satellite allows building many small satellites for the price of a single large one. Groups of small satellites can be used as a swarm to form a synthetic aperture with increased resolution or, as will be discussed here, in a constellation to decrease revisit times significantly.

A small revisit time is beneficial for monitoring and detection applications, such as maritime monitoring (ships, coastal zones, water quality), fire monitoring and detection, disaster monitoring and detection. To achieve very small revisit times in the order of an hour or less combined with a sufficient level of sensor resolution, a large network of satellites is necessary, which may lead to the concept of a satellite sensor network or a satellite sensor web.

Here, a single satellite is basically a sensor node communicating with a larger network of sensor nodes. Inter-satellite links allow for <sup>a)</sup> global data communication and <sup>b)</sup> for a reduced set of ground stations for monitoring & control and instant data retrieval (“satellite-as-a-service”). Several types of sensor nodes can be part of the network, e.g. satellites with different instruments (AIS, IR, VIS). But the network may also contain other types of sensor platforms, such as airplanes or unmanned aerial vehicles (UAV).

To show the potential of a space-based sensor network, an example constellation of 225 low cost satellites was examined using the Satellite Toolkit (STK). The constellation consists of 15 polar orbital planes, each plane having 15 satellites with inter-satellite links and a sensor with a 14° field-of-view (FOV). With such a network, global revisit times of less than 30 minutes can be achieved, while Europe is revisited about every 15 minutes.

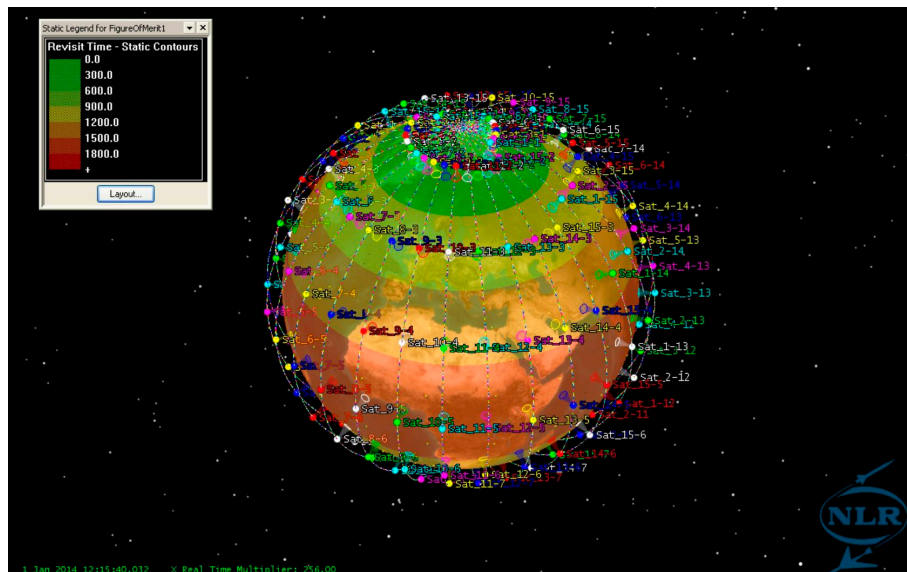

Figure 1 STK example of a 225-node sensor network

Typically in space missions, the satellite stores its data on-board and sends it to ground once it passes a ground station. However, for a sensor network, the amount of data that is gathered can be enormous, so that a different approach should be applied, in which the satellite transmits its most recent data continuously to ground. This does require users to procure their own ground station, but has the advantage that the user immediately has the most recent information. Application-specific ground systems can process the data and transmit it wireless to the user, such as a farmer or a fire fighting crew.

This paper presents the design of a generic satellite that can be used as a versatile node in a sensor network.

## 2 STARTING POINTS

Given the intention to design a generic satellite for a space-based sensor network, what are the starting points for such a satellite?

As the satellite needs to be produced in relatively large quantities, the design must use guidelines for low cost series production. These include:

- ensure that each satellite platform is the same, while it must be able to accommodate several types of instruments; this will lead to an over-sized, non-optimal platform;
- use commercial components where possible; this will lead to lower life expectancy;
- use the same components where possible, e.g. use the same communications technology for ground links and for inter-satellite links;
- break-down the satellite into modules that can be assembled separately; this will simplify the final integration.

Furthermore, the amount of satellites calls for autonomous operation to reduce the monitoring and control effort.

As the satellites will be put into various orbits, the design must be “orbit-independent”, i.e. take the following into account in order to operate in various orbits throughout the years:

- generate enough power and store power to allow operation during eclipses;
- ensure thermal stability.

It is difficult to specify the lifetime of a single satellite. Assuming that the constellation as a whole will have a longer lifetime than a satellite, replenishment is necessary. Then, the lifetime becomes a trade-off between the cost due to the complexity (redundancy) of building the satellite and the cost of launching new satellites. The starting point chosen is to keep the satellite simple with some redundancy where it does not cost much in terms of power, mass, and money. This assumes that affordable dedicated launch options will become available in time.

Regarding the payload, it shall be possible to use several types of instruments, given that the satellite will be limited in power and in data rate. For continuous operation, a limit of about 15 W for the instrument is set in order to keep the satellite dimensions smaller than half a meter cubed. Currently available CubeSat S-band technology yields a maximum data rate of about 1 Mbit/s, which means that the instrument’s data rate is limited to 30 Mbit/s allowing a data refresh every 30 seconds.

### 3 PAYLOAD SELECTION

Now that the starting points are known, which payload should be selected to achieve a generic node of a space-based sensor network?

Passive instruments such as AIS receivers and cameras may not stress the payload limits, whereas active instruments such as radars would exceed the limits. Thus, an actively-cooled hyperspectral instrument was chosen as the baseline instrument for a generic satellite sensor. This payload is based on the Highly Integrated Broadband Imaging Spectrometer (HIBRIS) design of cosine Measurement Systems. A laboratory version of this instrument is currently being built by a Dutch consortium led by cosine.

The instrument contains an actively-cooled Near Infrared Hyper-spectral Imager (NSI) with the following target characteristics:

Table 1 Near-infrared detector target characteristics

Property	Value
Spectral ranges	700 - 1400 nm, 1400 - 2800 nm, 2800 - 5200 nm
Spectral resolution	1% of central $\lambda$
Spatial resolution (at 500 km)	125 m
FOV	14.5°

and a Thermal Imager (TI) with:

Table 2 Thermal infrared detector target characteristics

Property	Value
Spectral range	10 - 73 $\mu\text{m}$
Spectral resolution	7 $\mu\text{m}$
Spatial resolution (at 500 km)	360 m
FOV	6.9°

Estimated total power consumption of the instrument is on average 8.5 W with a maximum of 11 W. The NSI detector needs to be cooled to 80 K, which requires an active cooling system responsible for 7 W continuously and an initial peak of about 20 W. The size of the instrument is 22 x 26 x 21 cm with a mass of about 5 kg. A pointing stability of ca 30 arcsec/s is necessary to avoid smear. The effective data rate is estimated at 25 Mbit/s.



## 4 SATELLITE DESIGN

What does this mean for the satellite?

Following specifications can be derived from the starting points:

- a star tracker and reaction wheels are necessary to achieve the pointing requirements set out by the instrument;
- a magnetometer is necessary for situations where the star tracker does not work, e.g. during de-tumbling;
- magnetorquers are necessary for de-tumbling and for off-loading the reaction wheels;
- a GPS receiver is needed for autonomous orbit determination;
- a high-performance on-board computer is required for autonomous operation and to compress the data from the instrument, so that the data refresh rate to ground can be increased;
- body-mounted solar panels are needed to generate power in various orbits, while pointing both to Earth and to the next satellite in the orbital plane (for inter-satellite communication);
- the structure shall be sized both to enclose the instrument and the other components, and to generate enough power through the body-mounted solar panels;
- two S-band communications systems are required: one for ground link and one for inter-satellite link;
- a system of heat pipes is necessary to achieve thermal stability.

Products are chosen from the CubeSat shop, when available. Some components are not yet available (star tracker) or must be developed specifically for this satellite (structure, solar panels). Others can be found via Internet (GPS receiver, Cortex-A9 computer board). The design uses two on-board computers (for redundancy) and two power supplies (to increase reliability upon on-board failures).

The size of the satellite is determined by the number of solar cells needed. For continuous operation, the components use a total of 30 W. For a random polar orbit, this means that some 40 solar cells should be mounted on a solar panel, leading to a cube-formed satellite with dimensions 43 x 43 x 43 cm. The satellite has five identical solar panel arrays (SPA) for all sides of the cube except the base-plate (facing Earth). With this set-up, the power supply must be rated up to 80 W to allow batteries to be charged for operation during eclipse.

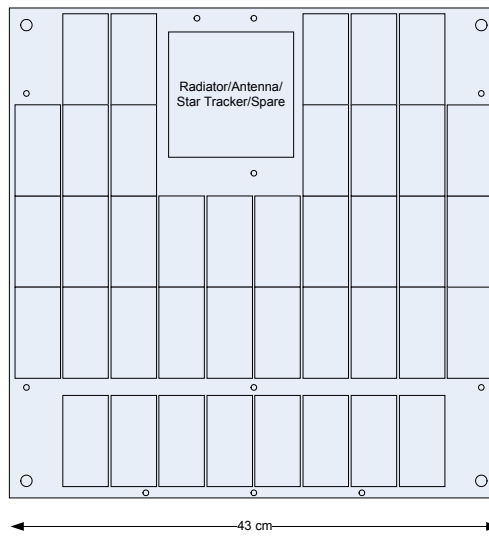

Figure 2 Solar panel layout

As all components can fit into CubeSat structures, it is possible to create subassemblies, in this case two 1.5U CubeSat boxes:

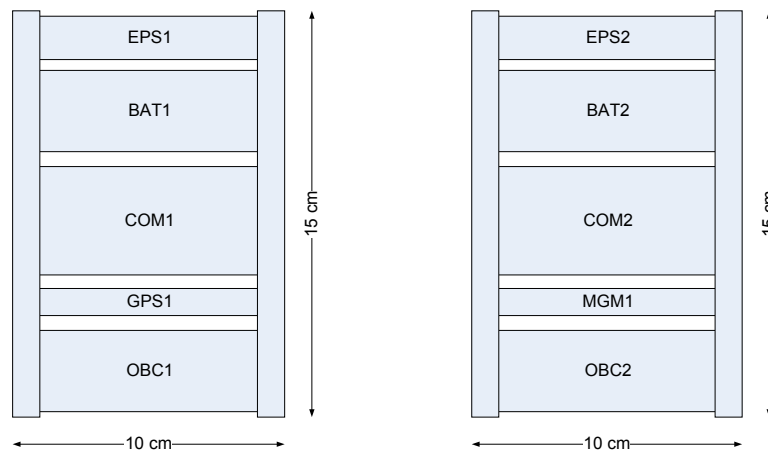

Figure 3 Box 1 (left) and Box 2 (right)

Each box weighs about 850 gr. Box 1 however consumes slightly more power, due to the GPS receiver. The mass of the total satellite is about 20 kg.

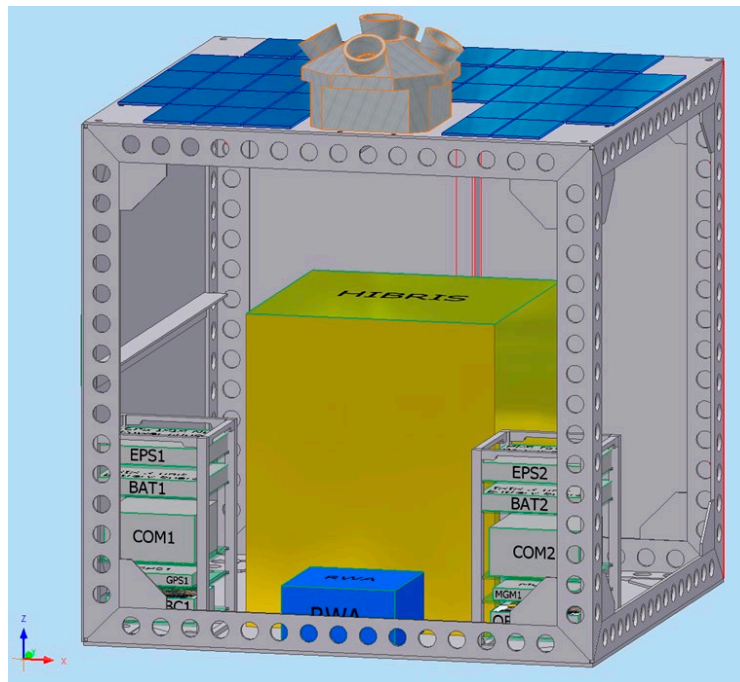

Figure 4 Satellite overview

Figure 4 shows the satellite with the two subassembly boxes, the instrument (yellow), the reaction wheel assembly (blue) and the star tracker (on top). Not shown in this picture are the heat pipes that are mounted to the solar panels in the horizontal plane. There is ample room to ease the integration.

## 5 MISSION SIMULATOR

A mission simulator was developed in Matlab/Simulink using models for the satellite components and using the environment models of the GGNC library developed by Dutch Space.

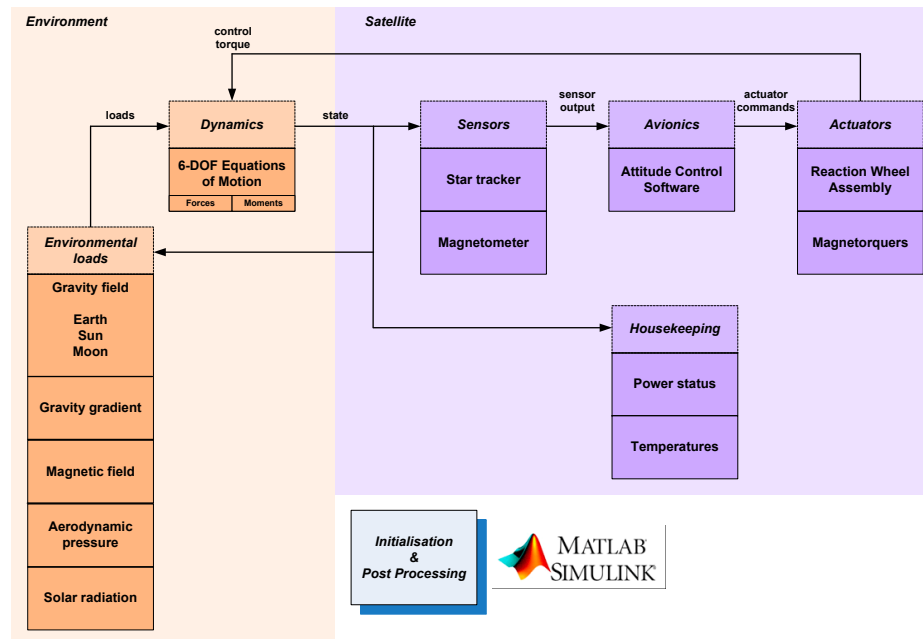

Figure 5 Overview of mission simulator

The mission simulator is used to analyse the main aspects of the mission performance such as the power balance, on-board temperatures, and attitude control based on the foreseen hardware. Satellite Tool Kit is used for analysing the budget links for the down/uplink and inter-satellite communication functions.

For the power and thermal analysis, three simulations have been performed to analyse the effect of orbit orientation with respect to the Sun on the spacecraft's power budget and temperature ranges. Both power and temperature aspects are simulated in one single model due to their mutual dependencies.

For each simulation, the (polar) orbit is chosen such that angle between the orbital plane and the Sun-vector matches  $0^\circ$ ,  $45^\circ$  and  $90^\circ$  (right ascension of the ascending node, RAAN). For an angle of  $0^\circ$  and  $45^\circ$ , the spacecraft experiences eclipses ("cold-case") whereas an angle of  $90^\circ$  represents a situation in which the spacecraft receives continuous sunlight at one side ("hot-





case”). For an angle of  $45^\circ$ , the spacecraft’s solar panels generate the maximum total power levels since a maximum of 4 panels are able to receive sunlight.

For each simulation, the spacecraft’s attitude profile remains Earth-pointing. Each simulation starts on equinox of 03-21-2014 and represents about 10 orbits in order to reach equilibrium temperatures. Furthermore, for the RAAN  $0^\circ$  and  $90^\circ$  cases a simulation duration of one year is used as well to analyse seasonal effects.

## 6 POWER GENERATION AND DISSIPATION

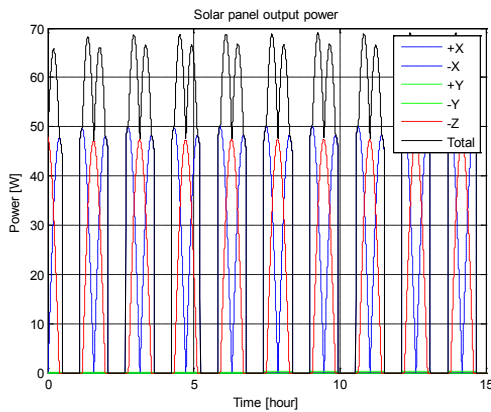

Figure 6 Power generation RAAN 0°

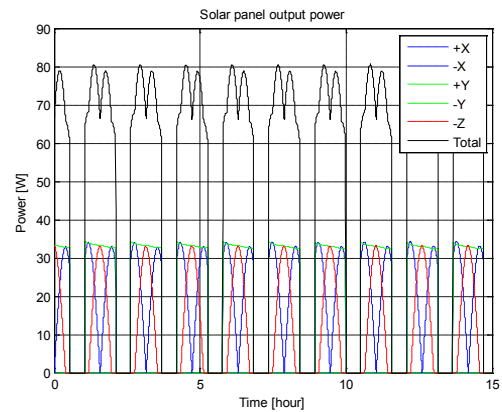

Figure 7 Power generation RAAN 45°

During the simulation run, continuous power consumption is foreseen. If the requested power is lower than the generated power by the solar panels when the batteries are fully charged, the excess power is dumped via a heater into the base-plate. During eclipse, power generation is stopped and batteries will provide the power to the units. The depth-of-discharge of the batteries is kept above 55%.

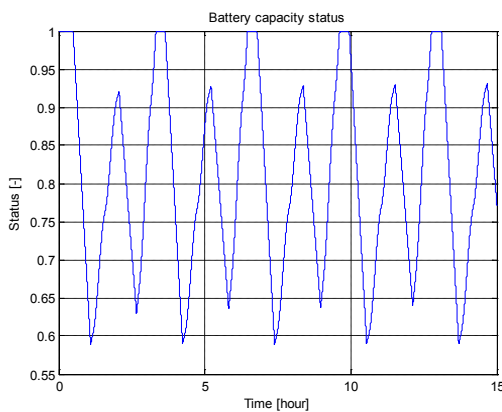

Figure 8 Battery capacity RAAN 0°

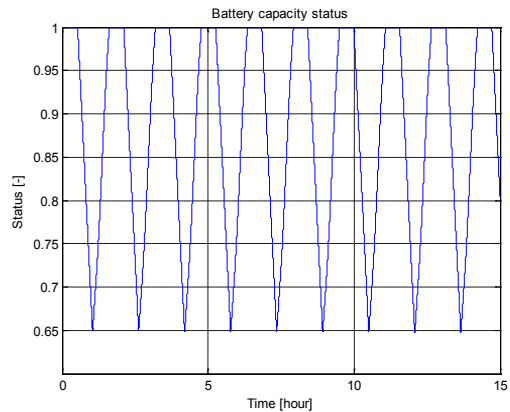

Figure 9 Battery capacity RAAN 45°

If the battery is not fully charged before the start of a new eclipse period, the inter-satellite communication link and the secondary on-board computer are powered down temporarily (duty cycle), as is shown in figure 10. Subsequently, if the battery is fully charged before entering the next eclipse, all units are switched on again and power consumption is back to normal.

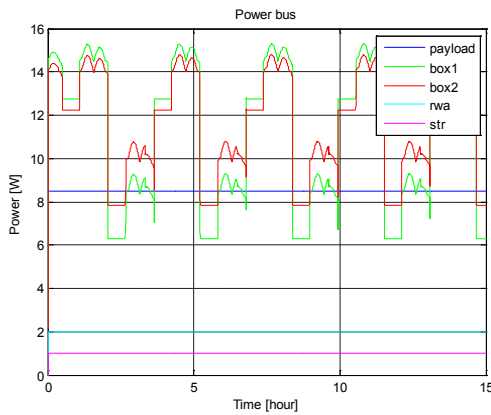

Figure 10 Power dissipation RAAN 0°

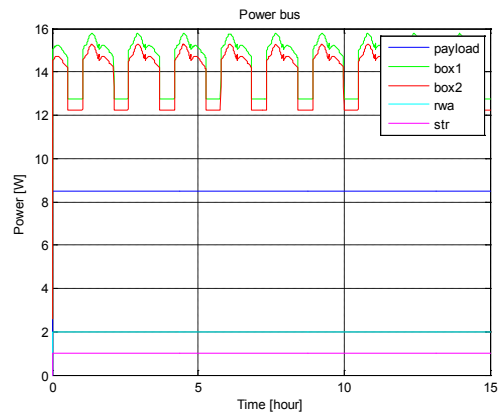

Figure 11 Power dissipation RAAN 45°

Figures 12 and 13 show the variation in power generation over a year for RAAN 0° and 90° cases.

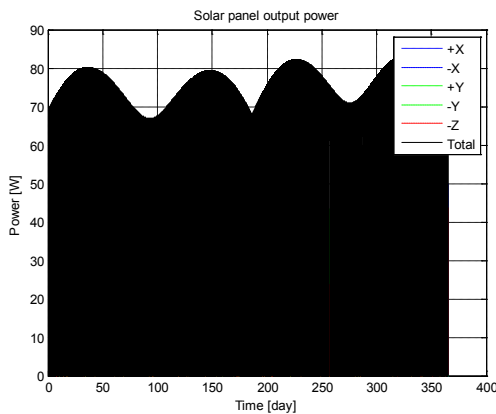

Figure 12 Power generation RAAN 0°

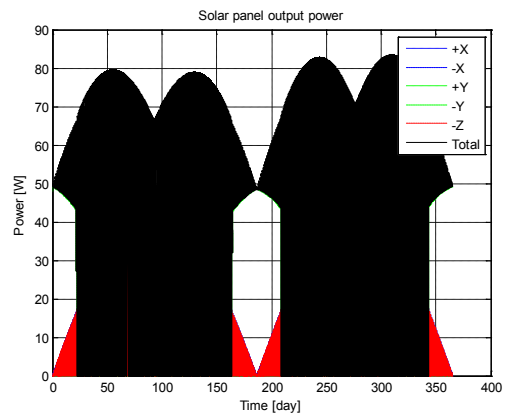

Figure 13 Power generation RAAN 90°

The RAAN 90° starts in sun-synchronous mode, in which enough power is generated for continuous operation and hence the batteries are fully charged. However, over the year, seasonal effects occur. Figures 14 and 15 show that duty cycling is only necessary during a limited number of days in a year.

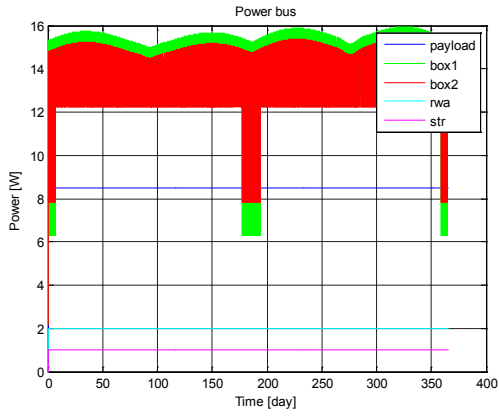

Figure 14 Power dissipation RAAN 0°

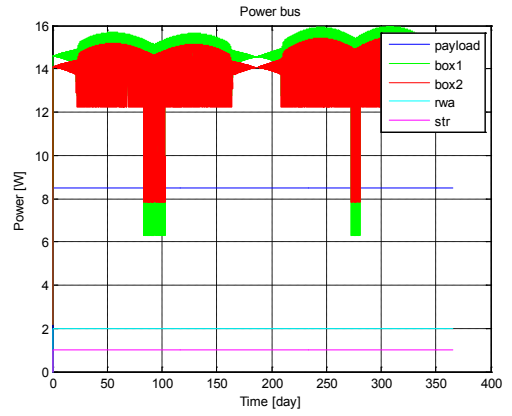

Figure 15 Power dissipation RAAN 90°

## 7 THERMAL ANALYSIS

For the thermal analysis, a total of 11 thermal nodes are defined (similar to the power nodes). The sides of the cube and the star tracker are exposed to the sun, the Earth’s albedo, and the Earth as an infrared source. The solar panels along the X- and Y-sides are thermally connected by heat pipes on water basis, where the effect of cyclic freezing is not taken into account. Any excess power is dumped into the base-plate. The internal nodes are thermally connected to the base-plate, whereas the star tracker is thermally connected to the  $-Z$  side.

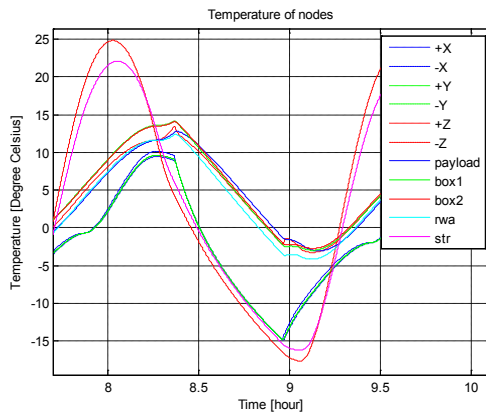

Figure 16 Temperatures RAAN 0°

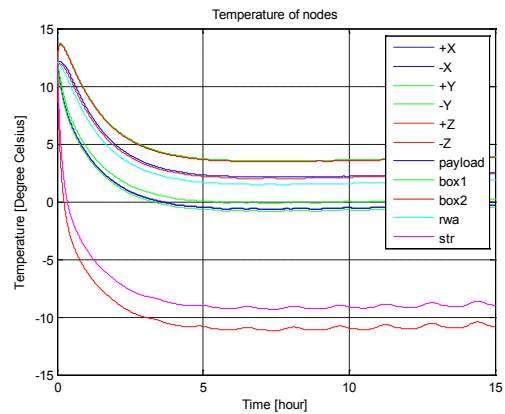

Figure 17 Temperatures RAAN 90°

The results for the worst case in a year show that the solar panels on the X-sides and Y-sides can have temperatures below 0°C. The RAAN 45° case shows similar results as the RAAN 0° case, but the temperatures are some 10°C higher. Hence, the water in the heat pipes may become frozen. Either another medium should be selected or the heat pipes will stop distributing the heat until they warm up.

Simulations for the three RAAN cases over a full year show that the  $-Z$  panel and star tracker experience the largest temperature variations: between -20°C and +30°C. The X and Y solar panels have a temperature range between -15°C and +20°C. The internal nodes follow temperature variations of the base-plate +Z between -5°C and +25°C.

## 8 ATTITUDE CONTROL

### 8.1 De-tumble mode

After separation with the launcher, the satellite is in a random state, tumbling around the Earth. To de-tumble the satellite, the attitude control system will align the Spacecraft Reference Frame (SRF) in the direction of the Earth's magnetic field, as measured on-board. This should be a safe start condition to switch to another pointing mode. For this attitude control mode, only the magnetometer and magnetorquers are used. A 1 Hz control loop is applied.

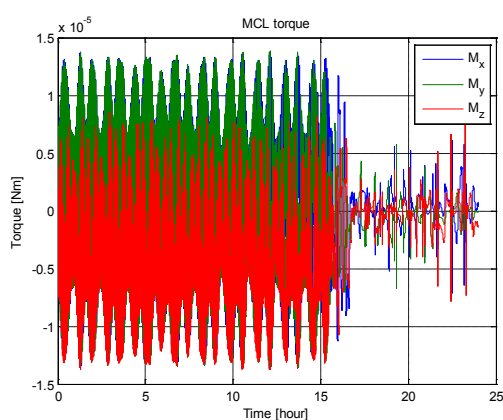

Figure 18 Control torques during de-tumble

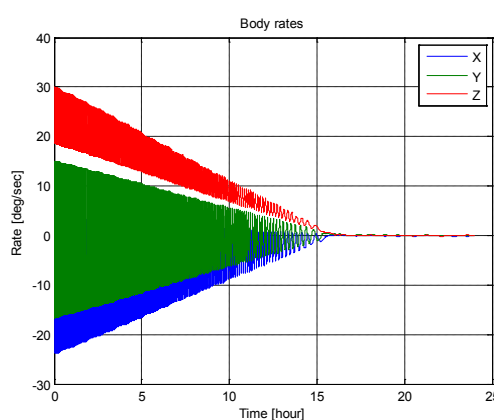

Figure 19 Body rates during de-tumble

Given the initial spin conditions, de-tumbling takes about 17 hours to reduce rotation rates to levels less than 0.2 deg/sec. After 17 hours, the control switches to nominal mode, where the star tracker and the reaction wheels kick in, leading to a rapid stabilisation.

### 8.2 Nominal Earth-pointing mode

In the Earth-pointing mode, the SRF is aligned with the Target Reference Frame (TRF):

- +Z axis is pointing towards Earth (nadir vector),
- +Y axis is opposite to the orbit's momentum vector,
- +X axis is in the direction of the velocity vector (perfectly aligned for a circular orbit).

In this mode, the star tracker and reaction wheels are used. Blinding effects are simulated as part of the measurement noise of the star tracker. For the reaction wheels, both stiction and friction are taken into account. A dual-mode control law is implemented combining a non-linear bang-bang control law (for large angle manoeuvres) with a linear feedback control law (fine-pointing) using Kalman filtering. The control loop runs at 2 Hz. The following disturbance torques are taken into account:

- magnetic;
- gravity gradient;
- aerodynamic pressure;
- solar radiation.

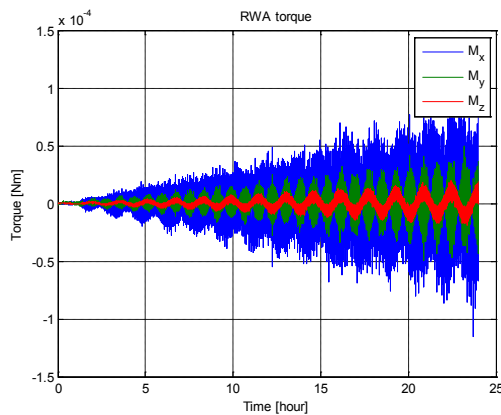

Figure 20 Reaction wheel torques

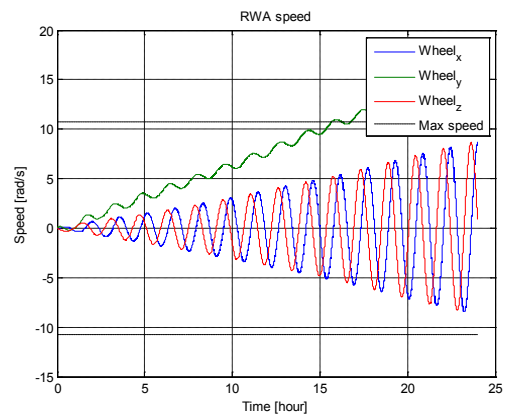

Figure 21 Reaction wheel speeds

When the reaction wheels reach their maximum speed (spinning up for compensating external disturbance torques), the built-up momentum need to be unloaded using the magnetometer and magnetorquer. Frequency for momentum unloading of reaction wheels is at least once per day.

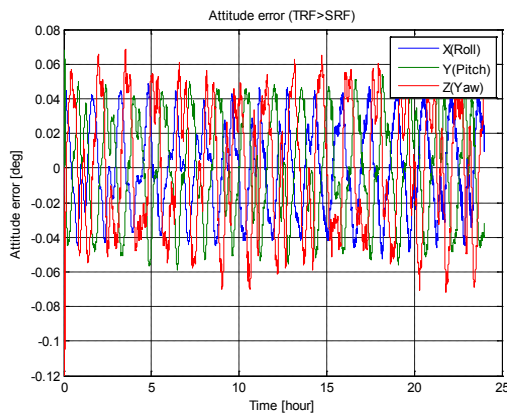

Figure 22 Attitude errors

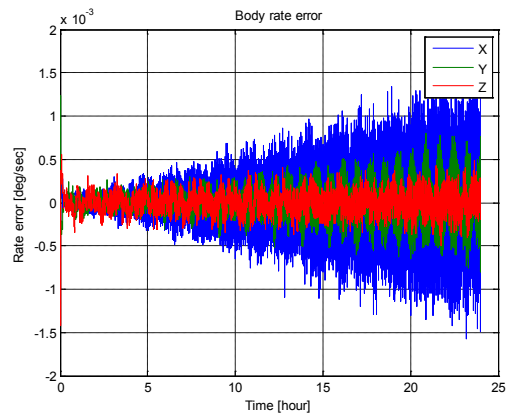

Figure 23 Rate errors

The attitude error is maintained within 0.06 deg (220 arcsec), whereas the body rate error is maintained within 0.001 deg/s (4 arcsec/s) before the reaction wheels need to be unloaded. The body rate error is well below the required 30 arcsec/s. The error rates are increasing due to the increasing torques delivered by the reaction wheels for counteracting corresponding cross coupling torques.

## 9 ON-BOARD SOFTWARE

One of the objectives is to bring smartphone technology to space. At the moment, ARM Cortex-A9 processors are the standard for mobile smartphones. The Cortex-A9 has a good floating point unit, unlike its predecessor the Cortex-A8. The performance of a 1 GHz dual-core Cortex-A9 is 20 times that of a LEON2 processor, currently used in European space missions, for integers and instructions and about 6 times for floating-point, at a power consumption of 0.5 W.

The near future will show Cortex-A15 multi-core with another 5 times improvement over Cortex-A9 at the same level of power consumption. Moreover, system-on-a-chips based on these ARM cores have plenty of features, such as a large amount of built-in random access memory and various integrated interface controllers, in a very package.

These features allow failure mitigation techniques such as Triple Modular Redundancy (TMR) for dealing with soft errors (bit flips) to be implemented in software, instead of in hardware. Note that the bulk CMOS process, with which most of these chips are produced, does not prevent potential destructive Single Event Latch-ups (SEL).

Other manufacturing processes such as HCMOS and Silicon-On-Insulator (SOI) may reduce or even remove the susceptibility to SEL. Also, total dose effects may still limit the lifetime of these chips. In other words, these chips can be used for relatively short LEO missions, but for long missions further away from Earth, traditional solutions should be used, at least for now.

The Cortex-A9 is able to run Linux as an operating system, which would also be a cost-saver regarding on-board software development. A failure-tolerant software application framework is developed under Linux, which applies various mitigation techniques:

- keep-alive mechanism to monitor other processes;
- checksum mechanism to check own code integrity;
- redundancy in data (triple data with voting and scrubbing);
- redundancy in processes (triple processes with voting).

Figure 24 presents an overview of this framework, where processes are launched that are responsible for the actual processing of the functional software, such as the attitude control software. Inter-process communication is done via shared memory (shm). All data is protected by triple modular redundancy, whenever possible. This applies to internal variables and to external variables in shared memory.



More than one instance of a process can be launched by forking, thus implementing redundancy in processes. The results of these processes are combined (via voting) by another process.

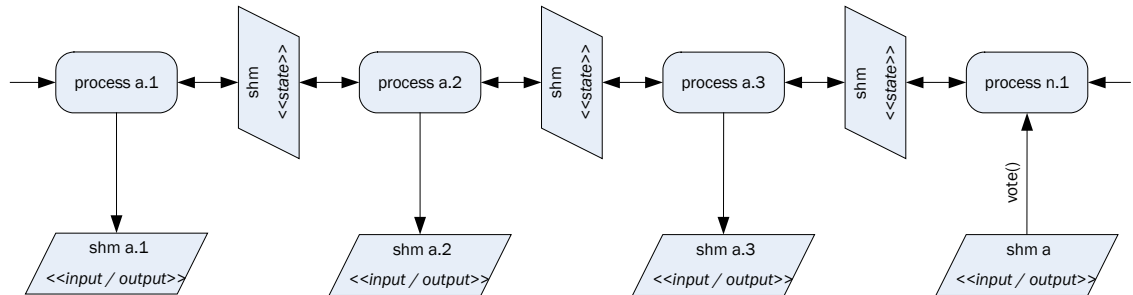

Figure 24 Failure-tolerant application framework

The processes implement a keep-alive mechanism that uses a state flag, which is set by the one process to be unset by the other. Periodically, it is checked if the state indeed has changed. The same mechanism is used to control the state of execution of processes and their children. In this way, synchronisation between the processes (specifically, the children) can be enforced.

Furthermore, each process periodically checks the integrity of its code segment. If the check fails, the keep-alive flag is not updated: the process is killed and a new process is started. The application framework is coded in C.

## 10 TEST BENCH

The low cost nature of small satellites is reflected in the verification approach by minimising testing effort, especially with hardware-in-the-loop:

- functional interface tests;
- functional closed-loop test with a hardware on-board computer, simulated environment and simulated units;
- functional integrated system test;
- thermal-vacuum test;
- vibration tests.

A test bench is developed that is able to execute the functional tests. Using Matlab's Real-Time Workshop, the complete mission simulator including environment, dynamics, and satellite models is ported to C code. This is then converted by the MOSAIC tool to a EuroSim project.

In parallel, the attitude control software is converted manually from Embedded Matlab to C++ and embedded in the on-board application framework.

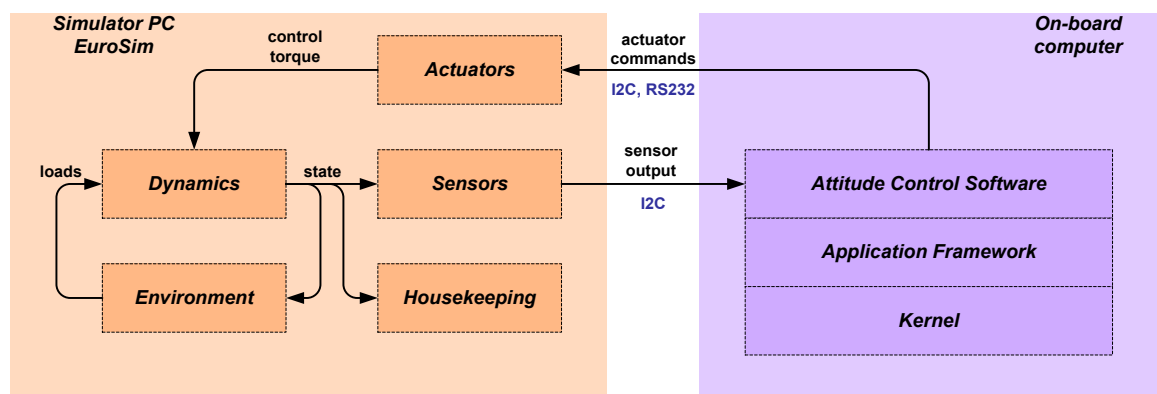

Figure 25 Test bench set-up

Finally, the actual interfaces will be implemented, both in EuroSim on the simulator PC and in the application framework on the on-board computer. Figure 25 shows the case for the closed-loop testing of the attitude control software, but the same set-up is applied to other parts of the on-board software (e.g. TM/TC manager).