



NLR-TP-2005-256

Optical air flow measurements for flight tests and flight testing optical flow meters

H.W. Jentink and R.K. Bogue*

* NASA, Dryden Flight Research Center

No part of this report may be reproduced and/or disclosed, in any form or by any means without the prior written permission of the owner.

This report may be cited on condition that full credit is given to NLR and the authors.

Customer: National Aerospace Laboratory NLR
Working Plan number: AS.1.F/AT.1.A
Owner: National Aerospace Laboratory NLR
Division: Aerospace Systems & Applications
Distribution: Unlimited
Classification title: Unclassified
May 2005

Approved by:

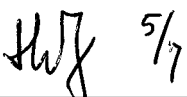
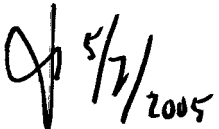
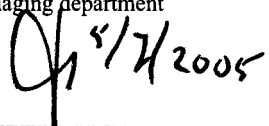
Author	Reviewer	Managing department
 5/7	 5/7/2005	 5/7/2005



Summary

Optical air flow measurements can support the testing of aircraft and can be instrumental to in-flight investigations of the atmosphere or atmospheric phenomena. Furthermore, optical air flow meters potentially contribute as avionics systems to flight safety and as air data systems. The qualification of these instruments for the flight environment is where we encounter the systems in flight testing. An overview is presented of different optical air flow measurement techniques applied in flight and what can be achieved with the techniques for flight test purposes is reviewed.

All in-flight optical airflow velocity measurements use light scattering. Light is scattered on both air molecules and aerosols entrained in the air. Basic principles of making optical measurements in flight, some basic optical concepts, electronic concepts, optoelectronic interfaces, and some atmospheric processes associated with natural aerosols are reviewed. Safety aspects in applying the technique are shortly addressed. The different applications of the technique are listed and some typical examples are presented.

Recently NASA acquired new data on mountain rotors, mountain induced turbulence, with the ACLAIM system. Rotor position was identified using the lidar system and the potentially hazardous air flow profile was monitored by the ACLAIM system.

NLR recently installed a laser anemometer in its Cessna Citation II research aircraft to evaluate its performance for detection of wake vortices. The development of the instrument and the evaluation for wake vortex detection was performed in a European co-operative research project I-Wake, supported by the European Commission. Partner organisations in I-Wake are Thales Avionics, Airbus, DLR, Université Catholique de Louvain, University of Hamburg, Fraunhofer Institut IOF, LISA Laser and NLR. The flight test capability for evaluating the laser anemometer is described and some results are presented.



Contents

Introduction	4
Optical air flow meters	4
Configurations of systems	6
Applications	8
Air data systems	8
Safety systems	9
Aerodynamic investigations	10
Atmospheric research	10
Parachute drop accuracy improvement	11
Recent developments	11
Nature of developments	11
NASA mountain rotor investigations	11
Higher power laser source development with communication-derived output frequency	13
Flight test plans for a molecular optical air data system	13
Flight testing the capabilities of a prototype lidar to detect wake vortices	14
Additional Planned Activities	17
Conclusions and final remarks	17
References	18

(20 pages in total)



Introduction

For flight testing new aircraft, the measurement of airspeed in three directions provides important data. Air data systems of fixed wing aircraft and helicopters can be calibrated with this data. Optical air flow meters are efficiently applied to gather the data. At much shorter range, velocity distributions in boundary layers can be measured. For in-flight research purposes optical air flow measurements contribute to the remote detection of atmospheric phenomena such as wind shears, mountain rotors, wake vortices and clear air turbulence. In avionics systems optical air flow measurements are developed for air data systems (airspeed, angle of attack and angle of sideslip) and as safety systems. The safety systems generate a warning when a wind shear, clear air turbulence or wake vortex is detected in front of the aircraft.

System configurations, basic operating principles of systems and applications are addressed in this paper. An AGARDograph was written by the authors on optical air flow measurements in flight that describes the history, principles and basic knowledge in more detail, ref. [1]. Recent advancements in optical air flow measurements made by NASA and NLR are presented.

Optical air flow meters

Optical airflow velocity meters use light scattering from in-homogeneities in the optical refractive index of air. The basic principles are utilized differently for the various anemometry systems and a vast number of anemometer types have been developed. The basic layout of an anemometer is a light source, a scattering medium, optical elements, a detector and signal processing electronics. The block diagram in Figure 1 illustrates how the system components are interconnected in a variety of airborne flow-measurement systems. Most systems contain all of the components shown, however, all of the connecting links may not be required for all systems.

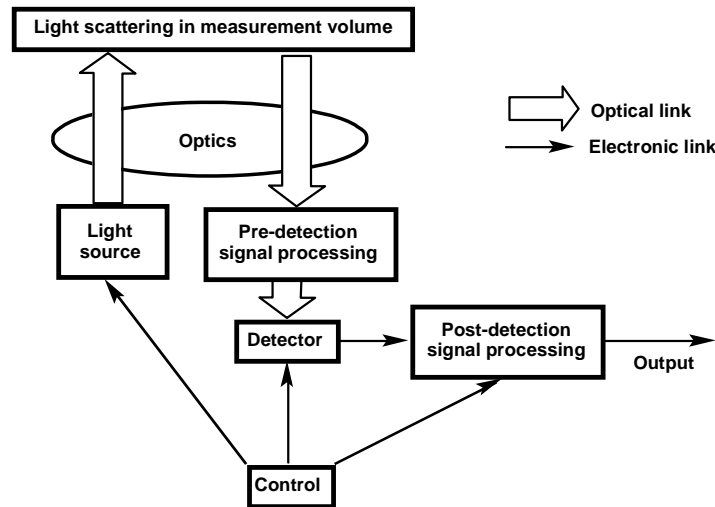

Figure 1: Generic block diagram of an in-flight flow measurement system.

Specific characteristics of components will be reviewed briefly followed by some words about the different configurations of systems.

Light source

Optical flow measurement systems use lasers as a light source. The laser emits a well-focussed light beam, the light is coherent and the efficiency of the electrical power to light conversion is high. Modern lasers are ruggedly build to sustain a vibrating environment and are compact for easy installation. In some systems the pulse option of lasers is utilized to limit the extent of the volume in which the velocity is measured. Optical components may also limit the extent of the so-called measurement volume, both by focussing the light beam in the measurement volume and by imaging only part of the illuminated measurement volume on the detector. The high light intensity generated by lasers leads to safety considerations and appropriate safety measures should be applied, for instance ANSI Z136.1 [2] in the USA.

Light scattering in measurement volume

Most optical flow meters utilize the scattering of light on aerosols. Air molecules can also provide the scattering needed, but the scattered light power obtained from molecular scattering is very low. Scattering at shorter wavelength light presents large challenges to overcome [3], [4]. The presence of air molecules is guaranteed for atmospheric flights, which is an advantage over the use of aerosols for scattering. The concentration of aerosols in the atmosphere in general decreases with altitude. This means that low backscatter levels due to low aerosol concentration should be considered. In general, for the commonly applied reference beam anemometer the signal below 25,000 feet altitude tends to be not too much of a limitation of the technique especially for flight test applications where interruptions in signals may be allowed.



Compared to molecular backscatter, light scattered from aerosols has a more sharply defined signature that is often used to reduce measurement uncertainty in molecular scattered returns.

Pre-detection signal processing

In the optical domain the scattered light can be processed before the light signal is converted into an electrical system. An example is inserting an optical filter in the light beam. More advanced processing utilizes the coherent character of light to transfer a high frequency optical signal into a much lower (e.g. Doppler shift) frequency. This coherent detection feature is one of the advantages made possible by the use of coherent laser light.

Detector

The optical signal is transferred in the optical domain to a detector. Detector efficiencies are dependent on optical wavelength range of light. For each laser wavelength an efficient detector can be chosen, where the use of semiconductor materials leads to compact detectors.

Post-detection signal processing

Fourier transformation of signals or measuring time between scattering events are common treatments of signals to derive velocity information.

Control

Especially when pulsed lasers or gated detection is applied the coordination of the process timing is essential. So called range gating uses the time between the transmitted pulse and the received backscatter to control the range from which atmospheric measurements are obtained.

Configurations of systems

The optical air flow meter applied most frequently in flight is the reference beam anemometer. To extract velocity information, the Doppler shift of the frequency of light from the scattering of light in the measurement volume is measured. The very small frequency shift compared with the light frequency is measured by mixing the scattered light with light in a reference beam with the original light frequency (see Figure 2). This coherent detection technique results in an electrical signal on the detector with the difference frequency of the scattered light and reference beam light, which is equal to the Doppler frequency

$$\delta f = 2 f v_{\text{los}} / c$$

where f is the frequency of light, v_{los} is the velocity component in the direction of the light beam and c is the velocity of light. Characteristics of the reference beam anemometer that are well suited to the in-flight application are:

- velocities can be measured at large distances from the anemometer (several kilometres)
- due to a large measurement volume and efficient scattered light collection, low densities of scattering particles are sufficient for adequate measurements. Densities found up to 25,000 feet altitude are commonly sufficient.

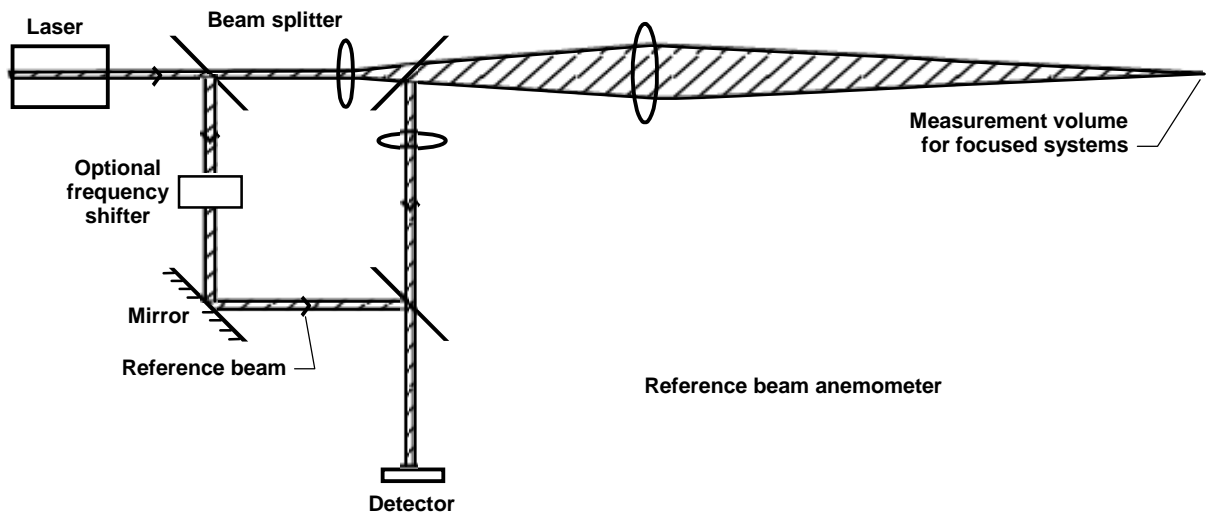

Figure 2: The reference beam in backscatter configuration.

The dual beam laser Doppler anemometer or fringe anemometer measures velocities

- in a small well defined measurement volume
- at a limited distance from the anemometer.

This anemometer is much more frequently used in ground-based applications than the reference beam anemometer. In a dual-beam laser Doppler anemometer two coherent light beams are crossed to create a measurement volume at the beam intersection (see Figure 3). Individual particles traversing through the measurement volume scatter light from both beams. A detector measures the intensity fluctuations of scattered light, the frequency of which is a constant, times the velocity component of the scatterer in the intersecting beam plane, perpendicular to the bisector of the beam propagation vectors. The frequency of intensity fluctuations is independent of the detection angle.

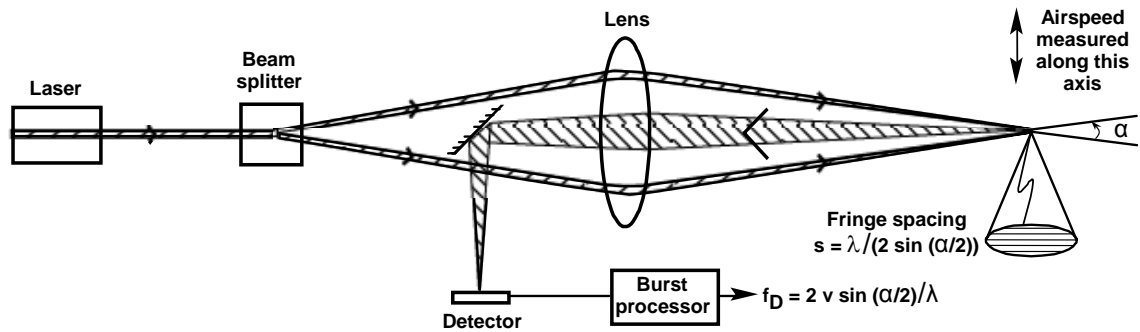

Figure 3: Dual-beam laser Doppler configuration.

A fringe model is widely in use to explain the principle of the dual-beam laser Doppler anemometer. The model considers an interference pattern formed by the two beams in the measurement volume. The interference pattern has parallel light and dark planes, called “fringes”, in the measurement volume as shown in Figure 3. The frequency fluctuation that results on the detector when a particle passes the interference pattern is

$$f_D = 2 v \sin(\alpha/2) / \lambda$$

where v is the particle velocity component in the plane of the two intersecting beams, perpendicular to the bisector of the beam directions, α is the intersection angle of the two light beams and λ is the wavelength of the light.

Applications

Optical air flow meters are applied in flight for different purposes. This section presents an overview of the different applications of laser anemometry in aircraft. The character of applications differs considerably. Anemometers are applied for basic research, for industrial flight testing new aircraft and in avionic systems. Flight test engineers are involved in all these applications where the nature of involvement differs considerably depending on measurement requirements.

Air data systems

The airspeed of aircraft can be measured with laser anemometry [5], [6], [7]. The angle of attack and the angle of sideslip can also be derived through the three-component application of laser anemometry. When the measurement volume of the laser anemometer is located outside the local flow field of the aircraft, air speed can be measured without having to calibrate for installation errors. Measurements closer to the aircraft can also be used by applying calibration factors to the sensor outputs, as is common practice for conventional air data systems.

Optical air data systems have potential applications especially in fighter aircraft, stealth aircraft, and helicopters. In fighter aircraft the high-angle-of-attack manoeuvres and the high dynamics put severe requirements on the performance of air data systems. For stealth aircraft, the optical systems remove the need for protruding pitot tubes, thereby preserving the low radar cross-section characteristics. Optical techniques also have advantages for the measurement of helicopter airspeed. Conventional air data sensors are installed on helicopters in the flow field generated by the rotor, which requires substantial flow corrections, especially at low speeds. Optical measurements [8] made outside the influence of the rotor wash do not require flow corrections.

Laser anemometers are also used for calibrating air data systems in flight. The errors in the conventional system (position error, compressibility influence, and aircraft attitude effects, etc.) can be determined by measuring air data simultaneously with a conventional air data system and with a laser anemometer. Laser anemometers have been operated in prototype aircraft for this purpose since 1991 [9], [10], [11]. Figure 4 shows the three directions in which line-of-sight velocities are measured. Operating the anemometers in prototype aircraft from the first flight on provides accurate air data from the very beginning, which is helpful, for example, in expanding flight envelopes.

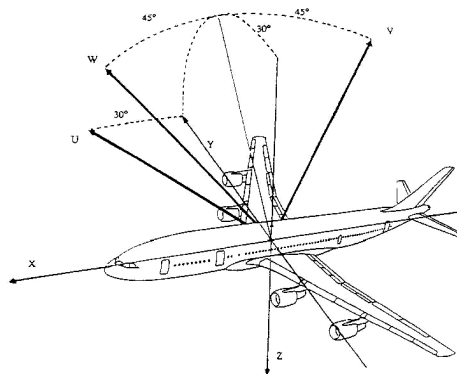

Figure 4: Line-of-sight measurement in three directions to derive true airspeed, angle of attack and angle of sideslip for calibrating the air data system.

Safety systems

In the pursuit of making aviation safer, unexpected atmospheric flow phenomena pose a considerable challenge. One of the options to make aviation safer in this respect is to install advanced remote detection systems for these phenomena. Laser anemometry for hazard detection is under development. Important requirements on the advanced detection system are remote detection at a considerable distance (so that adequate action, such as fastening seat belts or avoidance manoeuvres can be taken to avoid entering a hazardous air mass) and the ability to operate (complementary to radar) in clean air. Both requirements seem feasible for laser anemometry.



Systems have been studied to detect the following phenomena.

- Wind shears - During landing or takeoff, abrupt changes of wind speed experienced by aircraft are particularly dangerous. Downbursts of air can cause rapid reductions in headwind thereby causing rapid changes in descent rate and risking impact with the ground [5], [12], [13].
- Clear air turbulence - Clear air turbulence provides no visual cues of its presence and is often encountered during the cruise phase of a flight. The turbulence causes many injuries, especially among flight attendants.

Another need for detecting clear air turbulence may appear if new fuel-efficient supersonic aircraft are designed [14]. Turbulence may cause engine unstarts that pose an unacceptable safety risk and reduce passenger comfort dramatically.

- Wake vortex - Every aircraft in the air generates wake vortices, posing a potential danger for an aircraft in trail flying through these hazardous conditions. Air traffic control at airports takes this potential danger into consideration in determining the safe distance between landing aircraft. A detection system close to the runway or onboard the aircraft can support the determination of safe distances as a function of atmospheric conditions (such as wind) and aircraft type. Many studies are in progress on this subject [15], [16], [17], [18]. The feasibility of wake vortex detection from the at-risk aircraft has been demonstrated using laser anemometry technology.

The development of systems to detect the safety hazards listed above and also the potential threats of volcanic ash and ice crystals is in progress [18], [19]. The detection of all these hazards in one system is an extra challenge, but makes the system much more profitable for commercial aviation applications.

Aerodynamic investigations

Measuring airflow very close to the aircraft gives information relevant for aerodynamic research. In-flight feasibility of this kind of measurement was demonstrated in [20], [21], [22]. Investigations of, for instance, the vortices generated by the aircraft [23], the flow behind propellers, laminar-to-turbulent flow transition [20] and flow in the wing-body junction may benefit from applying laser anemometry.

Atmospheric research

Aircraft have been used as platforms to carry laser anemometers investigating atmospheric phenomena [24], [25], [26], [27], [28]. Thunderstorm investigations, wind shear characterizations and particle density measurements have been reasons for flight campaigns. A considerable number of air masses can be reached in a short period of time in flight campaigns



and the remote character of this technique is valuable if potentially hazardous atmospheric conditions such as thunderstorms and wind shear are to be investigated.

Parachute drop accuracy improvement

In situations where small arms fire may threaten the delivery aircraft, it is necessary to drop parachutes from considerable altitudes. The drop accuracy from these altitudes is reduced because of wind uncertainties. Development of laser anemometry technology for measurement of the wind field below the drop aircraft was initiated to adjust the cargo release point for wind drift compensation [29].

Similarly for ballistic munitions, the influence of wind on the trajectory can be determined with laser anemometry. By correcting for these influences the first-round accuracy can also be improved [29].

Recent developments

Nature of developments

Flight testing of optical flow measurements in new situations provides new insight into performance capabilities and validates the use of optical techniques in new environments. Advances in optical technology provide incremental improvements in system performance and offer the potential of increasing data quality (i.e. less uncertainty, higher measurement rate) and in the case of lasers with increased power, bring the capability for making measurements at longer range. For many years, it has been expected that the demand for optical technology from the communication industry would provide system components that could be used in optical flow measurement applications. This technology development is beginning to increase and optical measurement systems are being constructed around 1.5μ wavelength components thereby allowing reduced system costs by using production communication system components.

NASA mountain rotor investigations

In the spring of 2003, the NASA DC-8 aircraft as a part of testing of the ACLAIM turbulence lidar system, conducted testing in mountain rotor conditions to assess the effectiveness of lidar measurements for remotely detecting turbulence [30]. Figure 5 shows the NASA DC-8 aircraft with a simulated red beam indicating the position of the lidar laser beam on the aircraft. Figure 6 shows the turning mirror installation in the stowed position on the DC-8 aircraft. During flight operations with the lidar, the turning mirror faring is rotated so that the flat surface is facing forward to project the beam in the desired direction.



Figure 5: NASA DC-8 Aircraft showing the position of the Lidar installation [30].



Figure 6: Lidar turning mirror faring in stowed position on the NASA DC-8 aircraft [30].

Mountain rotor conditions are indicated on weather maps that show banding of moisture concentrations. Figure 7 shows a moisture concentration map of the California region with bands of moisture in the vicinity of the California-Nevada border which is the area where the mountain rotor conditions were encountered. Rotor conditions had not been previously encountered during prior flight testing and the performance of the lidar in this situation was needed to round-out the set of atmospheric conditions where turbulence often occurs and remote turbulence detection will be needed to provide warning for safety purposes. Figure 8 illustrates the agreement between lidar-based airspeed measurements and the aircraft airspeed measurements in the mountain rotor region. Results from this testing confirmed that with the ACLAIM system (operating at the 2 μ wavelength with a pulse energy of 8 milli-Joules) turbulence could be reliably detected at a range of 2 km. Under special conditions, detection was possible out to 6 km. Severe turbulence was encountered during the flight deployment (+/- 1.3 g). The flight activity confirmed that there were no issues with detecting turbulence at these levels using the reference beam lidar configuration.

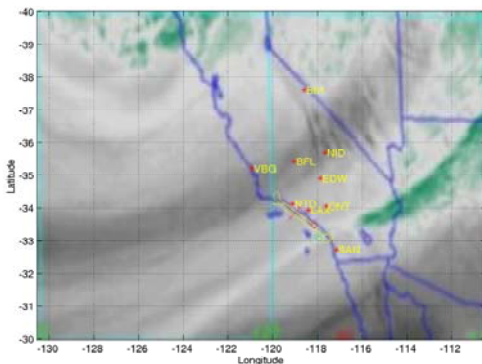

Figure 7: Weather map showing bands of moisture concentrations on the California-Nevada border indicating mountain rotor conditions [30].

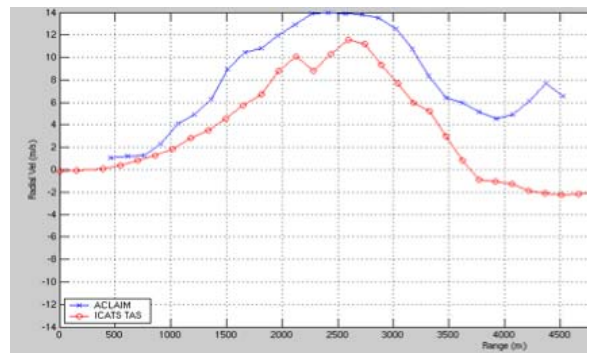

Figure 8: Chart showing lidar airspeed (blue) and conventional airspeed comparison in the mountain rotor region [30].



Significance of Activity: This activity demonstrated the capability of the reference-beam lidar system to remotely measure turbulence hazards under mountain wave conditions (varying moisture levels and turbulent air. It also confirmed the range vs. power relationship observed on prior flight tests.

Higher power laser source development with communication-derived output frequency

At Coherent Technologies Inc. (CTI) [31] a pulsed laser source with increased power has been developed that operates at a 1.5 μ wavelength with an output pulse energy of ~200 milli-Joules and a pulse-repetition rate of 20 Hz. This system used Raman technology and offers improved efficiencies. With minimal optimization of the system, operation at a range of 7 km is predicted with further range improvements as design optimization is increased.

Significance of Activity: The impact of this increased power on the flight optical flow measurement capability is to provide increased sensing range through the increased power. All else being equal, the range of a lidar system is proportional to the square of the pulse energy. During the mountain rotor flight testing, the lidar was able to provide measurements at 2 km. with a pulse energy of 8 mJ. With a pulse energy of 200 mJ, the range could be extended to 10 km, a value much more in line with turbulence warning requirements of commercial airliners.

As previously indicated, migration to the 1.5 μ operating wavelength presents the capability to use communication-based system components to reduce costs and also provide a wider variety of components for design flexibility.

Flight test plans for a molecular optical air data system

At Michigan Aerospace Corporation, [32] preparations are underway to flight test the Molecular Optical Air Data System (MOADS) on a Beechcraft King Air at altitudes up to 25k feet. The MOADS is designed to acquire airspeed in 3 dimensions and in addition measure air density and temperature to provide the complete suite of air data measurements from a single device. This activity is the first attempt to flight test a reference beam anemometer using Doppler-shifted molecular backscatter to provide airspeed measurements. The use of backscatter from molecules, which are far more plentiful and more predictable than aerosols improves the reliability of system operation. It is necessary to use a shorter operating wavelength in the ultra-violet band to provide enhanced scattering from molecules. Coherent detection at the UV wavelengths is impractical and direct detection of the Doppler shift is obtained from high finesse etalon filters. The system is installed in a side window of the King Air as shown in Figure 9. Airspeed components are measured along the axes of the three laser beams projected from the MOADS optical head as shown in Figure 10.



Figure 9: Beechcraft King-air showing MOADS laser beams projected from a side fuselage window [32].

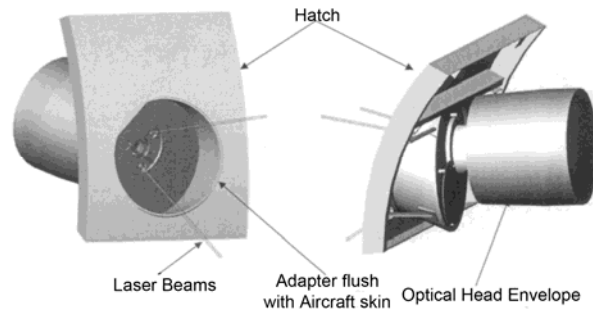

Figure 10: MOADS Optical Head showing three laser beams projected into the measurement region to the side of the aircraft [32].

A key factor in the operation of the MOADS is a high finesse etalon filter that provides a stable and sharp frequency/amplitude characteristic that converts Doppler shifted backscattered light into a change in amplitude. This amplitude variation can be converted into an estimate of Doppler shift and hence a corresponding estimate of the Doppler shift and thereby of the airspeed.

Significance of Activity: This is the first flight test of an air data system based on molecular backscatter to acquire the air density in addition to the vector airspeed. Results from this test will provide major insight to the potential of this approach for future air data applications.

Flight testing the capabilities of a prototype lidar to detect wake vortices

In the I-Wake project, an optical system is developed for the detection of atmospheric hazards, including wake vortices, clear air turbulence, windshear and volcanic ash. The development is performed in a European co-operative research project, supported by the European Commission. Partner organisations in I-Wake are Thales Avionics, Airbus, DLR, Université Catholique de Louvain, University of Hamburg, Fraunhofer Institut IOF, LISA Laser and NLR.

In the summer of 2004 a prototype instrument was flight tested. The instrument was installed in NLR's Cessna Citation II research aircraft while the Citation followed an Airbus A340-600 prototype. The Citation positions were chosen such that the measurement volume of the I-Wake anemometer scanned through the A340 wake vortices at different distances. Wake vortices were measured during the flight and algorithms are being optimized for rapid and reliable identification of wake vortices. As an indication of results Figure 11 shows the results of multiple scanning planes recorded while the instrument is on the ground, in line with the runway of Blagnac Airport in Toulouse, France.

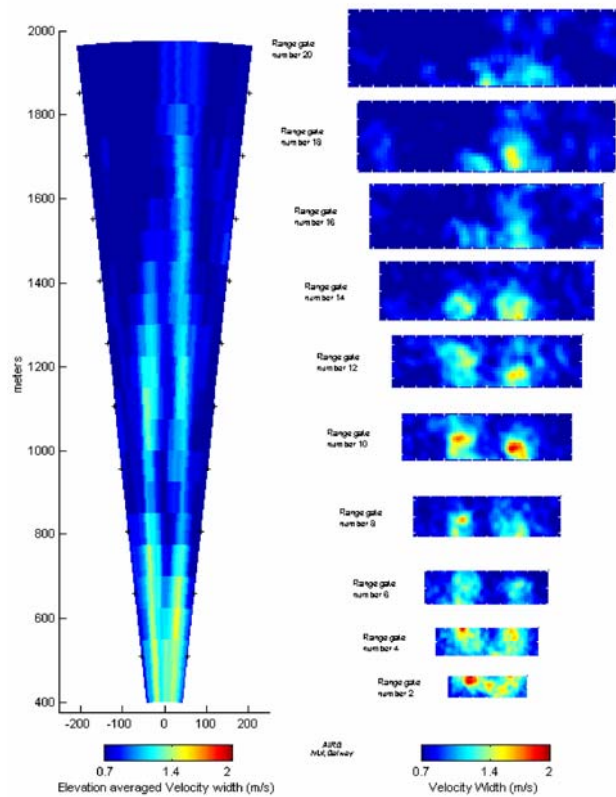

Figure 11: Wake vortices detected with I-Wake / MFLAME detection system.

An aircraft modification was required, in order to equip the Citation with a fairing to protect the scanner from the airflow around the aircraft. Having the scanner partly outside of the cabin was necessary, as the laser beam should be able to scan through a measurement volume in front of the aircraft. A cabin window was therefore removed from the aircraft giving access for the scanner and the infrared light beam. Figure 12-3 shows the optical fairing with the integrated quartz glass window. The I-Wake instrument scans the volume from 800 m to 2400 m with a horizontal scan angle from 3 to 15 deg to the right and with a vertical scan angle from 7.5 to 10.5 deg down. These angles are with respect to the aircraft body axis. The I-Wake system effectively produces scans in 19 planes in front of the aircraft. In each plane approx. 2400 air flow measurements are gathered. The resolution in the direction of the light beam, defining the 19 planes, is obtained by monitoring the time between emitting a laser pulse and receiving scattered light (time gating). The optical system includes a water-cooled solid-state laser emitting light at around 2 μm and advanced mirror control for scanning the measurement volume. Furthermore, control, signal processing and storage electronics including displays are installed in the cabin, which fills the aircraft cabin for a considerable part. As once was for compact disc players, the potential is there to develop compact and cheap systems.



The instrumented tests consisted of runway performance tests (with and without rotation – but no lift off), followed by actual test flights. During the tests, tufts (i.e. small threads taped to the aircraft skin panels – see Figure 12-2) were used to visualise the airflow. Onboard camera's recorded the behaviour of the tufts. NLR's Swearingen Metro II research aircraft – which was flying in close formation – also made video- and photo shots. An aerodynamic expert closely observed the airflow behaviour from within the Metro. Both in-flight and post-flight evaluations did not reveal anomalies compared to normal operations without fairing.



Figure 12-1: Photo of the Citation in flight.



Figure 12-3 Fairing on the NLR Cessna Citation II housing the mirror deflecting the I-Wake laser beam to the measurement volume in front of the aircraft and receiving scattered light. On the two pictures on the left side tufts are attached to the fairing and aircraft to study the influence on aerodynamics. In the picture above the final coating has been applied



Figure 12-2: Photo of the tufts showing the air flow behind the fairing on the Citation.

Significance of Activity: The flight test confirmed that the I-Wake wake vortex detecting system was able to successfully detect hazards using a fairing and window through which the laser beams and backscattered energy were propagated. It also confirmed that the addition of the fairing did not cause serious change in aircraft performance or pose significant safety hazards.



Additional Planned Activities

Further utility of the capability to make optical flow measurements in flight is planned. The valued capability provided by these optical techniques continues to be in demand as indicated by the continued development and testing campaigns. The following table summarizes the known planned activities to develop or commercialize optical flow measurement techniques:

Optical Flight Flow Measurement Development and Commercialization Activities				
Name	Company	Goal	Schedule	Notes
Molecular Air Data Flight Test	Ophir Corporation, Littleton, Colorado	To demonstrate the performance of a Molecular Air Data System in flight	Fall 2006	System uses molecular filters for direct detection Testbed will be a light aircraft
Airborne Windshear Detection	Swan International Services Pty Ltd, Sydney, Australia	To develop a commercial airborne windshear detector for use on classes of aircraft from private through small business & transport	Unknown	System uses pulsed near IR laser operating at 1.55 μ

Conclusions and final remarks

Optical air flow measurements are applied for flight test purposes, but to a limited extent. Development of systems as avionic parts of the aircraft resulted in promising prototypes. It is expected that development of the optical components will enhance the capabilities of optical air flow measurement systems considerably in the near future. For instance the availability of new compact, powerful and low-cost solid state lasers is expected to reduce the size and cost of systems considerably. The flight test engineer will benefit in having additional tools for measuring fundamental parameters for flight characterisation. Furthermore the tests of avionic systems and the atmospheric research will provide new interesting challenges.

References

- [1] Bogue, R. K.; H.W. Jentink; "Optical Air Flow Measurements in Flight", RTO AGARDograph 160, Flight Test Instrumentation Series, Vol. 20 / SCI-033 (2002)
- [2] ANSI Z136.1 - 2000 "Safe use of Lasers in an Outdoor Environment", published by the American National Standards Institute, Washington, D.C. and New York, N.Y. (2000)
- [3] Rees, D.; I.S. McDermid; "Doppler lidar atmospheric wind sensor: re-evaluation of a 355-nm incoherent Doppler lidar", Appl. Opt. 29 (1990) p. 4133
- [4] Skinner, W.R. ;P.B. Hays; "Incoherent Doppler lidar for measurement of atmospheric winds", SPIE vol. 2266 "Optical spectroscopic techniques and instrumentation for atmospheric and space research", p. 383 (1994)
- [5] Woodfield, A.A.; J.M. Vaughan; "Airspeed and wind shear measurements with an airborne CO₂ cw laser", AGARDograph-AG-272 "Advances in sensors and their integration into aircraft guidance and control systems", p. 7 (1983)
- [6] Smart, A.E.; "Optical velocity sensor for air data applications", Opt. Eng. 31, p. 166 (1992)
- [7] McGann, R. L.; "Flight test results from a low-power Doppler optical air data sensor", Proc. Air traffic control technologies, SPIE vol. 2464, p.116, Orlando, FL, USA, 18-19 April 1995
- [8] Mandle, J.; F.X. Weiss; "New calibration methods in air data measurement for low-speed helicopters", AGARD CP 359, p. 16, Monterey, CA, USA, 8-11 May 1984
- [9] Mandle, J. ;E. Fabacher; "Laser anemometry for flight test", Proceedings ETTC '91, 25-26 June 1991, Toulouse, France, p. 3-4
- [10] Cattin-Valsecchi,F.; C. Lopez; "Utilisation d'un velocimetre laser triaxe pour calibration anemometrique sur AIRBUS A340", AGARD-FMP-Symposium, Chania, Greece, p. 26 (1992)
- [11] Alonso,F.; "Anemometric calibration test methods for Airbus A 330/340", Proceedings ETTC 91, 25-26 June 1991, Toulouse, France, p. 2-7
- [12] Köpp, F.; "Airborne CO₂ Doppler lidar for wind shear detection", in DLR Mitt. 90-04 "Aircraft integrated monitoring systems", p. 481 (1990)
- [13] Targ, R.; M.J. Kavaya; R.M. Huffaker; R.L. Bowles; "Coherent lidar airborne windshear sensor: performance evaluation", Appl. Opt. 30, p. 2013 (1991)
- [14] Bogue, R.K.; H.R. Bagley; D.C. Soreide; "Coherent lidar solution for the HSCT supersonic inlet unstart problem", in Air traffic control technologies, SPIE Proc. 2464 (March 1995) p. 94
- [15] Hannon, S.M.; J.A. Thomson; Aircraft wake vortex detection and measurement with pulsed solid-state coherent laser radar, J. of Modern Optics, Vol. 41 (1994) p. 2175



-
- [16] Keane, M.; M. Redfern; "Airborne Wind Shear Detection with the MFLAME 2 μm Lidar", Proc. 9th Conf. on Coherent Laser Radar, June 23-27, 1997, Linköping, Sweden, p 126 (1997)
- [17] Keane, M.; D. Buckton; M. Redfern; C. Bollig; C. Wedekind; F. Köpp; and F. Berni; "Axial detection of aircraft wake vortices using Doppler lidar", J. Aircraft 39, p. 850-862 (2002)
- [18] Combe, H.; F. Köpp; M. Keane; "MFLAME, Definitions, ground experimentation and results in the MFLAME EC Programme", 3rd Wakenet workshop, Great Malvern, UK, 22-23 May 2000
- [19] Köpp, F.; G. Powilleit; "Investigation of the 3d wake-vortex velocity field for the development of airborne detection systems", Proc. 9th Conf. on Coherent Laser Radar, Linköping, Sweden, June 23-27, 1997, p. 317
- [20] Becker, S.; F. Durst; H. Lienhart; "Laser Doppler anemometer for in-flight velocity measurements on airplane wings", AIAA Journal 37, p. 680 (1999)
- [21] Jentink, H.W.; M. Stieglmeier; C. Tropea; "In-flight measurements using laser Doppler anemometry", J. of Aircraft vol. 31, p. 444 (1994)
- [22] Jentink, H.W.; M. Beversdorff; W. Förster; "Laser anemometry for in-flight investigations", Proceedings 5th IEEE-ICIASF Conference, Dayton, Ohio, USA, 18-21 July 1995, p. 23
- [23] Meyers, J.F.; "Development of Doppler Global Velocimetry as a flow diagnostics tool", Measurement Science and Technology vol.6, p. 769 (1995)
- [24] McCaul, E. W.; H.B. Bluestein; R.J Doviak; "Airborne Doppler lidar techniques for observing severe thunderstorms", Applied Optics vol. 25, p. 698 (1986)
- [25] Werner, Ch.; P. Flamant; O. Reitebuch; F. Köpp; J. Streicher; S. Rahm; E. Nagel; M. Klier; H. Herrmann; C. Loth; P. Delville; Ph. Drobinski; B. Romand; Ch. Boitel; D. Oh; M. Lopez; M. Meissonnier; D. Bruneau; A. Dabas; "Wind infrared Doppler lidar instrument", Opt. Eng. 40, 115-125 (2001)
- [26] Reitebuch, O.; Ch. Werner; I. Leike; P. Delville; P. Flamant; A. Cress; D. Engelbart; "Experimental validation of wind profiling performed by the airborne 10- μm heterodyne Doppler lidar WIND", J. Atmos. Oceanic Technol. 18, 1331-1344 (2001)
- [27] Rahm, S.; "Precursor experiment for an active airspeed sensor", Optics Letters, 26, 319-321 (2001)
- [28] Reitebuch, O.; H. Volkert; Ch. Werner; A. Dabas; P. Delville; Ph. Drobinski; P.H. Flamant; E. Richard; "Determination of air flow across the Alpine ridge by a combination of airborne Doppler lidar, routine radio-sounding and numerical simulation", Q. J. R. Meteorol. Soc. 129, p. 715-728 (2003)



- [29] Richmond, R.; D. Jewell; J. Carr; J. Root; "U.S. Air Force ballistic winds program", SPIE Proc. 3065 "Laser Radar Technology and Applications II", 21-25 April 1997, Orlando, FL, p. 2 (1997)
- [30] Teets, E.; C. Ashburn; "Turbulence and Mountain Waves Observed with an Airborne 2-Micron Doppler lidar", 11th Conference on Aviation, Range and Aerospace Meteorology, 5 October 2004, Hyannis, MA
- [31] Monarski, T; S. Hannon; P. Gatt, "Eye safe coherent lidar detection using a 1.5 μ Raman laser", Laser Radar Technology and applications VI, Gary W. Kammerman, Editor, Proceedings of Society of Photo-optical Engineers Vol. 4377 (2001)
- [32] Watkins, C.; C. Richey; P. Tchoryk; G. Ritter; et al, "Molecular optical air data system (MOADS) Flight Experiment", Society of Photo-optical Engineers Aerosense 2003 Symposium, 24 April, 2003, Orlando, FL